

55546 Yucca Trail,
Yucca Valley, CA 92284
APN: 059-404-122
Drainage Study

Submitted to:

Town of Yucca Valley
Public Works
57090 Twentynine Palms Highway
Yucca Valley, CA 92284

Prepared by:

DRP Enterprises LLC
PO Box 4428
Palm Springs, CA 92263



Prepared: May 26, 2025
Revised: August 14, 2025

Prepared by

DRP Enterprises LLC
PO Box 4428
Palm Springs, CA 92263

Table of Contents

1	PURPOSE AND SCOPE _____	1
2	HYDROLOGY METHODOLOGY _____	1
3	ONSITE HYDROLOGY _____	2
4	INPUT PARAMETERS _____	2-3
5	CALCULATIONS _____	4-5
6	DISCUSSION OF ONSITE HYDROLOGY _____	5
7	DISCUSSION OF OFFSITE WASH AND 100-YR FLOODPLAIN _____	5-6

EXHIBITS:

EXISTING CONDITION HYDROLOGY SHED MAP

PROPOSED CONDITION HYDROLOGY SHED MAP

**REFERENCE MATERIALS FOR SOIL MAP, TIME OF CONCENTRATION, RAINFALL INTENSITY,
WASH ANALYSIS**

HEC-RAS RESULTS

DWR AWARENESS MAP

PURPOSE AND SCOPE

The 55546 Yucca Trail commercial project is a 5.75+/- acre lot with the APN: 059-404-122 owned by Evoque modern is located in the Town of Yucca Valley, California. It is bounded by Yucca Trail on the south, existing developments on the west & east, vacant lots on the north.

The subject site is currently undeveloped and has a gradual slope (approximately, 3 to 4 percent slopes) gradient from northeasterly to the southwesterly side. The site drains by sheet flow to the southwesterly side and is subject to offsite flows.

Washes from sawtooths, north park peak, water canyon, little-long canyon that make their way from southwesterly to northeasterly around the project site and per FEMA Flood Map The project site is located in FEMA 'Zone A' and also in DWR Awareness area for 100-Yr storm event.

The proposed development includes new warehouse buildings, driveways, storm drain, sewer, water, landscaping, walkways etc. will be built. The site will be designed to retain the existing drainage pattern. This study will determine the 100-year offsite storm flows and also the increased runoff from the projected development.

HYDROLOGY METHODOLOGY

The onsite watershed affected by the development was analyzed by the Rational Method described in the '**Town of Yucca Valley Hydrologic Studies**' and '**Town of Yucca Valley Hydraulic Design Criteria and Facility Sizing**' to study 100-year storm event. The rational method formula is expressed as:

$Q = CIA$; Where, Q = Peak discharge, in cubic feet per second (cfs)
C = Runoff Coefficient, portion of rainfall that runs off the surface (no units)
I = Average Rainfall Intensity (in inches/hour) for a duration equal to the T_c for the area
(Note: If the computed T_c is less than 5 minutes, use 5 minutes for the peak discharge, Q)
A = Area of Lot in acre

The offsite wash coming from the upstream of the project site was analyzed by the **Town of Yucca Valley Hydrologic Studies Unit Hydrograph Method** and **HEC-RAS** were utilized to model the hydraulics of offsite washes.

Intensity-duration data was obtained from the NOAA Precipitation Frequency Data Server (PFDS) Rainfall Intensity data.

The soil type was obtained from the Hydrology Manual. The predominant soil type obtained from the Manual was determined to be moderate infiltration and moderate-class runoff (type B) for the project site.

Both existing and ultimate conditions were analyzed. For the existing condition, undeveloped land use was assumed to model current storm discharges and for the proposed condition, building type development condition used.

WATERSHED BOUNDARIES

The site is currently undeveloped, has a gradual slope of approximately 2-3% and it drains by sheet flow from northeasterly to the southwesterly side. For the 100-yr peak flow hydrologic analysis, the existing site is assumed as a single drainage area **DMA-X** (5.75-acre) (**Exhibit-A**). 100-Yr existing condition peak flow rate shall be based on 100-Yr 24-Hr storm using AMC II' Per 'Town of Yucca Valley Hydrologic Studies'.

The proposed development associated with site improvements include grading and drainage, sewer, water, landscaping, driveway, pavement, trash enclosure. For the proposed condition the subject site is also assumed as a single drainage area **DMA-A** (5.75-acre) drains to the southwesterly at the same corner with a slope of about 1-2% (**Exhibit-B**). The lot will be graded to surface flow through the site utilizing swale and slopes to convey flow through **storm drain systems** into the proposed infiltration basin on the southwesterly corner of the property.

On the upstream of the project site there are washes named **WASH-Y** that make its way from southwesterly to northeasterly. The **WASH-Y** watershed is about 6,500 acres.

INPUT PARAMETERS

The following values were used in calculating the 100-year storm flow for existing and proposed conditions. The SBC Hydrology Manual was used to determine these hydrological parameters. The area distribution for the project site and time of concentrations for corresponding watersheds are as following:

Drainage Area	Area (AC)	Flow Path (ft)	Elevation Diff (ft)	Time of Conct. (min)
DMA-X (Existing Cond)	5.75	770	25	15
DMA-A (Proposed Cond)	5.75	660	15	8

Time of Concentration, minutes: Time of concentration (Tc) calculations were performed using Nomograph for Determination of Time of Concentration (Tc) or Travel Time (Tt) for Natural Watersheds (**Exhibit G**).

Soil Group: Hydrology Manual was used to determine soil types. Based on Hydrology Manual (**Exhibit-F**), the project site is classified as 'soil type B'.

Cover Type	Soil 'B' RI Value	Infiltration Rate, F _p
Existing Cond	57	0.73
Proposed Cond	74	0.48

The cover type was determined based on **Exhibit-H** for the existing land cover and proposed land use of the site. Hydrological computations for the existing site condition were assumed as 'Barren Natural Cover', for the proposed the site condition were assumed as 'Rural Residential'.

Rainfall Intensity, in/hr: The following rainfall depths were utilized in the hydrology analyses. The rainfall values were obtained from the NOAA Precipitation Frequency Data Server (PFDS) (**Exhibit-J**).

Storm Event	Rainfall Depth (in)
100-Year 1 hour	1.88

The value for Log-Log slope for sub-hourly rainfall intensity is 0.7 for desert areas. The rainfall intensities were obtained from the SBC Hydrology Manual based on Figure D-3 (**Exhibit-K**). The isohyetal maps from the Hydrology manual have also been included.

Drainage Area	Time of Conct. (min)	Slope of Intensity (desert Area)	Rainfall Intensity (in/hr)
DMA-X (Existing Cond)	15	0.7	5.0
DMA-A (Proposed Cond)	8	0.7	7.8

Actual Impervious Cover, %: The actual impervious cover were obtained from the SBC Hydrology Manual based on Figure C-4 (**Exhibit-H**):

Type of Project	Impervious Cover (in)
Commercial	90%

Peak Flow, cfs: The value for the peak flow was determined once Rainfall Data and Runoff Coefficient values were calculated using the parameters.

Drainage Area	Area (AC)	Runoff Index Values	F _p	a _i (% Imperv)	a _p (% Perv)	Rainfall Intensity, I (in/hr)	Peak Flow, Q (cfs)
DMA-X (Existing Cond)	5.75	57	0.73	0	1	5.0	22.1
DMA-A (Proposed Cond)	5.75	74	0.48	0.9	0.1	7.8	40.12

The Calculations can be seen in detail in the following Section.

CALCULATIONS

$Q=CIA$; Where, C = Runoff Coefficient

$$C = \begin{cases} 0.90 \left(a_i + \frac{(I - F_p)a_p}{I} \right), & \text{for } I \text{ greater than } F_p; \\ 0.90 a_i, & \text{for } I \text{ less than or equal to } F_p \end{cases}$$

Onsite Peak Flow (Existing Condition) (DMA-X)

For Existing Condition, Runoff Index = 57, AMC-II, $F_p = 0.73$ in/hr (**Exhibit-I**)

Time of concentration can be determined from Exhibit-G using the following parameters:

ΔE = Elevation difference between the longest flow path upper and lower most points = 25 feet

L = Flow path Length = 770 feet

Time of concentration ' t_c ' is found 15 minutes.

Rainfall intensity can be determined from Exhibit-L using the following parameters:

t_c = Time of concentration = 15 minutes

Slope, $S=0.7$ (for desert areas per SB County Hydrology Manual 'Section B.8')

100-Yr 1-hour Precipitation depth = 1.88 inch (**Exhibit-J**)

So, 100-Yr Rainfall intensity for 15 min storm, $I = 5.0$ in/hr (**Exhibit-L**)

So, DMA-X 100-Year peak flow, $Q = C \times I \times A = 0.90(a_i + ((I-F_p)a_p)/I) \times I \times A$

$$Q = 0.90 \times (0 + ((5.0-0.73) \times 1)/5.0) \times 5.0 \times 5.75 = 22.1 \text{ cfs}$$

Onsite Peak Flow (Proposed Condition) (DMA-A)

For Runoff Index = 74, AMC-II, $F_p = 0.48$ in/hr (**Exhibit-I**)

Time of concentration can be determined from Exhibit-G using the following parameters:

ΔE = Elevation difference between the longest flow path upper and lower most points = 15 feet

L = Flow path Length = 660 feet

Time of concentration ' t_c ' is found 8 minutes.

Rainfall intensity can be determined from Exhibit-L using the following parameters:

t_c = Time of concentration = 8 minutes

Slope, $S=0.7$ (for valley areas per SB County Hydrology Manual 'Section B.8')

100-Yr 1-hour Precipitation depth = 1.88 inch (**Exhibit-J**)

100-Yr Rainfall intensity for 8 min storm, $I = 7.8$ in/hr (**Exhibit-L**)

So, DMA-A 100-Year peak flow, $Q = C \times I \times A = 0.90(a_i + ((I-F_p)a_p)/I) \times I \times A$

$$Q = 0.90 \times (0.9 + ((7.8-0.48) \times 0.1) / 7.8) \times 7.8 \times 5.75 = 40.12 \text{ cfs}$$

Basin Design and Vol Mitigation Required (For 100-Year Storm Event)

Per " **Town of Yucca Valley Hydraulic Design Criteria and Facility Sizing**", the basin capacity and outlet sizes shall be such that **the post-development peak flow rate generated by the site shall be less than or equal to the pre-development peak flow rate from the site for 100-year rainfall and AMC II.**

100-Yr 1-hour Precipitation depth = 1.88 inch (**Exhibit-J**)

100-Yr Rainfall intensity for 15 min storm, $I = 5.0$ in/hr (**Exhibit-K**) (**Existing Condition**)

100-Yr Rainfall intensity for 8 min storm, $I = 7.8$ in/hr (**Exhibit-K**) (**Proposed Condition**)

$Q = 0.90 \times (0 + ((5.0-0.73) \times 1) / 5.0) \times 5.0 \times 5.75 = 22.1$ cfs (**Existing Condition**)

$Q = 0.90 \times (0.9 + ((7.8-0.48) \times 0.1) / 7.8) \times 7.8 \times 5.75 = 40.12$ cfs (**Proposed Condition**)

Differential of post- and 90% of the pre-development, $\Delta Q = 40.12$ cfs – 22.1 cfs = 18.02 cfs

Time of concentration, $T_c = 8$ min

Total Volume Mitigation Required after development = $1.5(\Delta Q)(T_c)(60) = 1.5 \times 18.02 \times 8 \times 60 = 12,975$ ft³

Water Quality Volume Requirement:

Disturbed Area, A = 215,000 ft²

Project Imperviousness, Imp% = 20% = 0.2

Runoff Coefficient, (R_c) = 0.858(Imp%)³-0.78(Imp%)²+0.774(Imp%)+0.04 = 0.73

1-hour rainfall depth for a 2-year return period (in), I_{1hr} = 0.486 in

Mean 6-hr Precipitation (inches), P₆ = I_{1hr} * C1 (where C1 is a function of site climatic region = 1.4807)

$$P_6 = 0.72$$

Design capture volume, DCV (ft³) = 1/12 * [A * R_c * P₆ * C2],

where C2 is a function of drawdown rate (48-hr = 1.963)

$$\text{So, DCV} = 1/12 * [215,000 * 0.73 * 0.72 * 1.963] = 18,486 \text{ ft}^3$$

Volume Provided by Infiltration basin:

dP=Ponding depth=0.5'

dG=Gravel depth=3'

Gravel porosity=0.4

dE=Total effective depth

$$\text{Total effective depth, dE} = dP + 0.4 \times dG = 0.5 + 0.4 \times 3 = 1.7$$

Infiltration basin volume

= Infiltrating surface x [Total effective depth + (Typical duration of storm + Drawdown time) x (Percolation rate/12)]

$$= 5,000 \text{ ft}^2 \times [1.7 \text{ ft} + (3+48) \times (1/12)]$$

$$= 8,500 \text{ cf} + 21,250 \text{ cf}$$

$$= 29,750 \text{ cf}$$

Volume provided by Infiltration basin = 29,750 CF > DCV 18,486 CF

$$= 29,750 \text{ CF} > \text{Flood control volume } 12,975 \text{ CF}$$

DISCUSSION OF ONSITE HYDROLOGY

For 100-yr storm event, existing watershed DMA-X (5.75 ac) produces 22.1 cfs runoff and the proposed watershed DMA-A (5.75 ac) produces 40.12 cfs runoff. To mitigate the additional runoff beyond pre-development conditions, an infiltration basin is proposed on the southerly of the site. The basin is sized to be adequate.

DISCUSSION OF OFFSITE WASH AND 100-YR FLOODPLAIN

The wash analysis is based on terrain data NAVD 1988 obtained from USGS Earth Explorer.

The project site is located in FEMA ‘Zone A’ and also a DWR Awareness area for 100-Yr storm event, at upstream there is wash named **WASH-Y** that makes its way from westerly to easterly side. During 100-Yr storm peak flow rate, the **WASH-Y** won’t flood the site. The analysis is provided in the following:

The **WASH-Y** watershed is about 6,500 acres. Unit Hydrograph Method used to calculate peak flows from the wash. From analysis peak flow is determined 12,095 cfs from **WASH-Y** watershed.

To measure any possible flood depth at the subject site, a simulated HEC-RAS model is generated for the subject site and for the **WASH-Y** using digital elevation data from USGS Earth Explorer.

Then a steady flow simulation was run using hydrograph data (12,095 **cfs peak flow**) as upstream input obtained from Unit Hydrograph Method and the percentage of grade along the wash (4%) as downstream data.

The HEC-RAS result [**Exhibit D**] shows sites nearest 100-Yr water surface elevation [**along X-Section 2,755**] is 3,335.23 ft (NAVD 1988 DATUM). Proposed finished floor elevation has to be 1’ (freeboard) higher than the 100-Yr water surface elevation of 3,335.23 ft (per **Town of Yucca Valley** Municipal Code). Off-site Hydraulic Calcs/Exhibits are attached in the **following**.

Off-site run-on summary:

Drainage Area	Area (AC)	Flow Path (ft)	Upstream Elevation (ft)	Downstream Elevation (ft)	Elevation Diff (ft)	Land Use	% Perv	Soil Type	SCS Curve Number
WASH-V	6,500	27,000	4,400	3,400	1000	Res/Com	70	B	86

PRE-DEVELOPMENT HYDROLOGY MAP

APN: 059-404-122
 55546 YUCCA TRAIL,
 TOWN OF YUCCA VALLEY, CA 92284

LEGAL DESCRIPTION:

LOT 07 APN 0594-041-22-0000
 ACCESSORS MAP BK. 0594
 SAN BERNARDINO COUNTY, CA

APPLICANT / OWNER / DEVELOPER

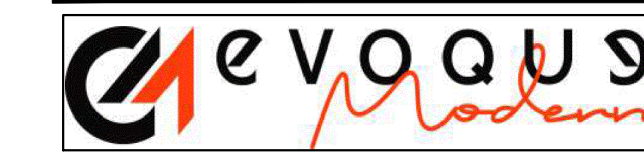

54934 TWENTYNINE PALMS HWY
 YUCCA VALLEY, CA 92284
 760-880-6436
 lfountain@evoquomodern.com

PROPOSED USE

0594-041-22-0000: STORAGE FACILITY/
 WAREHOUSING
 TOTAL GROSS AREA: 281,787 SQ. FT.
 TOTAL NET AREA: 275,230 SQ. FT.

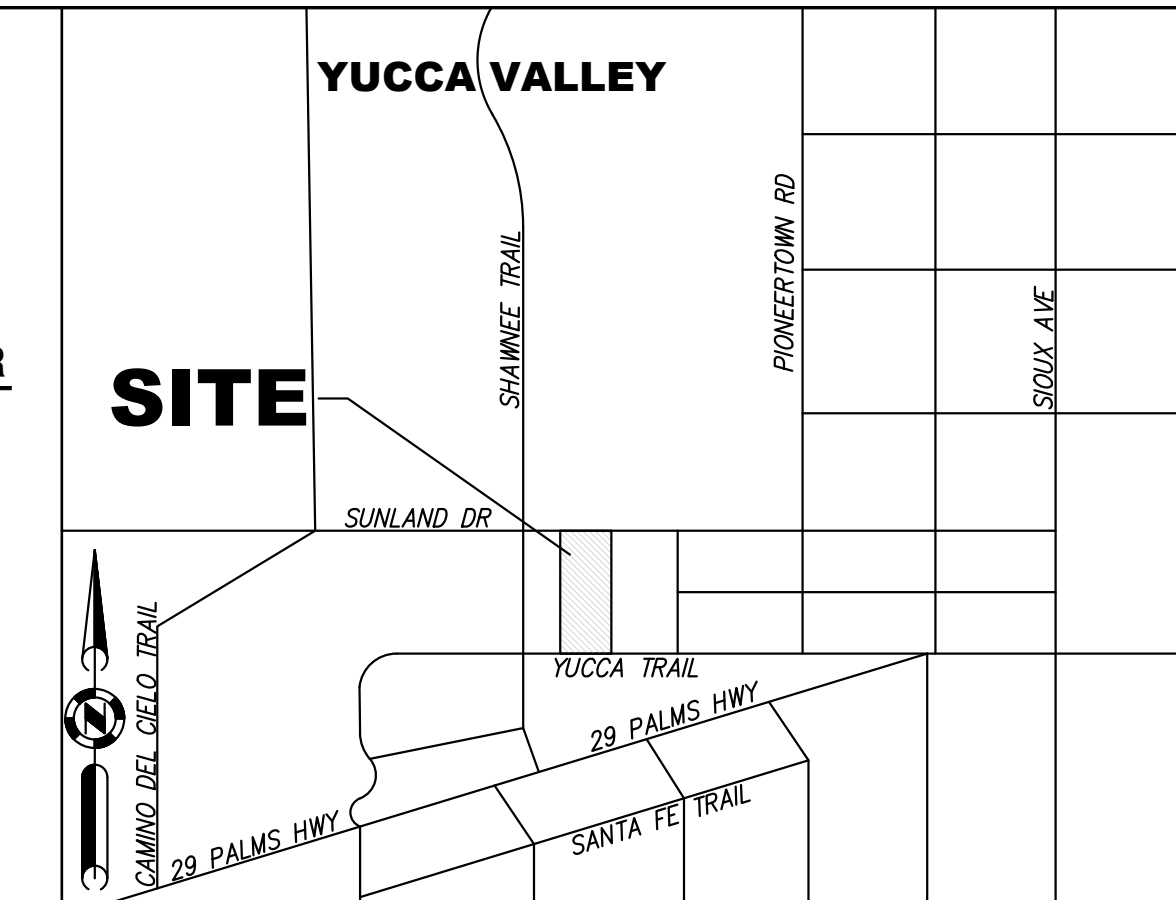

VICINITY MAP
NTS

LEGEND:

---	CENTERLINE	EP	EDGE OF PAVEMENT
---	PROPERTY LINE	FF	FINISHED FLOOR
---	WATER LINE	FG	FINISHED GROUND
---	SEWER LINE	FL	FLOW LINE
---	ELECTRIC LINE	FS	FINISHED SURFACE
---	GAS LINE	GB	GRADE BREAK
---	EXIST. CHAIN LINK FENCE	HP	HIGH POINT
---	EXIST. WOOD FENCE	INV	INVERT ELEVATION
---	EXIST. BLOCK WALL	PAD	PAD ELEVATION
---	EXIST. CONTOUR LINE	RET.	RETAINING WALL
---	EXIST. SPOT ELEVATION	TC	TOP OF CURB
---	EXIST. FIRE HYDRANT	TG	TOP OF GRATE
---	EXIST. POWER POLE		
---	EXIST. SEWER MANHOLE		
---	EXIST. STORM DRAIN MANHOLE		
---	EXIST. WATER METER		
---	EXIST. WATER VALVE		
---	EXIST. TREE		
---	CONCRETE PAVING		
---	LANDSCAPING		
---	GRASSCRETE PAVERS OR SIMILAR		
---	WOOD BOARDWALK		
---	DECOMPOSED GRANITE		

CONSTRUCTION NOTE:

- ① PROPOSED AC PAVEMENT
- ② PROPOSED 6" CURB AND GUTTER
- ③ PROPOSED DRIVEWAY APPROACH
- ④ PROPOSED CONC. PAVEMENT
- ⑤ PROPOSED CONC. RIBBON GUTTER
- ⑥ PROPOSED 36"x36" CATCH BASIN WITH TRAFFIC RATED STEEL GRATE
- ⑦ PROPOSED 18" RCP
- ⑧ SEE UTIL. NOTES/PLAN
- ⑨ SEE UTIL. NOTES/PLAN
- ⑩ SEE UTIL. NOTES/PLAN
- ⑪ PROPOSED TRASH ENCLOSURE
- ⑫ PROPOSED RET. WALL
- ⑬ SEE UTIL. NOTES/PLAN
- ⑭ SEE UTIL. NOTES/PLAN
- ⑮ SEE UTIL. NOTES/PLAN

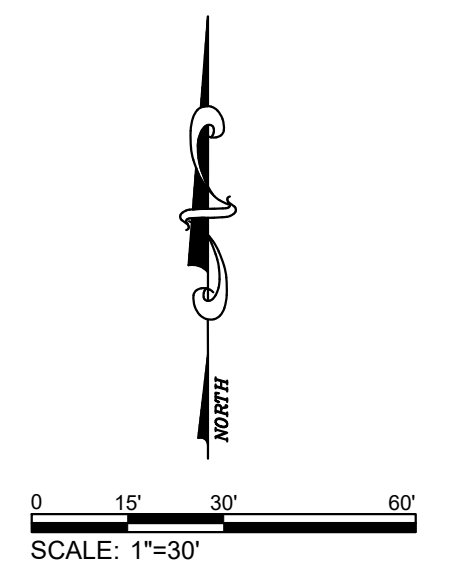

DMA-X=5.75 AC
PERVIOUS 100%
IMPERVIOUS 0%

PEAK FLOW
Q-100 =
22.1 CFS

L=770', S=3%

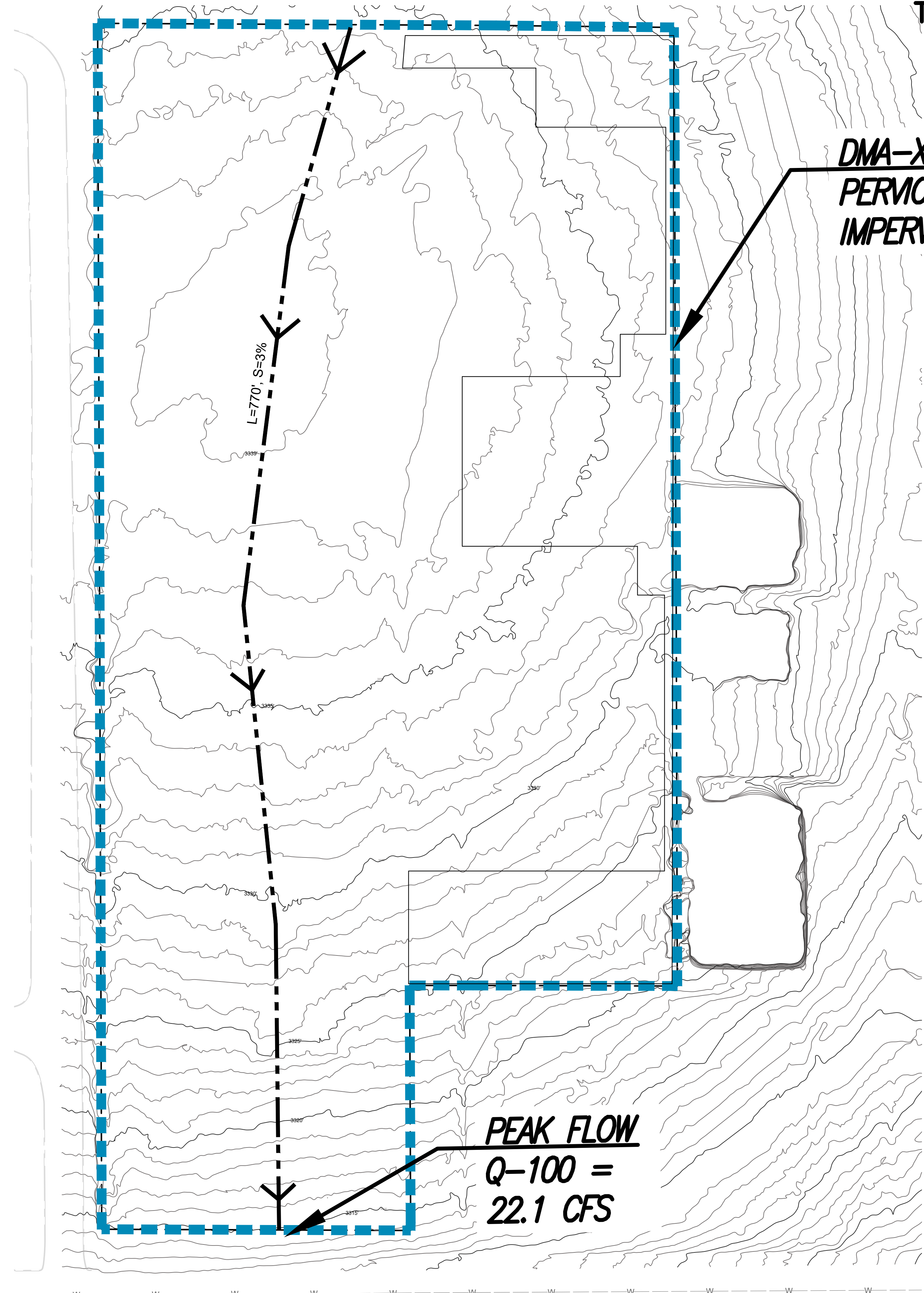

DRP ENTERPRISES LLC
 Daniel Patnequide
 MAILING ADDRESS:
 PO Box 4428
 Palm Springs, CA 92263
 206-734-7765
 Joanne C. Singer RCE 26900
 760-625-7426

POST-DEVELOPMENT HYDROLOGY MAP

APN: 059-404-122
 55546 YUCCA TRAIL,
 TOWN OF YUCCA VALLEY, CA 92284

LEGAL DESCRIPTION:

LOT 07 APN 0594-041-22-0000
 ACCESSORS MAP BK. 0594
 SAN BERNARDINO COUNTY, CA

APPLICANT / OWNER / DEVELOPER



54934 TWENTYNINE PALMS HWY
 YUCCA VALLEY, CA 92284
 760-880-6436
 info@evoquemodern.com

PROPOSED USE

0594-041-22-0000: STORAGE FACILITY/
 WAREHOUSING
 TOTAL GROSS AREA: 281,787 SQ. FT.
 TOTAL NET AREA: 275,230 SQ. FT.

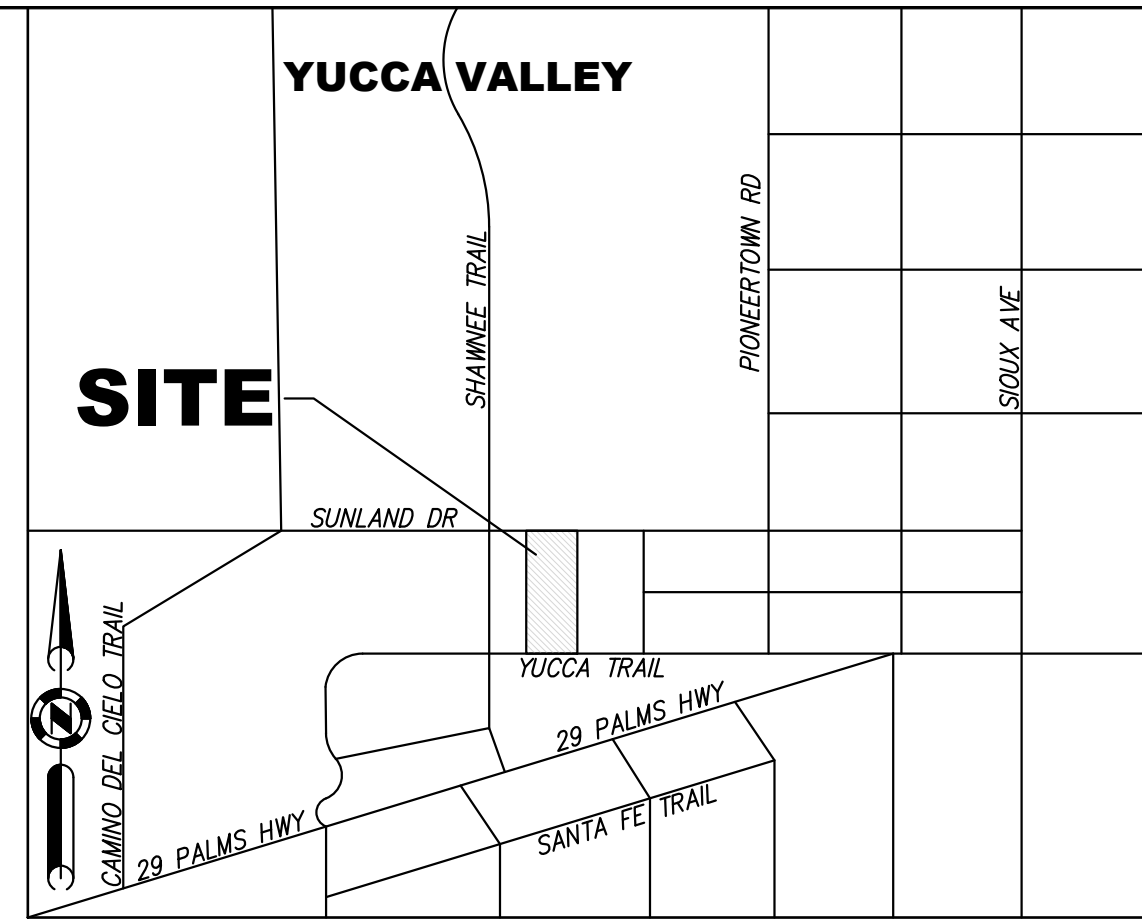

VICINITY MAP

LEGEND:

---	CENTERLINE	EP	EDGE OF PAVEMENT
---	PROPERTY LINE	FF	FINISHED FLOOR
---	WATER LINE	FG	FINISHED GROUND
---	SEWER LINE	FL	FLOW LINE
---	ELECTRIC LINE	FS	FINISHED SURFACE
---	GAS LINE	GB	GRADE BREAK
---	EXIST. CHAIN LINK FENCE	HP	HIGH POINT
---	EXIST. WOOD FENCE	INV	INVERT ELEVATION
---	EXIST. BLOCK WALL	PAD	PAD ELEVATION
---	EXIST. CONTOUR LINE	RET.	RETAINING WALL
---	EXIST. SPOT ELEVATION	TC	TOP OF CURB
---	EXIST. FIRE HYDRANT	TG	TOP OF GRATE
---	EXIST. POWER POLE		
---	EXIST. SEWER MANHOLE		
---	EXIST. STORM DRAIN MANHOLE		
---	EXIST. WATER METER		
---	EXIST. WATER VALVE		
---	EXIST. TREE		
---	CONCRETE PAVING		
---	LANDSCAPING		
---	GRASSCRETE PAVERS OR SIMILAR		
---	WOOD BOARDWALK		
---	DECOMPOSED GRANITE		

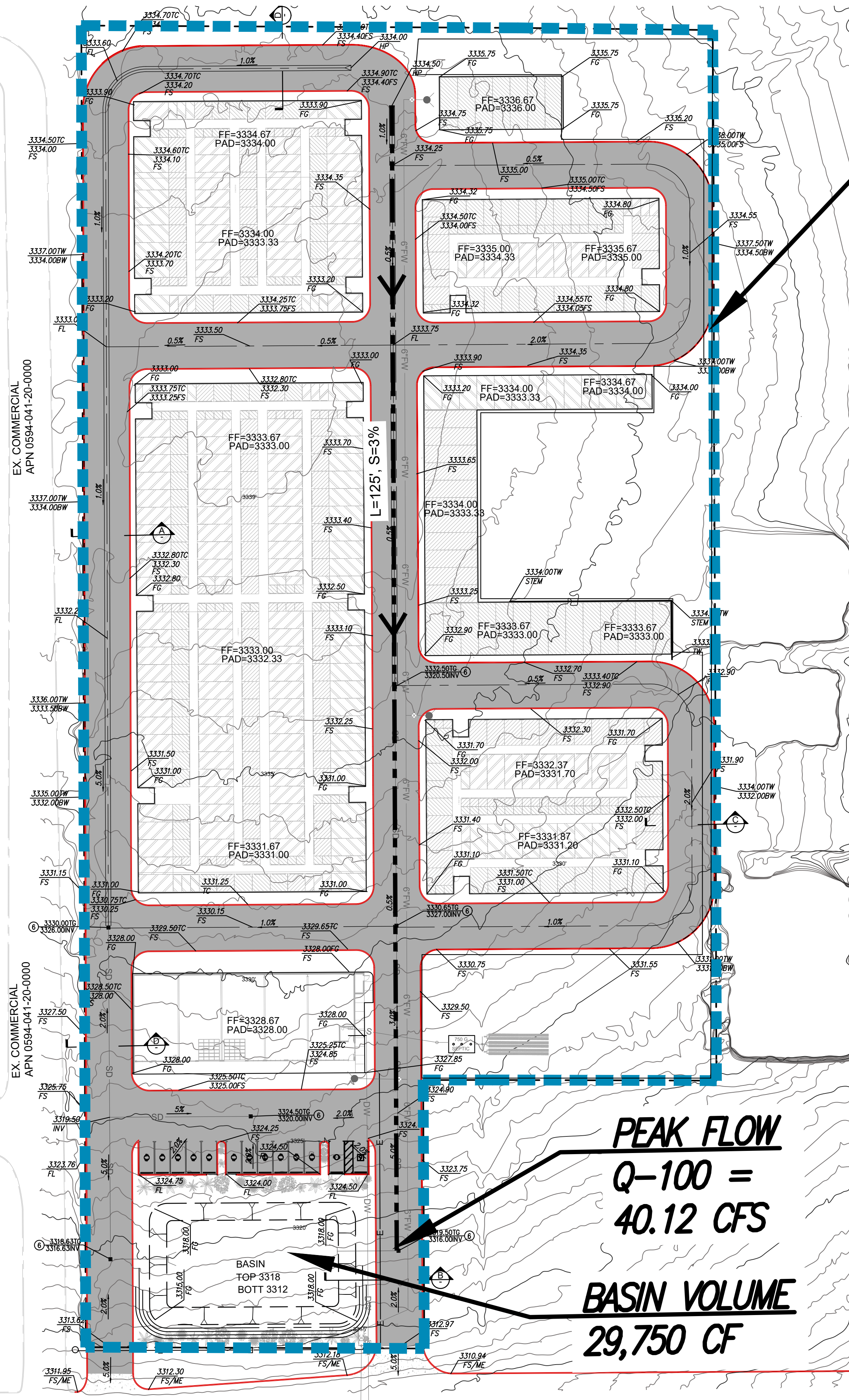

DMA-A=5.75 AC
PERVIOUS 10%
IMPERVIOUS 90%

PEAK FLOW
Q-100 =
40.12 CFS

BASIN VOLUME
29,750 CF

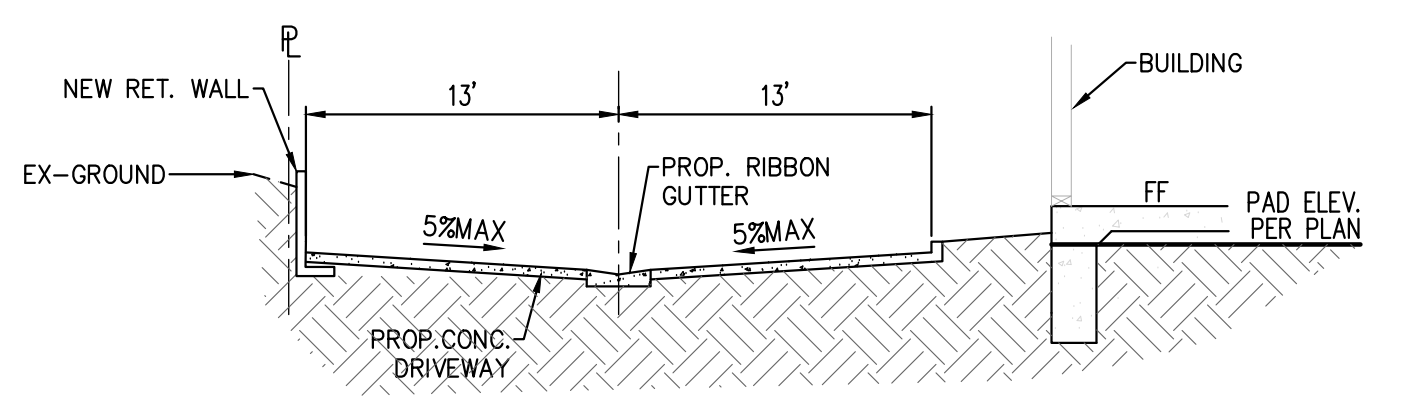

SECTION 'A'
N.T.S.

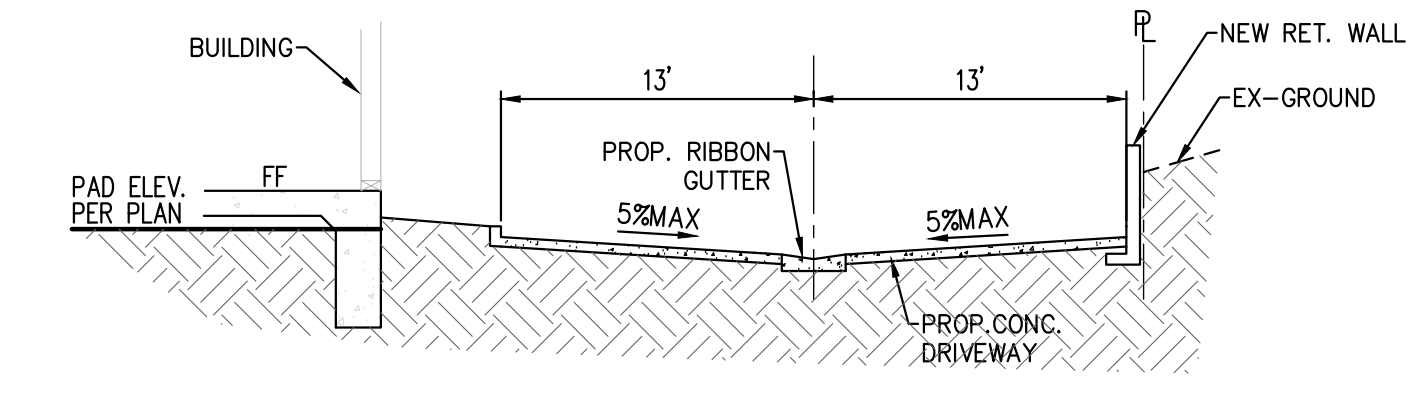

SECTION 'C'
N.T.S.

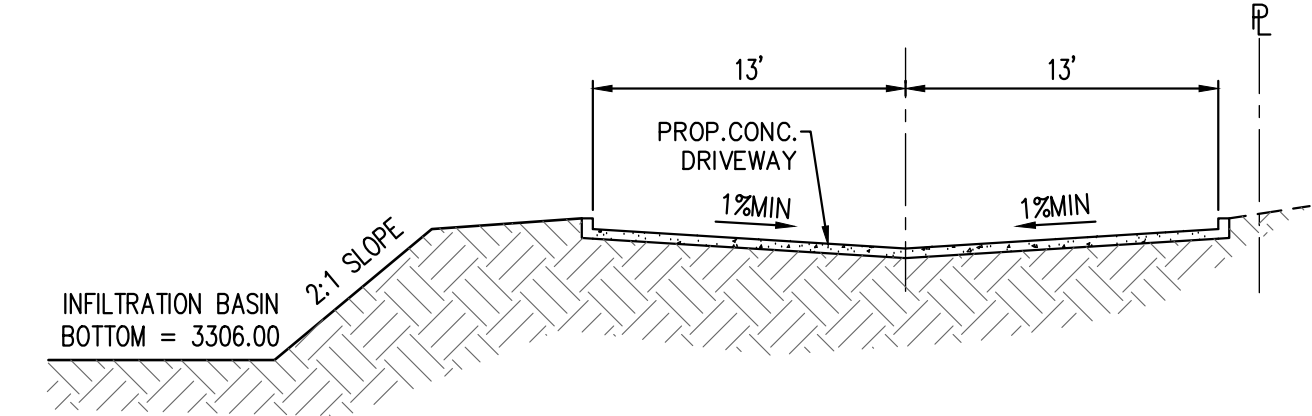

SECTION 'B'
N.T.S.

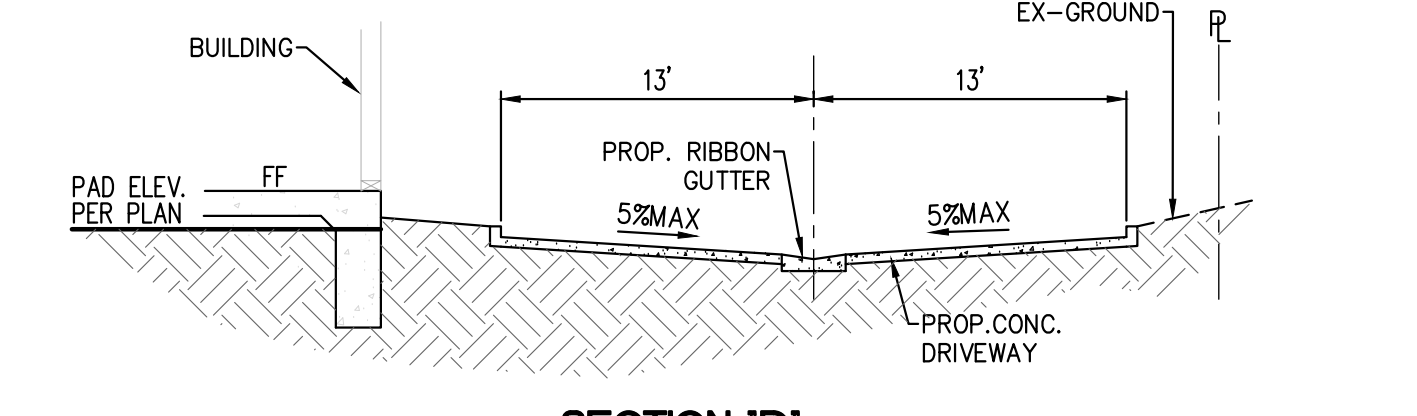

SECTION 'D'
N.T.S.

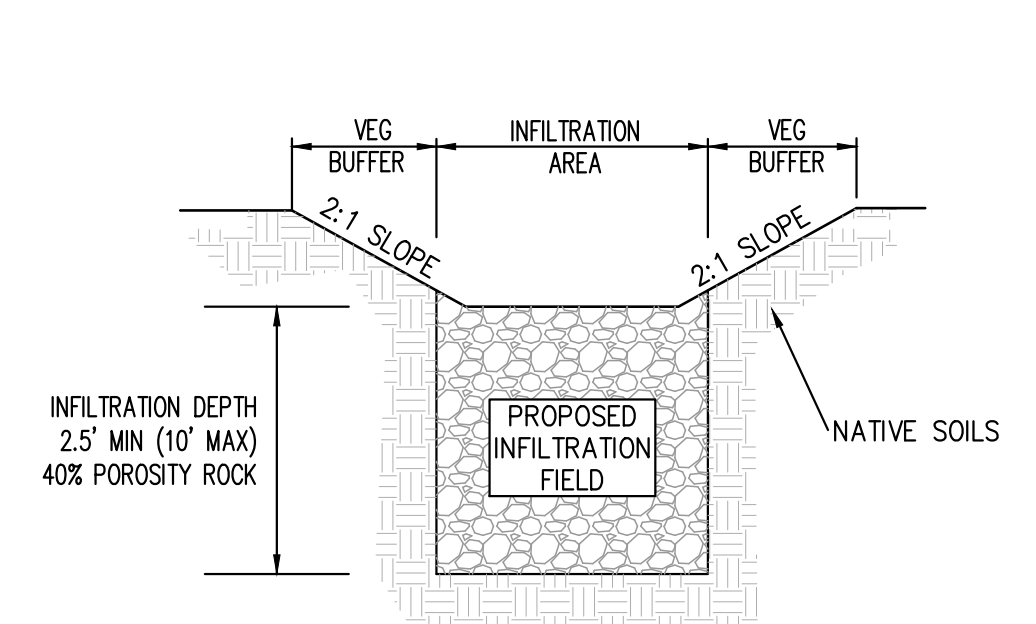

INFILTRATION BASIN DETAIL
N.T.S.

dP=PONDING DEPTH=0.5'
 dG=GRAVEL DEPTH=3'
 GRAVEL POROSITY=0.4
 dE=TOTAL EFFECTIVE DEPTH

TOTAL EFFECTIVE DEPTH, dE = dP+0.4XdG
 = 0.5+0.4X3
 = 1.7

BIO-RETENTION BASIN VOLUME = INFILTRATING SURFACE X (TOTAL EFFECTIVE DEPTH + (TYPICAL DURATION OF STORM + DRAWDOWN TIME) * (PERCOLATION RATE / 12))

INFILTRATION BASIN VOLUME = 5,000 FT² X [1.7 FT + (3+48)*(1/12)]
 = 8,500 CF + 21,250 CF
 = 29,750 CF

APPLICANT / OWNER / DEVELOPER



54934 TWENTYNINE PALMS HWY
YUCCA VALLEY, CA 92284
760-880-6436
lafontaine@evoquemodern.com

WASH ANALYSIS

APN: 059-404-122
55546 YUCCA TRAIL,
TOWN OF YUCCA VALLEY, CA 92284
SAN BERNARDINO COUNTY

VICINITY MAP

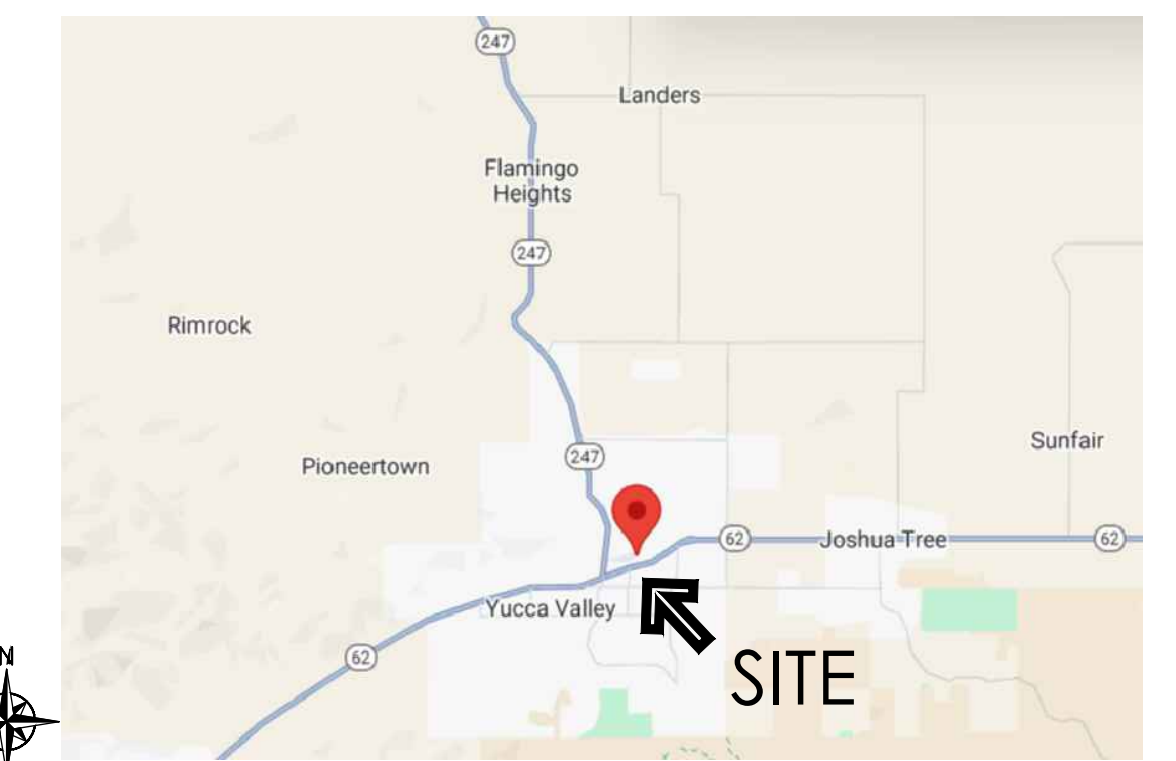

VICINITY MAP
NTS

LEGEND:

-  DRAINAGE AREA BOUNDARY
-  DRAINAGE AREA BOUNDARY

WASH-Y
WATERSHED
6,500 AC

100-YR
PEAK FLOW
12,095 CFS

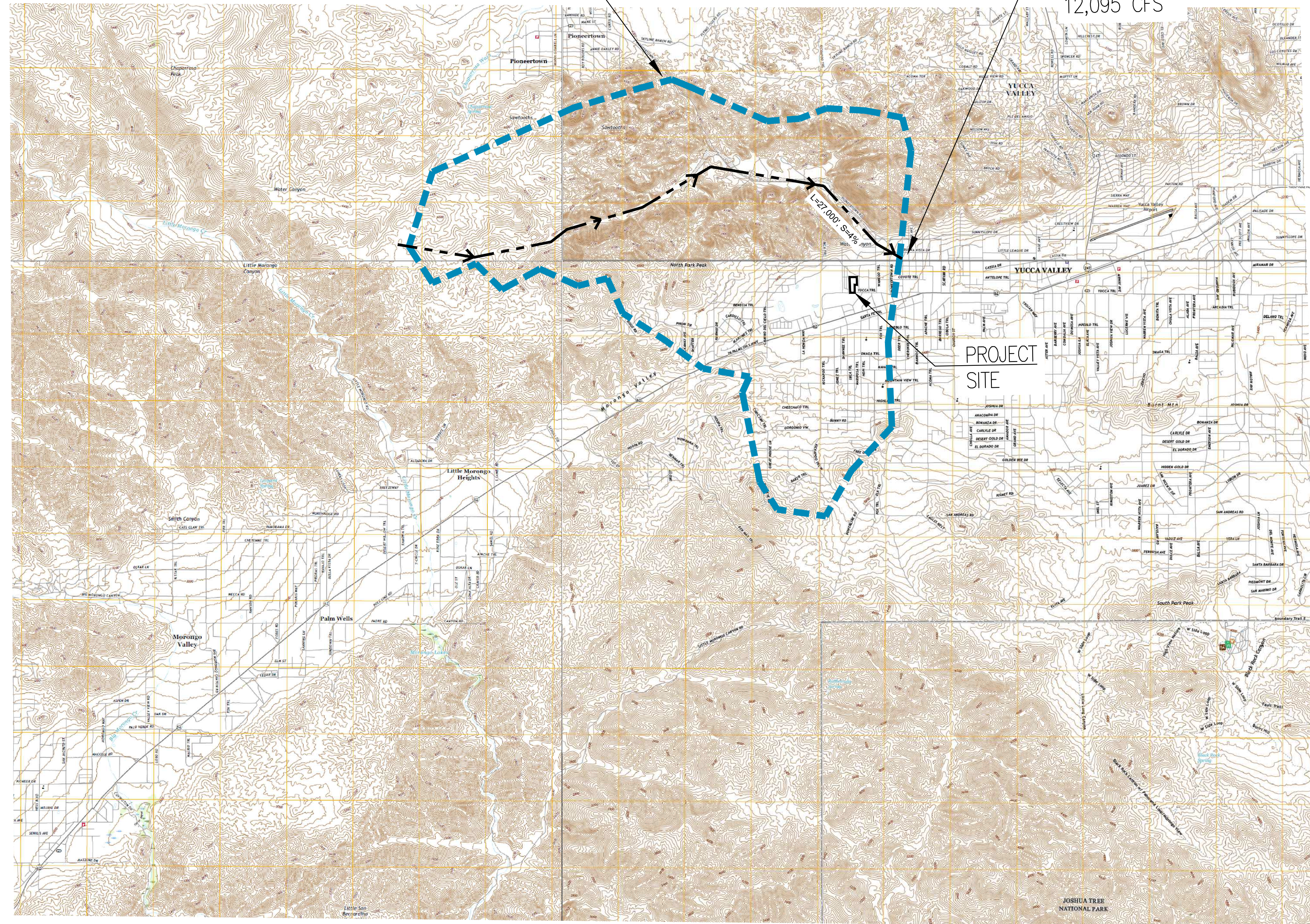

CIVIL ENGINEER

DRP ENTERPRISES LLC
DANIEL PATNEAUDE
MAILING ADDRESS:
PO BOX 4428
PALM SPRINGS, CA 92263
JOANNE C. SINGER, RCE 26900
(760) 625-7426

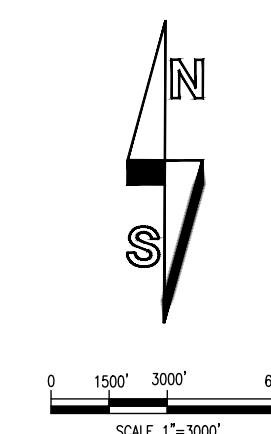

HEC-RAS RESULTS

APN: 059-404-122
 55546 YUCCA TRAIL,
 TOWN OF YUCCA VALLEY, CA 92284
 SAN BERNARDINO COUNTY

VICINITY MAP

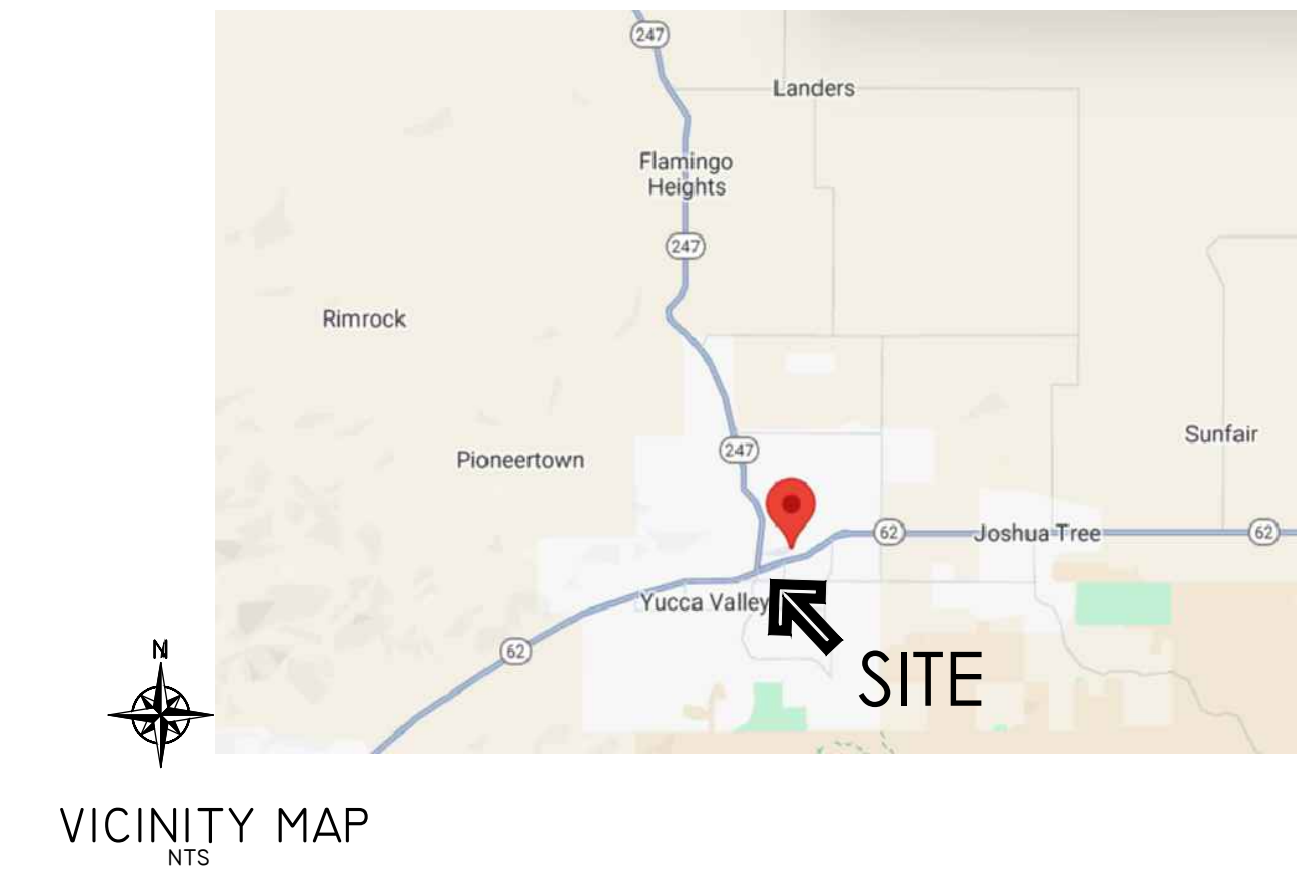

SITE IS LOCATED HERE
 ALONG X-SEC: 2755

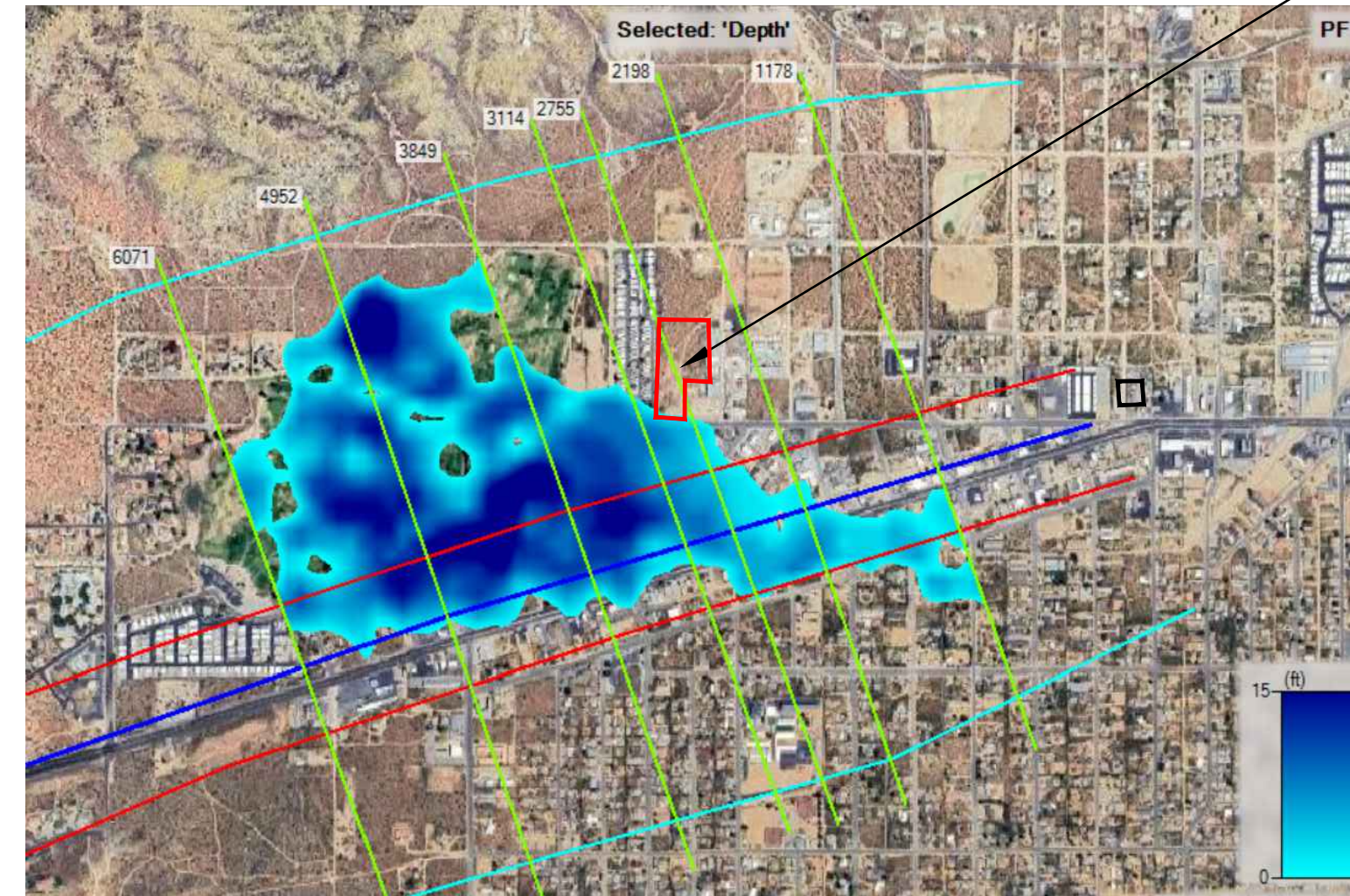

X-SEC/STATION: 2755

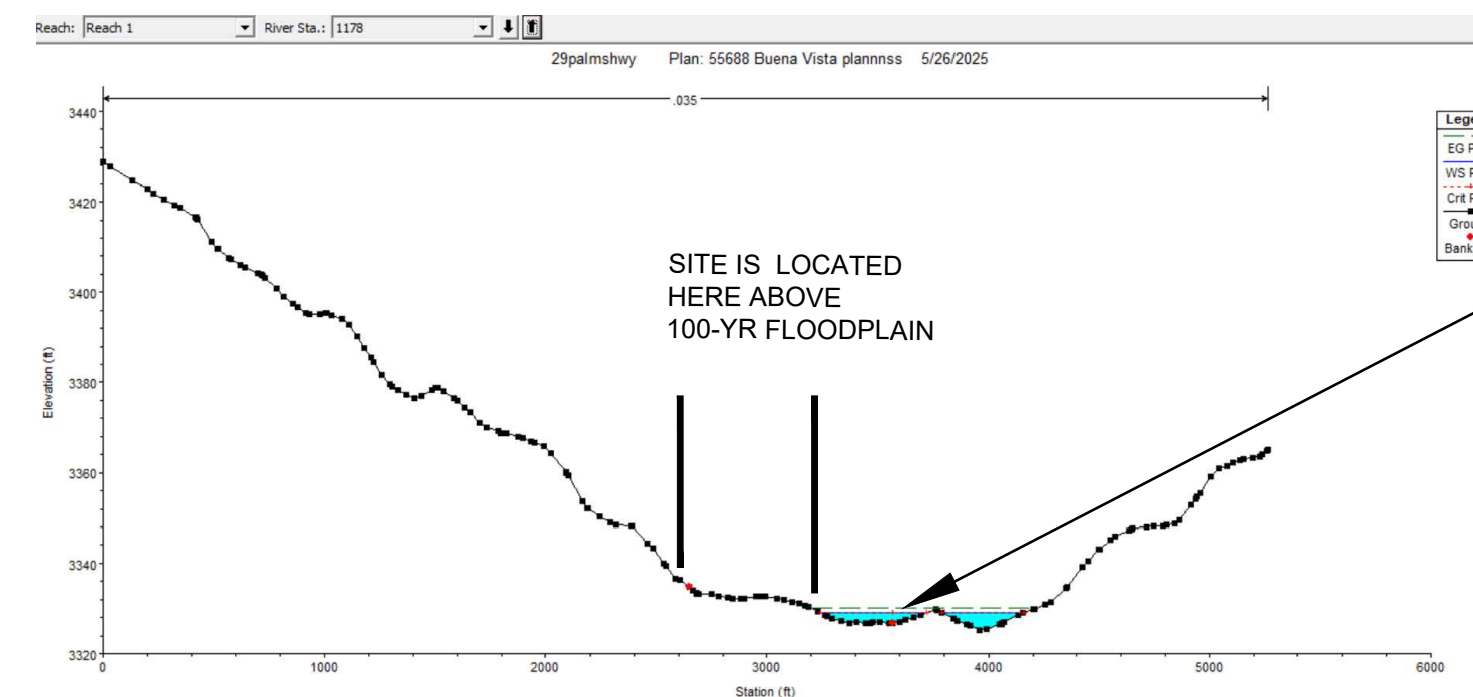

STATION 2755:
 MAX WSE=3,335.23' (NAVD88)
 DUE TO UPSTREAM WASHES
 @100-YR STORM EVENT

APPLICANT / OWNER / DEVELOPER



54934 TWENTYNINE PALMS HWY
 YUCCA VALLEY, CA 92284
 760-880-6436
 lafountaine@evoquomodern.com

HEC-RAS RESULTS

Reach	River Sta	Profile	Q Total (cfs)	Min Ch El (ft)	W.S. Elev (ft)	Crit W.S. (ft)	E.G. Elev (ft)	E.G. Slope (ft/ft)	Vel Chnl (ft/s)	Flow Area (sq ft)	Top Width (ft)	Froude # Chl
Reach 1	6071	PF 1	12095.00	3328.01	3335.34		3335.48	0.000671	3.11	4048.90	907.29	0.25
Reach 1	4952	PF 1	12095.00	3320.44	3335.42		3335.42	0.000006	0.44	25350.38	2463.03	0.03
Reach 1	3849	PF 1	12095.00	3323.76	3335.40		3335.41	0.000013	0.67	18026.57	2127.51	0.04
Reach 1	3114	PF 1	12095.00	3326.63	3335.35		3335.39	0.000108	1.52	8144.75	1320.32	0.11
Reach 1	2755	PF 1	12095.00	3329.75	3335.23		3335.31	0.000451	2.44	5320.45	1414.97	0.20
Reach 1	2198	PF 1	12095.00	3326.86	3334.45	3331.89	3334.80	0.002262	4.79	2525.07	690.77	0.44
Reach 1	1178	PF 1	12095.00	3326.72	3329.09	3329.09	3330.01	0.014126	7.60	1571.02	850.34	0.99

STATION 2755:
 100-YR STORM MAX
 WATER SURFACE ELEV.
 =3,335.23' (NAVD 88)

CIVIL ENGINEER



DRP ENTERPRISES LLC
 DANIEL PATNEAUDE
 MAILING ADDRESS:
 PO BOX 4428
 PALM SPRINGS, CA 92263
 JOANNE C. SINGER, RCE 26900
 (760) 625-7426

Watershed Model Schematic

Hydraflow Hydrographs Extension for Autodesk® Civil 3D® by Autodesk, Inc. v2023

1



Legend

Hyd. Origin Description

1 SCS Runoff WASH-Y

Hydrograph Return Period Recap

Hydraflow Hydrographs Extension for Autodesk® Civil 3D® by Autodesk, Inc. v2023

Hyd. No.	Hydrograph type (origin)	Inflow hyd(s)	Peak Outflow (cfs)								Hydrograph Description
			1-yr	2-yr	3-yr	5-yr	10-yr	25-yr	50-yr	100-yr	
1	SCS Runoff	-----	-----	1889.60	-----	-----	5402.12	-----	-----	12095.08	WASH-Y

Hydrograph Summary Report

Hydraflow Hydrographs Extension for Autodesk® Civil 3D® by Autodesk, Inc. v2023

Hyd. No.	Hydrograph type (origin)	Peak flow (cfs)	Time interval (min)	Time to Peak (min)	Hyd. volume (cuft)	Inflow hyd(s)	Maximum elevation (ft)	Total strge used (cuft)	Hydrograph Description
1	SCS Runoff	12095.08	2	798	148,245,824	-----	-----	-----	WASH-Y
55546 yucca trail.gpw					Return Period: 100 Year		Tuesday, 05 / 20 / 2025		

Hydrograph Report

Hydraflow Hydrographs Extension for Autodesk® Civil 3D® by Autodesk, Inc. v2023

Tuesday, 05 / 20 / 2025

Hyd. No. 1

WASH-Y

Hydrograph type	= SCS Runoff	Peak discharge	= 12095.08 cfs
Storm frequency	= 100 yrs	Time to peak	= 13.30 hrs
Time interval	= 2 min	Hyd. volume	= 148,245,824 cuft
Drainage area	= 6500.000 ac	Curve number	= 86*
Basin Slope	= 0.0 %	Hydraulic length	= 0 ft
Tc method	= TR55	Time of conc. (Tc)	= 139.50 min
Total precip.	= 7.95 in	Distribution	= Type II
Storm duration	= 24 hrs	Shape factor	= 484

* Composite (Area/CN) = [(15500.000 x 86)] / 6500.000

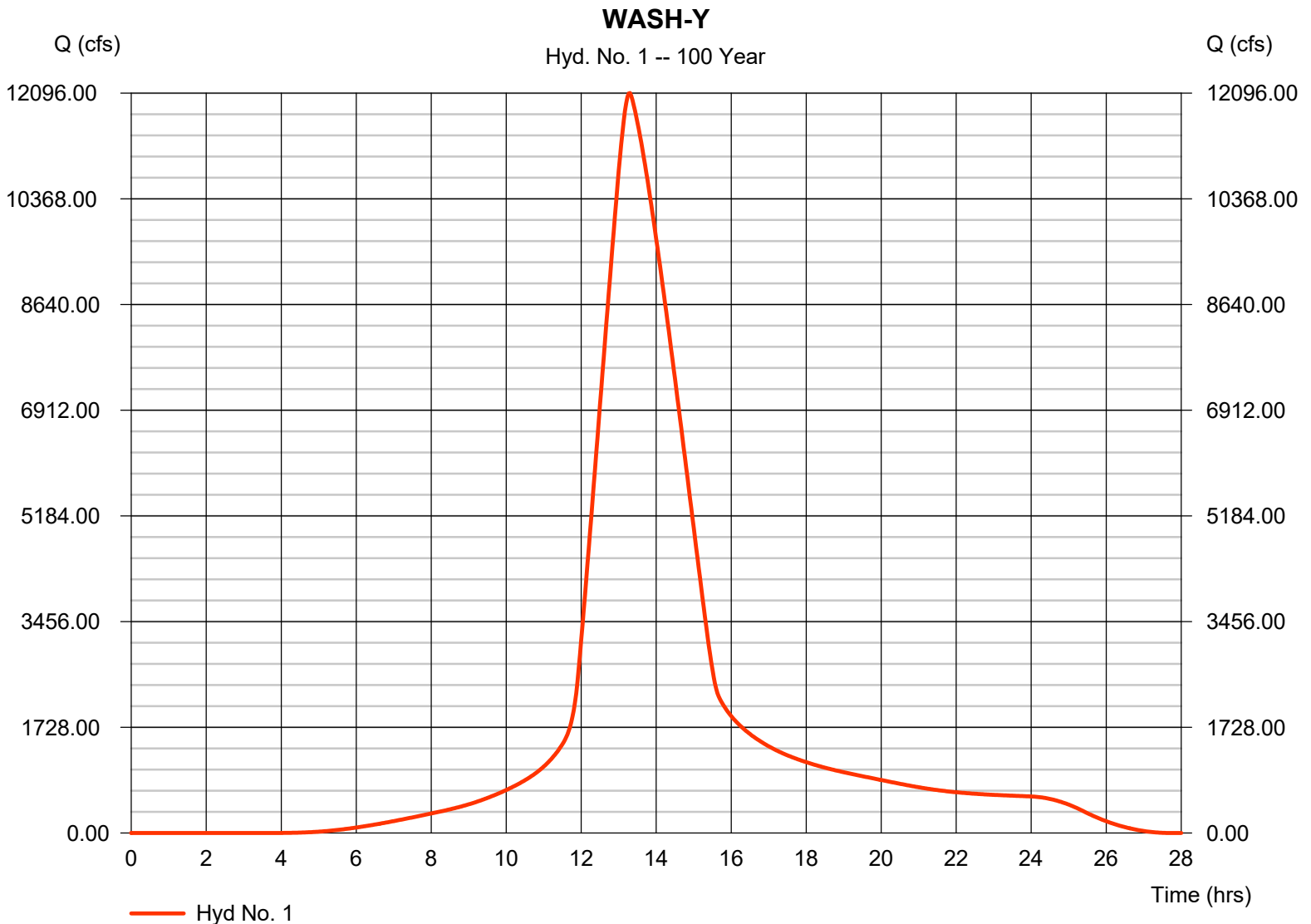

TR55 Tc Worksheet

Hydraflow Hydrographs Extension for Autodesk® Civil 3D® by Autodesk, Inc. v2023

Hyd. No. 1

WASH-Y

<u>Description</u>	<u>A</u>	<u>B</u>	<u>C</u>	<u>Totals</u>
Sheet Flow				
Manning's n-value	= 0.011	0.011	0.011	
Flow length (ft)	= 0.0	0.0	0.0	
Two-year 24-hr precip. (in)	= 0.00	0.00	0.00	
Land slope (%)	= 0.00	0.00	0.00	
Travel Time (min)	= 0.00	+ 0.00	+ 0.00	= 0.00
Shallow Concentrated Flow				
Flow length (ft)	= 27000.00	0.00	0.00	
Watercourse slope (%)	= 4.00	0.00	0.00	
Surface description	= Unpaved	Paved	Paved	
Average velocity (ft/s)	=3.23	0.00	0.00	
Travel Time (min)	= 139.45	+ 0.00	+ 0.00	= 139.45
Channel Flow				
X sectional flow area (sqft)	= 0.00	0.00	0.00	
Wetted perimeter (ft)	= 0.00	0.00	0.00	
Channel slope (%)	= 0.00	0.00	0.00	
Manning's n-value	= 0.015	0.015	0.015	
Velocity (ft/s)	=0.00	0.00	0.00	
Flow length (ft)	({0})0.0	0.0	0.0	
Travel Time (min)	= 0.00	+ 0.00	+ 0.00	= 0.00
Total Travel Time, Tc				139.50 min

Hydraflow Rainfall Report

Return Period (Yrs)	Intensity-Duration-Frequency Equation Coefficients (FHA)			
	B	D	E	(N/A)
1	4.5772	3.7000	0.6352	-----
2	6.6734	3.8000	0.6405	-----
3	0.0000	0.0000	0.0000	-----
5	9.2909	3.7000	0.6337	-----
10	12.1470	3.9000	0.6409	-----
25	16.2816	4.0000	0.6458	-----
50	19.0109	3.8000	0.6382	-----
100	23.1841	4.0000	0.6443	-----

File name: 55546 yucca trail.IDF

Intensity = B / (Tc + D)^E

Return Period (Yrs)	Intensity Values (in/hr)											
	5 min	10	15	20	25	30	35	40	45	50	55	60
1	1.16	0.87	0.71	0.61	0.54	0.49	0.45	0.42	0.39	0.36	0.34	0.33
2	1.66	1.24	1.02	0.88	0.78	0.70	0.64	0.59	0.55	0.52	0.49	0.47
3	0.00	0.00	0.00	0.00	0.00	0.00	0.00	0.00	0.00	0.00	0.00	0.00
5	2.36	1.77	1.45	1.25	1.11	1.00	0.92	0.85	0.79	0.74	0.70	0.67
10	2.99	2.25	1.85	1.59	1.41	1.27	1.16	1.08	1.00	0.94	0.89	0.85
25	3.94	2.96	2.43	2.09	1.85	1.67	1.53	1.41	1.32	1.24	1.17	1.11
50	4.74	3.56	2.92	2.51	2.23	2.01	1.84	1.70	1.59	1.49	1.41	1.34
100	5.63	4.23	3.48	2.99	2.65	2.39	2.19	2.02	1.89	1.77	1.68	1.59

Tc = time in minutes. Values may exceed 60.

Precip. file name: Sample.pcp

Storm Distribution	Rainfall Precipitation Table (in)							
	1-yr	2-yr	3-yr	5-yr	10-yr	25-yr	50-yr	100-yr
SCS 24-hour	0.00	2.20	0.00	3.30	4.25	5.77	6.80	7.95
SCS 6-Hr	0.00	1.80	0.00	0.00	2.60	0.00	0.00	4.00
Huff-1st	0.00	1.55	0.00	2.75	4.00	5.38	6.50	8.00
Huff-2nd	0.00	0.00	0.00	0.00	0.00	0.00	0.00	0.00
Huff-3rd	0.00	0.00	0.00	0.00	0.00	0.00	0.00	0.00
Huff-4th	0.00	0.00	0.00	0.00	0.00	0.00	0.00	0.00
Huff-Indy	0.00	0.00	0.00	0.00	0.00	0.00	0.00	0.00
Custom	0.00	1.75	0.00	2.80	3.90	5.25	6.00	7.10

Hydraflow Table of Contents

Watershed Model Schematic.....	1
Hydrograph Return Period Recap.....	2
100 - Year	
Summary Report.....	3
Hydrograph Reports.....	4
Hydrograph No. 1, SCS Runoff, WASH-Y.....	4
TR-55 Tc Worksheet.....	5
IDF Report.....	6

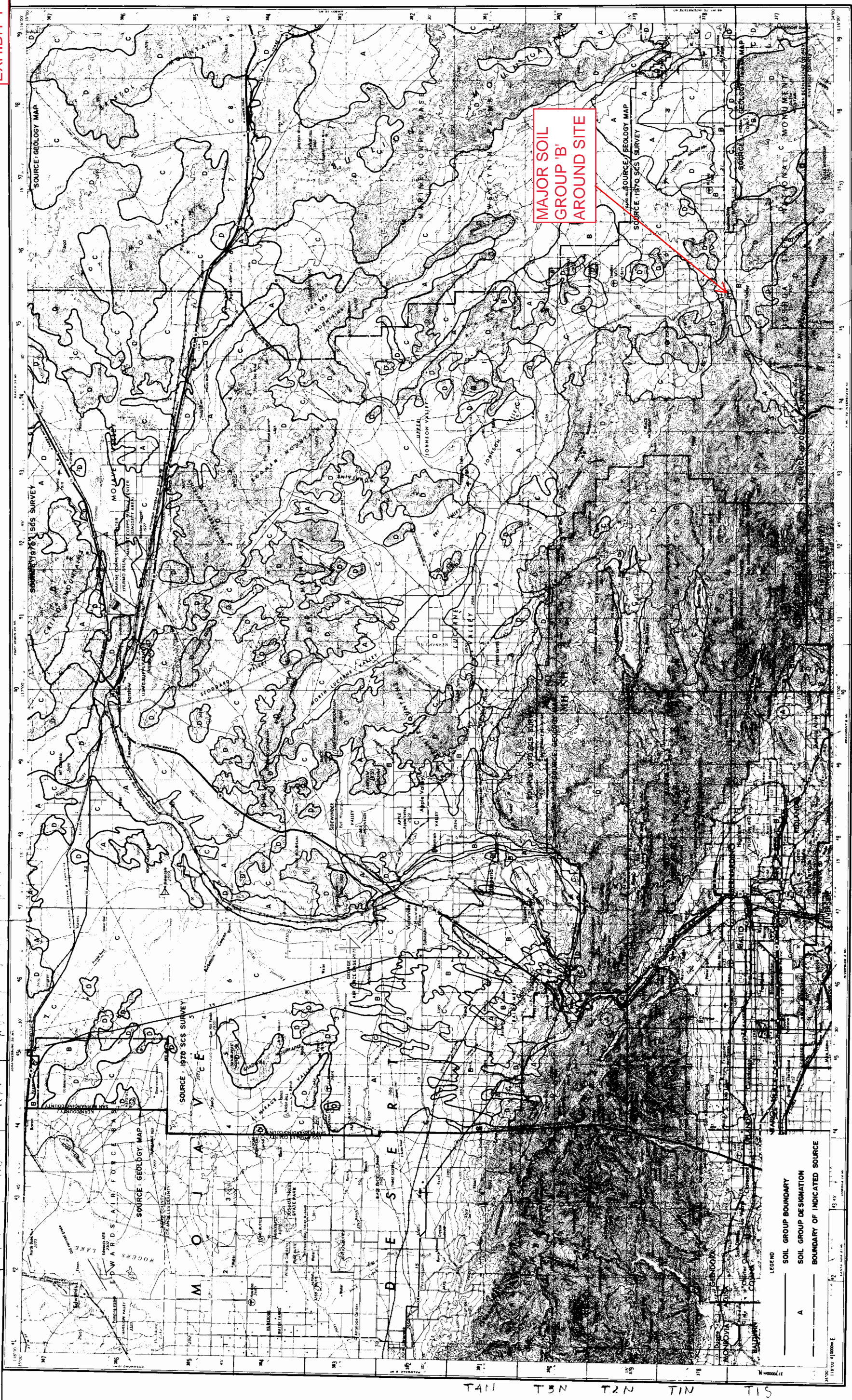

MAJOR SOIL GROUP 'B' AROUND SITE

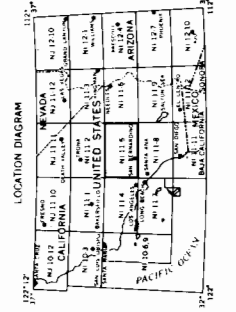

Scale 1:250,000
 WITH SUPPLEMENTARY CONTOURS AT 100 FOOT INTERVALS
 CONTOUR INTERVAL 200 FEET
 TRANSVERSE MERCATOR PROJECTION
 BLACK NUMBERED LINES INDICATE THE GRID WITH UNIVERSAL TRANSVERSE MERCATOR ZONE 11
 1983 MAGNETIC DECLINATION FROM TRUE NORTH VARIES FROM 14M 12M 10M 8M 6M 4M 2M 0M 2M 4M 6M 8M 10M 12M 14M
 THE CENTER OF THE GRID IS TO THE WEST OF THE CENTER OF THE EAST EDGE
 BASE MAP REPRODUCED FROM U.S.G.S. "SAN BERNARDINO" TOPOGRAPHIC MAP
SCALE REDUCED BY 1/2

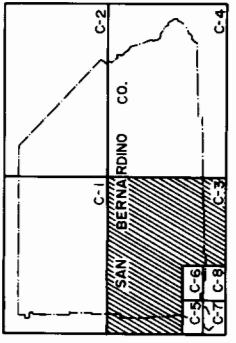

INDEX MAP

LEGEND
 SOIL GROUP BOUNDARY
 SOIL GROUP DESIGNATION
 BOUNDARY OF INDICATED SOURCE

SAN BERNARDINO COUNTY
HYDROLOGY MANUAL

HYDROLOGIC SOILS GROUP MAP
FOR
SOUTHCENTRAL AREA

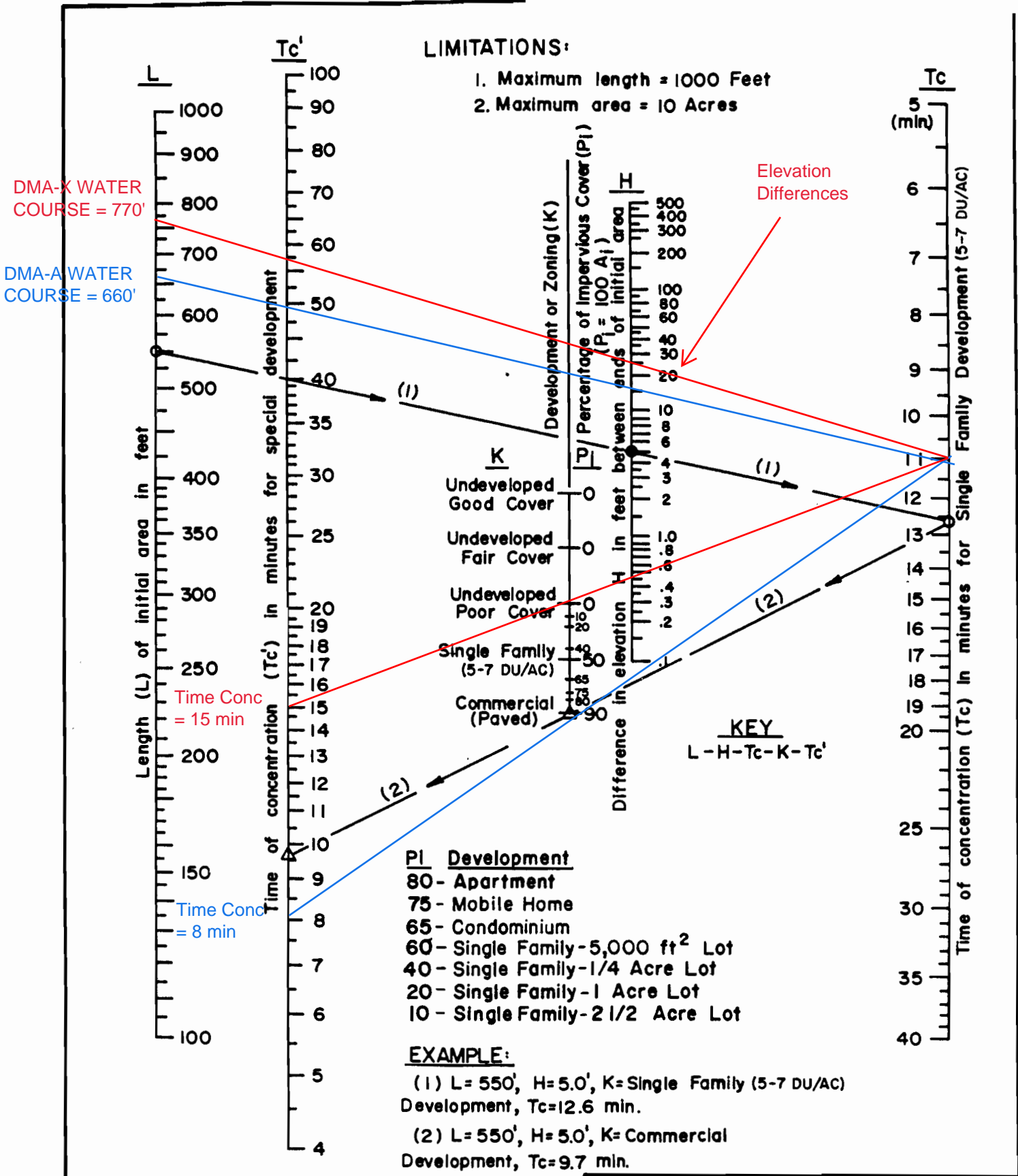

SAN BERNARDINO COUNTY
HYDROLOGY MANUAL

TIME OF CONCENTRATION
NOMOGRAPH
FOR INITIAL SUBAREA

Curve (1) Numbers of Hydrologic Soil-Cover Complexes For Pervious Areas-AMC II					
Cover Type (3)	Quality of Cover (2)	Soil Group			
		A	B	C	D
<u>NATURAL COVERS -</u>					
Barren (Rockland, eroded and graded land)		78	86	91	93
Chaparral, Broadleaf (Manzonita, ceanothus and scrub oak)	Poor	53	70	80	85
	Fair	40	63	75	81
	Good	31	57	71	78
Chaparral, Narrowleaf (Chamise and redshank)	Poor	71	82	88	91
	Fair	55	72	81	86
Grass, Annual or Perennial	Poor	67	78	86	89
	Fair	50	69	79	84
	Good	38	61	74	80
Meadows or Cienegas (Areas with seasonally high water table, principal vegetation is sod forming grass)	Poor	63	77	85	88
	Fair	51	70	80	84
	Good	30	58	71	78
Open Brush (Soft wood shrubs - buckwheat, sage, etc.)	Poor	62	76	84	88
	Fair	46	66	77	83
	Good	41	63	75	81
Woodland (Coniferous or broadleaf trees predominate. Canopy density is at least 50 percent.)	Poor	45	66	77	83
	Fair	36	60	73	79
	Good	25	55	70	77
Woodland, Grass (Coniferous or broadleaf trees with canopy density from 20 to 50 percent)	Poor	57	73	82	86
	Fair	44	65	77	82
	Good	33	58	72	79
<u>URBAN COVERS -</u>					
Residential or Commercial Landscaping (Lawn, shrubs, etc.)	Good	32	56	69	75
Turf (Irrigated and mowed grass)	Poor	58	74	83	87
	Fair	44	65	77	82
	Good	33	58	72	79
<u>AGRICULTURAL COVERS -</u>					
Fallow (Land plowed but not tilled or seeded)		77	86	91	94
SAN BERNARDINO COUNTY		CURVE NUMBERS			
HYDROLOGY MANUAL		FOR			
		PERVIOUS AREAS			

Curve (I) Numbers of Hydrologic Soil-Cover Complexes For Pervious Areas-AMC II

Cover Type (3)	Quality of Cover (2)	Soil Group			
		A	B	C	D
AGRICULTURAL COVERS (Continued)					
Legumes, Close Seeded (Alfalfa, sweetclover, timothy, etc.)	Poor	66	77	85	89
	Good	58	72	81	85
Orchards, Evergreen (Citrus, avocados, etc.)	Poor	57	73	82	86
	Fair	44	65	77	82
	Good	33	58	72	79
Pasture, Dryland (Annual grasses)	Poor	68	79	86	89
	Fair	49	69	79	84
	Good	39	61	74	80
Pasture, Irrigated (Legumes and perennial grass)	Poor	58	74	83	87
	Fair	44	65	77	82
	Good	33	58	72	79
Row Crops (Field crops - tomatoes, sugar beets, etc.)	Poor	72	81	88	91
	Good	67	78	85	89
Small grain (Wheat, oats, barley, etc.)	Poor	65	76	84	88
	Good	63	75	83	87

Notes:

- All curve numbers are for Antecedent Moisture Condition (AMC) II.
- Quality of cover definitions:
 Poor-Heavily grazed, regularly burned areas, or areas of high burn potential. Less than 50 percent of the ground surface is protected by plant cover or brush and tree canopy.
 Fair-Moderate cover with 50 percent to 75 percent of the ground surface protected.
 Good-Heavy or dense cover with more than 75 percent of the ground surface protected.
- See Figure C-2 for definition of cover types.

SAN BERNARDINO COUNTY
HYDROLOGY MANUAL

CURVE NUMBERS
FOR
PERVIOUS AREAS

ACTUAL IMPERVIOUS COVER		
Land Use (1)	Range-Percent	Recommended Value For Average Conditions-Percent (2)
Natural or Agriculture	0 - 0	0
Public Park	10 - 25	15
School	30 - 50	40
Single Family Residential: (3)		
2.5 acre lots	5 - 15	10
1 acre lots	10 - 25	20
2 dwellings/acre	20 - 40	30
3-4 dwellings/acre	30 - 50	40
5-7 dwellings/acre	35 - 55	50
8-10 dwellings/acre	50 - 70	60
More than 10 dwellings/acre	65 - 90	80
Multiple Family Residential:		
Condominiums	45 - 70	65
Apartments	65 - 90	80
Mobile Home Park	60 - 85	75
Commercial, Downtown Business or Industrial	80 - 100	90

Notes:

1. Land use should be based on ultimate development of the watershed. Long range master plans for the County and incorporated cities should be reviewed to insure reasonable land use assumptions.
2. Recommended values are based on average conditions which may not apply to a particular study area. The percentage impervious may vary greatly even on comparable sized lots due to differences in dwelling size, improvements, etc. Landscape practices should also be considered as it is common in some areas to use ornamental gravels underlain by impervious plastic materials in place of lawns and shrubs. A field investigation of a study area shall always be made, and a review of aerial photos, where available, may assist in estimating the percentage of impervious cover in developed areas.
3. For typical equestrian subdivisions increase impervious area 5 percent over the values recommended in the table above.

SAN BERNARDINO COUNTY
HYDROLOGY MANUAL

**ACTUAL IMPERVIOUS COVER
FOR
DEVELOPED AREAS**

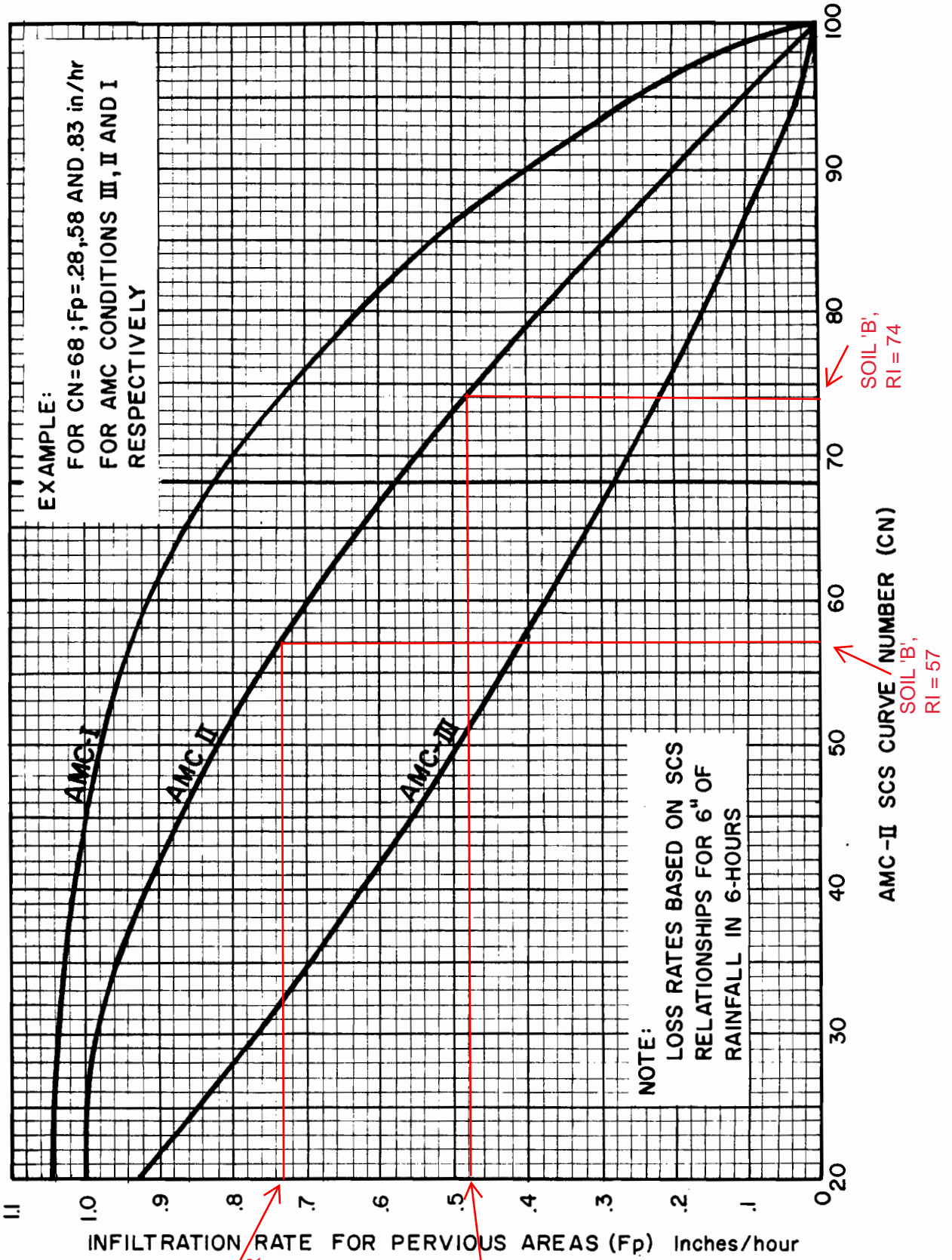

**SAN BERNARDINO COUNTY
HYDROLOGY MANUAL**

**INFILTRATION RATE FOR
PVIOUS AREAS VERSUS
SCS CURVE NUMBERS**



NOAA Atlas 14, Volume 6, Version 2
Location name: Yucca Valley, California, USA*
Latitude: 34.1228°, Longitude: -116.4527°
Elevation: 3353 ft**



* source: ESRI Maps
 ** source: USGS

POINT PRECIPITATION FREQUENCY ESTIMATES

Sanja Perica, Sarah Dietz, Sarah Heim, Lillian Hiner, Kazungu Maitaria, Deborah Martin, Sandra Pavlovic, Ishani Roy, Carl Trypaluk, Dale Unruh, Fenglin Yan, Michael Yekta, Tan Zhao, Geoffrey Bonnin, Daniel Brewer, Li-Chuan Chen, Tye Parzybok, John Yarchoan

NOAA, National Weather Service, Silver Spring, Maryland

[PF_tabular](#) | [PF_graphical](#) | [Maps_&_aerials](#)

PF tabular

PDS-based point precipitation frequency estimates with 90% confidence intervals (in inches/hour)¹										
Duration	Average recurrence interval (years)									
	1	2	5	10	25	50	100	200	500	1000
5-min	1.07 (0.888-1.31)	1.57 (1.31-1.92)	2.33 (1.92-2.86)	3.02 (2.47-3.73)	4.09 (3.24-5.22)	5.03 (3.90-6.55)	6.11 (4.62-8.15)	7.34 (5.41-10.1)	9.28 (6.55-13.3)	12.3 (8.41-18.3)
10-min	0.768 (0.636-0.936)	1.13 (0.936-1.38)	1.67 (1.37-2.05)	2.17 (1.77-2.67)	2.93 (2.32-3.74)	3.61 (2.80-4.70)	4.37 (3.31-5.84)	5.27 (3.88-7.23)	6.65 (4.70-9.52)	8.84 (6.03-13.1)
15-min	0.620 (0.512-0.756)	0.912 (0.752-1.11)	1.34 (1.11-1.65)	1.74 (1.43-2.15)	2.36 (1.87-3.02)	2.91 (2.26-3.79)	3.53 (2.67-4.71)	4.24 (3.12-5.83)	5.36 (3.79-7.67)	7.13 (4.86-10.6)
30-min	0.472 (0.390-0.576)	0.694 (0.574-0.848)	1.03 (0.846-1.26)	1.33 (1.09-1.64)	1.80 (1.43-2.30)	2.22 (1.72-2.89)	2.69 (2.03-3.59)	3.24 (2.38-4.44)	4.09 (2.89-5.85)	5.43 (3.71-8.04)
60-min	0.330 (0.273-0.403)	0.486 (0.402-0.593)	0.718 (0.592-0.879)	0.930 (0.761-1.15)	1.26 (0.998-1.61)	1.55 (1.20-2.02)	1.88 (1.42-2.51)	2.26 (1.67-3.11)	2.86 (2.02-4.09)	3.80 (2.59-5.63)
2-hr	0.230 (0.190-0.280)	0.324 (0.268-0.396)	0.461 (0.380-0.564)	0.583 (0.477-0.720)	0.767 (0.607-0.979)	0.924 (0.717-1.20)	1.10 (0.831-1.47)	1.29 (0.952-1.78)	1.59 (1.12-2.27)	1.92 (1.31-2.84)
3-hr	0.182 (0.151-0.223)	0.254 (0.210-0.310)	0.356 (0.294-0.436)	0.446 (0.365-0.551)	0.581 (0.459-0.741)	0.694 (0.538-0.904)	0.818 (0.619-1.09)	0.956 (0.703-1.31)	1.16 (0.820-1.66)	1.34 (0.913-1.98)
6-hr	0.121 (0.100-0.147)	0.166 (0.137-0.203)	0.230 (0.189-0.281)	0.285 (0.233-0.352)	0.366 (0.290-0.467)	0.433 (0.336-0.564)	0.506 (0.382-0.675)	0.585 (0.430-0.803)	0.701 (0.495-1.00)	0.798 (0.545-1.18)
12-hr	0.075 (0.062-0.091)	0.103 (0.085-0.126)	0.144 (0.118-0.176)	0.178 (0.146-0.220)	0.229 (0.181-0.292)	0.271 (0.210-0.353)	0.316 (0.239-0.422)	0.365 (0.268-0.501)	0.437 (0.308-0.625)	0.497 (0.339-0.736)
24-hr	0.047 (0.042-0.054)	0.066 (0.058-0.076)	0.093 (0.082-0.107)	0.116 (0.101-0.135)	0.150 (0.127-0.181)	0.179 (0.148-0.220)	0.210 (0.170-0.264)	0.244 (0.192-0.315)	0.294 (0.222-0.396)	0.336 (0.246-0.468)
2-day	0.026 (0.023-0.030)	0.037 (0.033-0.043)	0.053 (0.047-0.062)	0.067 (0.059-0.078)	0.088 (0.075-0.106)	0.106 (0.088-0.130)	0.125 (0.101-0.157)	0.146 (0.115-0.189)	0.177 (0.134-0.239)	0.204 (0.149-0.284)
3-day	0.019 (0.017-0.022)	0.027 (0.024-0.032)	0.040 (0.035-0.046)	0.050 (0.044-0.059)	0.066 (0.056-0.080)	0.080 (0.066-0.098)	0.095 (0.077-0.120)	0.112 (0.088-0.144)	0.136 (0.103-0.184)	0.157 (0.115-0.219)
4-day	0.015 (0.013-0.017)	0.021 (0.019-0.025)	0.031 (0.027-0.036)	0.040 (0.035-0.046)	0.053 (0.045-0.064)	0.064 (0.053-0.078)	0.076 (0.061-0.095)	0.089 (0.070-0.116)	0.109 (0.083-0.147)	0.126 (0.092-0.176)
7-day	0.009 (0.008-0.010)	0.014 (0.012-0.016)	0.020 (0.018-0.023)	0.026 (0.022-0.030)	0.034 (0.029-0.041)	0.042 (0.035-0.051)	0.050 (0.040-0.063)	0.059 (0.046-0.076)	0.072 (0.055-0.098)	0.084 (0.061-0.117)
10-day	0.007 (0.006-0.008)	0.010 (0.009-0.012)	0.015 (0.013-0.018)	0.020 (0.017-0.023)	0.026 (0.022-0.032)	0.032 (0.026-0.039)	0.038 (0.031-0.048)	0.045 (0.035-0.058)	0.055 (0.042-0.075)	0.064 (0.047-0.089)
20-day	0.004 (0.003-0.004)	0.006 (0.005-0.006)	0.008 (0.007-0.010)	0.011 (0.009-0.013)	0.014 (0.012-0.017)	0.017 (0.014-0.022)	0.021 (0.017-0.026)	0.025 (0.019-0.032)	0.030 (0.023-0.041)	0.035 (0.026-0.049)
30-day	0.003 (0.002-0.003)	0.004 (0.003-0.005)	0.006 (0.005-0.007)	0.008 (0.007-0.009)	0.011 (0.009-0.013)	0.013 (0.011-0.016)	0.015 (0.012-0.019)	0.018 (0.014-0.023)	0.022 (0.017-0.030)	0.026 (0.019-0.036)
45-day	0.002 (0.002-0.002)	0.003 (0.003-0.003)	0.005 (0.004-0.005)	0.006 (0.005-0.007)	0.008 (0.007-0.009)	0.009 (0.008-0.012)	0.011 (0.009-0.014)	0.013 (0.010-0.017)	0.016 (0.012-0.022)	0.019 (0.014-0.026)
60-day	0.002 (0.001-0.002)	0.002 (0.002-0.003)	0.004 (0.003-0.004)	0.005 (0.004-0.006)	0.006 (0.005-0.008)	0.008 (0.006-0.010)	0.009 (0.007-0.012)	0.011 (0.008-0.014)	0.013 (0.010-0.018)	0.015 (0.011-0.021)

¹ Precipitation frequency (PF) estimates in this table are based on frequency analysis of partial duration series (PDS). Numbers in parenthesis are PF estimates at lower and upper bounds of the 90% confidence interval. The probability that precipitation frequency estimates (for a given duration and average recurrence interval) will be greater than the upper bound (or less than the lower bound) is 5%. Estimates at upper bounds are not checked against probable maximum precipitation (PMP) estimates and may be higher than currently valid PMP values. Please refer to NOAA Atlas 14 document for more information.

[Back to Top](#)

PF graphical

PDS-based intensity-duration-frequency (IDF) curves

Latitude: 34.1228°, Longitude: -116.4527°

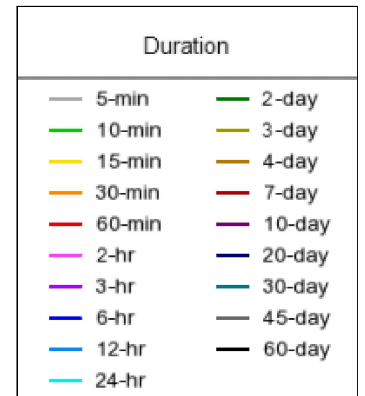
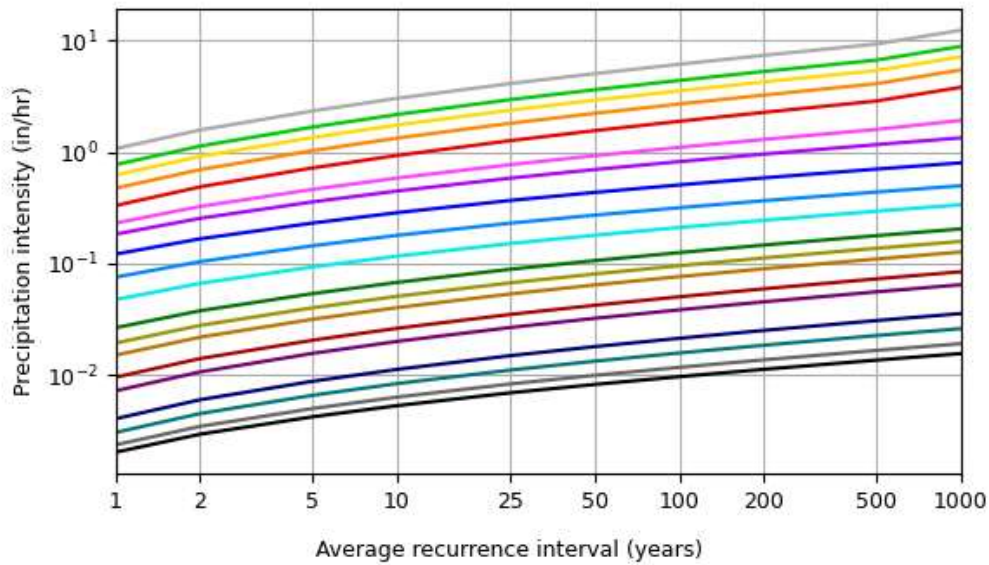
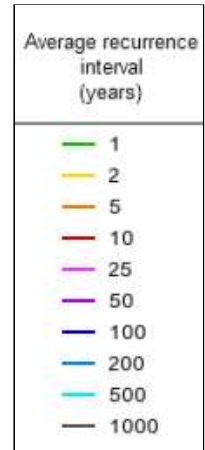
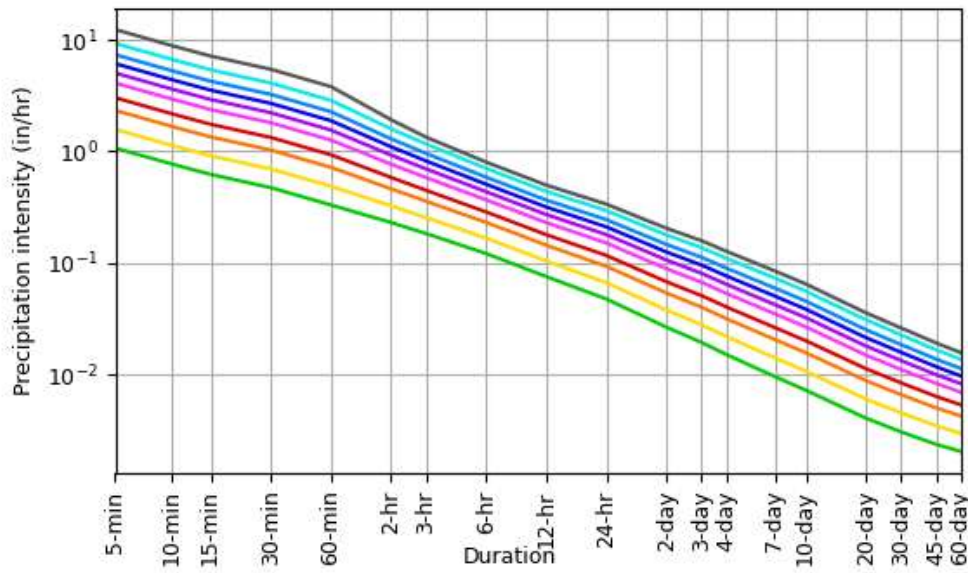

[Back to Top](#)

Maps & aeriels

Small scale terrain

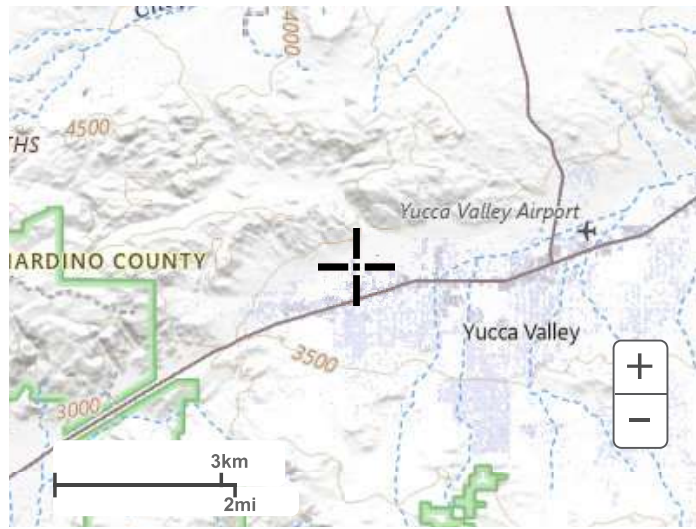

Large scale terrain



Large scale map



Large scale aerial



[Back to Top](#)

[US Department of Commerce](#)
[National Oceanic and Atmospheric Administration](#)
[National Weather Service](#)
[National Water Center](#)
1325 East West Highway
Silver Spring, MD 20910
Questions?: HDSC.Questions@noaa.gov

[Disclaimer](#)

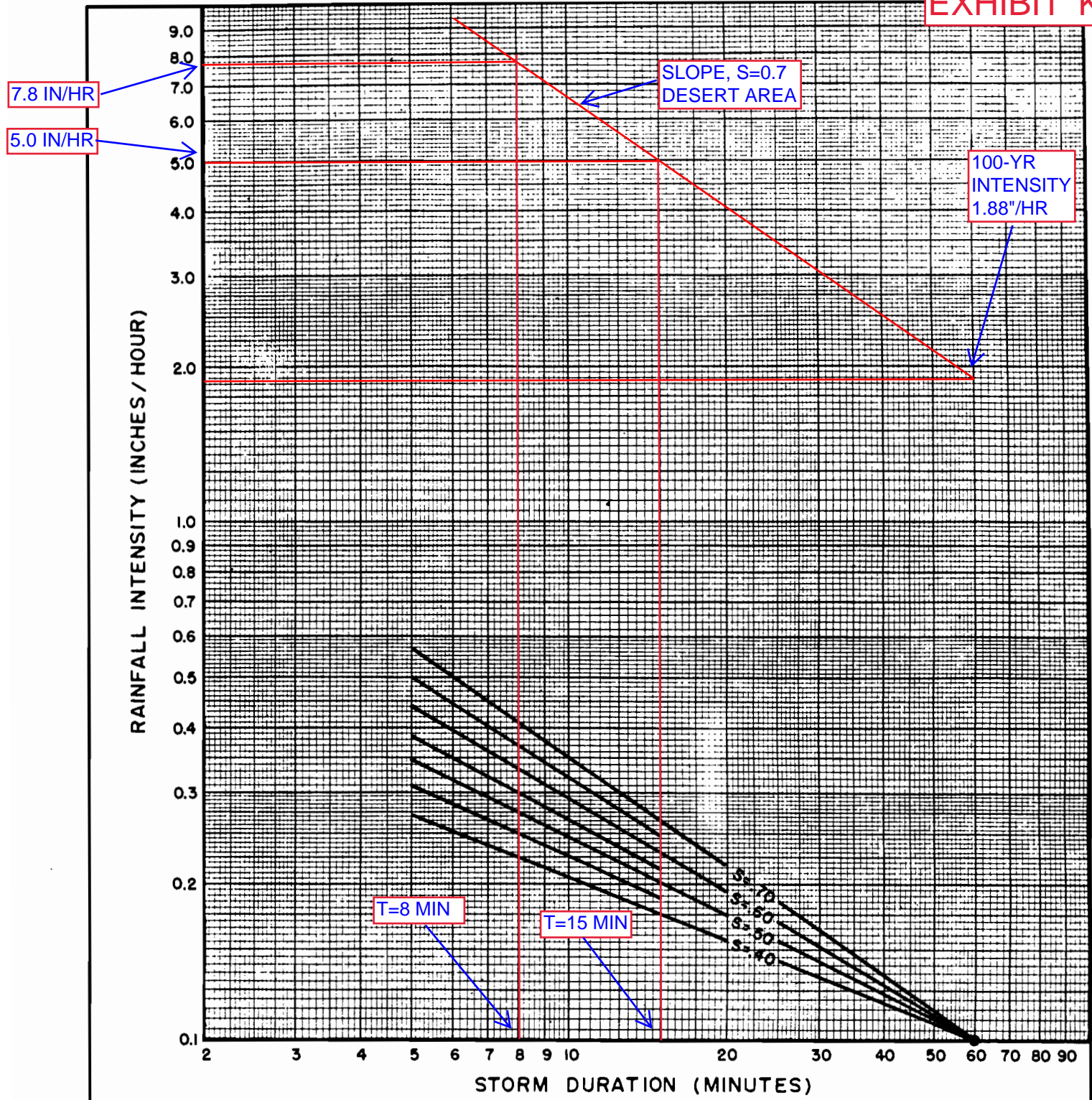

DESIGN STORM FREQUENCY = 100 YEARS
 ONE HOUR POINT RAINFALL = 1.88 INCHES
 LOG-LOG SLOPE = 0.7
 PROJECT LOCATION = SOUTHWEST-B AREA

SAN BERNARDINO COUNTY
 HYDROLOGY MANUAL

**INTENSITY - DURATION
 CURVES
 CALCULATION SHEET**

NOTES TO USERS

This map is for use in administering the National Flood Insurance Program. It does not necessarily identify all areas subject to flooding, particularly from local drainage sources of small size. The community map repository should be consulted for possible updated or additional flood hazard information.

To obtain more detailed information in areas where **Base Flood Elevations (BFEs)** and/or **floodways** have been determined, users are encouraged to consult the Flood Profiles and Floodway Data and/or Summary of Stillwater Elevations tables contained within the Flood Insurance Study (FIS) report that accompanies this FIRM. Users should be aware that BFEs shown on the FIRM represent rounded whole-foot elevations. These BFEs are intended for flood insurance rating purposes only and should not be used as the sole source of flood elevation information. Accordingly, flood elevation data presented in the FIS report should be utilized in conjunction with the FIRM for purposes of construction and/or floodplain management.

Coastal Base Flood Elevations shown on this map apply only landward of 0.0' North American Vertical Datum of 1988 (NAVD 88). Users of this FIRM should be aware that coastal flood elevations are also provided in the Summary of Stillwater Elevations tables in the Flood Insurance Study report for this jurisdiction. Elevations shown in the Summary of Stillwater Elevations tables should be used for construction and/or floodplain management purposes when they are higher than the elevations shown on this FIRM.

Boundaries of the **floodways** were computed at cross sections and interpolated between cross sections. The floodways were based on hydraulic considerations with regard to requirements of the National Flood Insurance Program. Floodway widths and other pertinent floodway data are provided in the Flood Insurance Study report for this jurisdiction.

Certain areas not in Special Flood Hazard Areas may be protected by **flood control structures**. Refer to Section 2.4 "Flood Protection Measures" of the Flood Insurance Study report for information on flood control structures for this jurisdiction.

The **projection** used in the preparation of this map was Universal Transverse Mercator (UTM) zone 11 North. The **horizontal datum** was NAD 83, GRS80 spheroid. Differences in datum, spheroid, projection or UTM zones used in the production of FIRMs for adjacent jurisdictions may result in slight positional differences in map features across jurisdiction boundaries. These differences do not affect the accuracy of this FIRM.

Flood elevations on this map are referenced to the North American Vertical Datum of 1988. These flood elevations must be compared to structure and ground elevations referenced to the same **vertical datum**. For information regarding conversion between the National Geodetic Vertical Datum of 1929 and the North American Vertical Datum of 1988, visit the National Geodetic Survey website at <http://www.ngs.noaa.gov> or contact the National Geodetic Survey at the following address:

NGS Information Services
NOAA, NNGS12
National Geodetic Survey
SSMC-3, #9202
1315 East-West Highway
Silver Spring, Maryland 20910-3282
(301) 713-3242

To obtain current elevation, description, and/or location information for **bench marks** shown on this map, please contact the Information Services Branch of the National Geodetic Survey at (301) 713-3242, or visit its website at <http://www.ngs.noaa.gov>.

Base map information shown on this FIRM was derived from digital orthophotography collected by the U.S. Department of Agriculture Farm Service Agency. This imagery was flown in 2005 and was produced with a 1-meter ground sample distance.

This map may reflect more detailed and up-to-date stream channel configurations than those shown on the previous FIRM for this jurisdiction. The floodplains and floodways that were transferred from the previous FIRM may have been adjusted to confirm to these new stream channel configurations. As a result, the Flood Profiles and Floodway Data tables in the Flood Insurance Study Report (which contains authoritative hydraulic data) may reflect stream channel distances that differ from what is shown on this map.

Corporate limits shown on this map are based on the best data available at the time of publication. Because changes due to annexations or de-annexations may have occurred after this map was published, map users should contact appropriate community officials to verify current corporate limit locations.

Please refer to the separately printed **Map Index** for an overview map of the county showing the layout of map panels, community map repository addresses, and a Listing of Communities table containing National Flood Insurance Program dates for each community as well as a listing of the panels on which each community is located.

Contact the **FEMA Map Service Center** at 1-800-358-9616 for information on available products associated with this FIRM. Available products may include previously issued Letters of Map Change, a Flood Insurance Study report, and/or digital versions of this map. The FEMA Map Service Center may also be reached by Fax at 1-800-358-9620 and its website at <http://msc.fema.gov>.

If you have **questions about this map** or questions concerning the National Flood Insurance Program in general, please call **1-877-FEMA MAP** (1-877-336-2627) or visit the FEMA website at <http://www.fema.gov>.

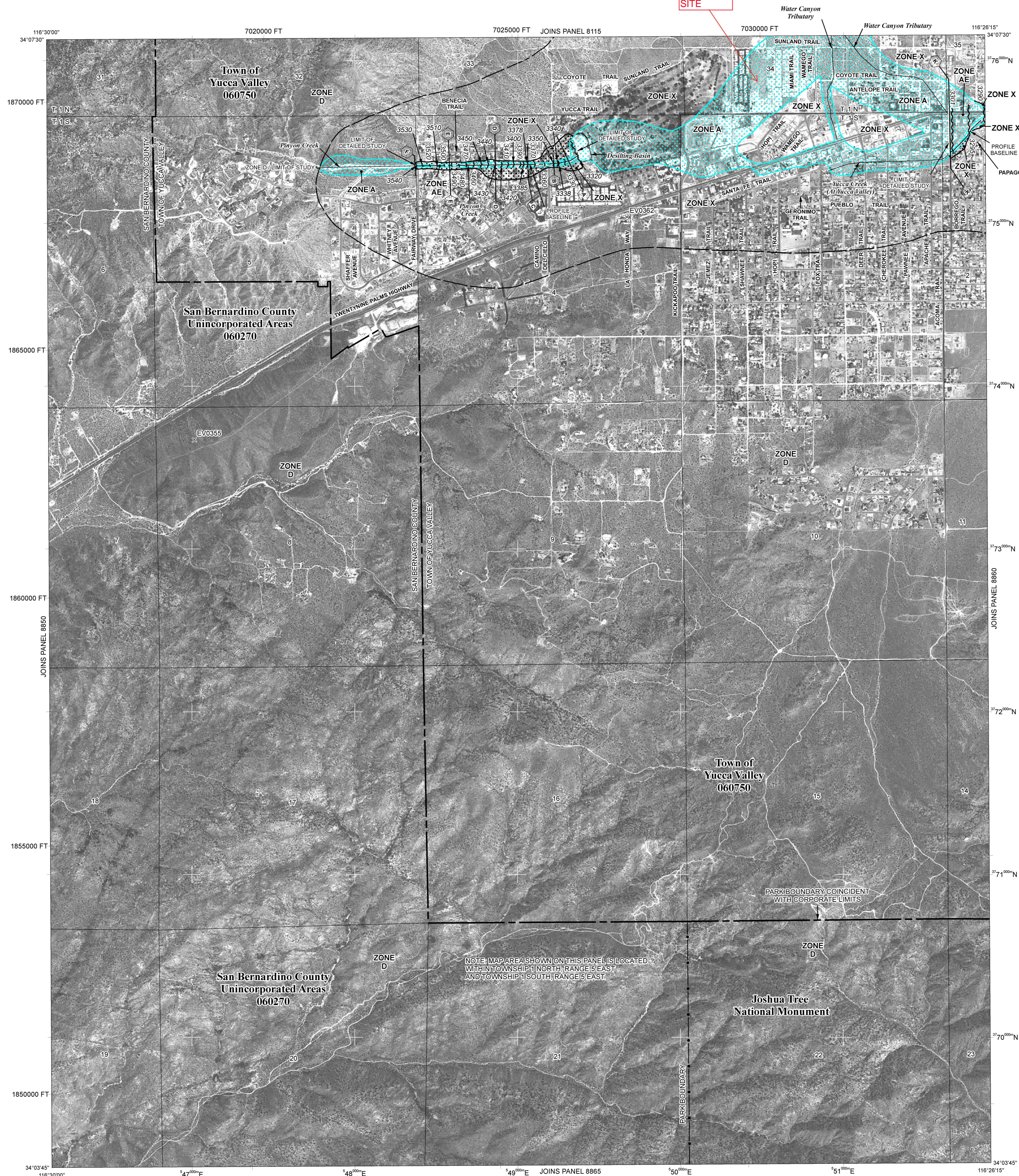

LEGEND

- SPECIAL FLOOD HAZARD AREAS SUBJECT TO INUNDATION BY THE 1% ANNUAL CHANCE FLOOD
- The 1% annual flood (100-year flood), also known as the base flood, is the flood that has a 1% chance of being equaled or exceeded in any given year. The Special Flood Hazard Area is the area subject to flooding by the 1% annual chance flood. Areas of Special Flood Hazard include Zones A, AE, AH, AO, AR, A99, V, and VE. The Base Flood Elevation is the water-surface elevation of the 1% annual chance flood.
- ZONE A**
No Base Flood Elevations determined.
- ZONE AE**
Base Flood Elevations determined.
- ZONE AH**
Flood depths of 1 to 3 feet (usually areas of ponding); Base Flood Elevations determined.
- ZONE AO**
Flood depths of 1 to 3 feet (usually sheet flow on sloping terrain); average depths determined. For areas of alluvial fan flooding, velocities also determined.
- ZONE AR**
Special Flood Hazard Area formerly protected from the 1% annual chance flood by a flood control system that was subsequently identified. Zone AR indicates that the former flood control system is being restored to provide protection from the 1% annual chance or greater flood.
- ZONE A99**
Area to be protected from 1% annual chance flood by a Federal flood protection system under construction; no Base Flood Elevations determined.
- ZONE V**
Coastal flood zone with velocity hazard (wave action); no Base Flood Elevations determined.
- ZONE VE**
Coastal flood zone with velocity hazard (wave action); Base Flood Elevations determined.
- FLOODWAY AREAS IN ZONE AE
- The floodway is the channel of a stream plus any adjacent floodplain areas that must be kept free of encroachment so that the 1% annual chance flood can be carried without substantial increases in flood heights.
- OTHER FLOOD AREAS
- ZONE X**
Areas of 0.2% annual chance flood; areas of 1% annual chance flood with average depths of less than 1 foot or with drainage areas less than 1 square mile, and areas protected by levees from 1% annual chance flood.
- OTHER AREAS
- ZONE X**
Areas determined to be outside the 0.2% annual chance floodplain.
- ZONE D**
Areas in which flood hazards are undetermined, but possible.
- COASTAL BARRIER RESOURCES SYSTEM (CBRS) AREAS
- OTHERWISE PROTECTED AREAS (OPAs)
- CBRS areas and OPAs are normally located within or adjacent to Special Flood Hazard Areas.
- 1% annual chance floodplain boundary
- 0.2% annual chance floodplain boundary
- Floodway boundary
- Zone D boundary
- CBRS and OPA boundary
- Boundary dividing Special Flood Hazard Area Zones and boundary dividing Special Flood Hazard Areas of different Base Flood Elevations, flood depths or flood velocities.
- Base Flood Elevation line and value; elevation in feet* (EL 987)
- Base Flood Elevation value where uniform within zone; elevation in feet*
- * Referenced to the North American Vertical Datum of 1988
- Cross section line
- Transect line
- Geographic coordinates referenced to the North American Datum of 1983 (NAD 83), Western Hemisphere
- 1000-meter Universal Transverse Mercator grid values, zone 11N
- 600000 FT
5000-foot grid ticks; California State Plane coordinate system, zone V (FIPSZONE 0405), Lambert Conformal Conic projection
- DX5510 x
Bench mark (see explanation in Notes to Users section of this FIRM panel)
- M1.5
River Mile
- MAP REPOSITORY
Refer to listing of Map Repositories on Map Index
- EFFECTIVE DATE OF COUNTYWIDE FLOOD INSURANCE RATE MAP
March 18, 1998
- EFFECTIVE DATE(S) OF REVISION(S) TO THIS PANEL
August 28, 2008 - to update corporate limits, to change Base Flood Elevations and Special Flood Hazard Areas, to update map format, to add roads and road names, and to incorporate previously issued Letters of Map Revision.

For community map revision history prior to countywide mapping, refer to the Community Map History table located in the Flood Insurance Study report for this jurisdiction.

To determine if flood insurance is available in this community, contact your Insurance agent or call the National Flood Insurance Program at 1-800-538-6620.

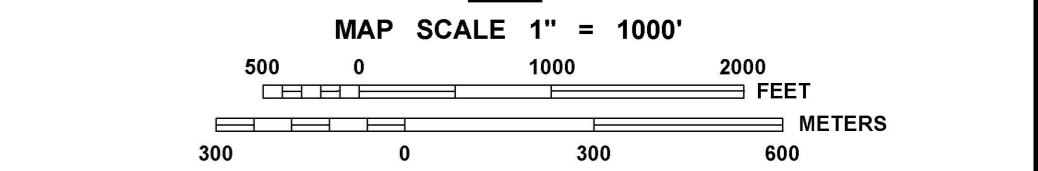

NATIONAL FLOOD INSURANCE PROGRAM

PANEL 8855H

FIRM
FLOOD INSURANCE RATE MAP

SAN BERNARDINO COUNTY, CALIFORNIA AND INCORPORATED AREAS
PANEL 8855 OF 9400
(SEE MAP INDEX FOR FIRM PANEL LAYOUT)

CONTAINS:

COMMUNITY	NUMBER	PANEL	SUFFIX
SAN BERNARDINO COUNTY	060270	8855	H
YUCCA VALLEY, TOWN OF	060750	8855	H

Notice to User: The Map Number shown below should be used when placing map orders; the Community Number shown above should be used on insurance applications for the subject community.

MAP NUMBER
06071C8855H

MAP REVISED
AUGUST 28, 2008

Federal Emergency Management Agency