

Section 4 – Storm Drain and Drainage Details

<u>Drawing No.</u>	<u>Description</u>
400	Local Depression
401	Local Depression
402	Local Depression No. 2
403	Local Depression No. 3
404	Curb Outlet Structure
405	Outlet Structure
406	Parkway Culvert with Steel Pate Cover
410	Junction Structure No. 1
411	Junction Structure No. 2
411A	Junction Structure No. 2
412	Junction Structure No. 3
413	Junction Structure No. 4
414	Junction Structure No. 5
415	Junction Structure No. 6
416	Junction Structure No. 7
420	Transition Structure No. 1
421	Transition Structure No. 2
422	Transition Structure No. 3
423	Transition Structure No. 4
430	Connector Pipe Collar
431	Concrete Collar for Pipe 12 Inches Through 66 Inches
440	Headwall Wing – Type
441	Headwall “U” – Type
450	Cutoff Wall for Drainage Channel
451	Channel Crossing
460	Inlet Type X (Grate Details)
461	Inlet Type IX (Checkered Plate
462	Storm Drain Cleanout
463	Standard Dry Well
464	Timber Bulkheads
465	Timber Bulkheads
466	Concrete Bulkheads
467	Pipe Supports Across Trenches
468	Bedding and Pay Lines
470	Catch Basin No. 1
471	Catch Basin No. 4 (Sht. 1 of 2)
471A	Catch Basin No. 4 (Sht. 2 of 2)

<u>Drawing No.</u>	<u>Description</u>
472	Catch Basin No. 6
473	Catch Basin Reinforcement
474	Special Connections to Catch Basin
475	Type "A" Catch Basin
476	Catch Basin Mountain Roads
476A	Catch Basin Mountain Roads
477	Catch Basin Grate
480	Catch Basin Opening
480A	Catch Basin Steel Plate Galvanized Steel Step
481	Removable Protection Bar for Catch Basins
481A	Detail of Catch Basin Opening & Installation Details
482	Standard Drop Step
483	Manhole Frame & Cover for Catch Basins
490	Storm Drain Manhole No. 1 (Sht. 1 of 2)
490A	Storm Drain Manhole No. 1 (Sht. 2 of 2)
491	Storm Drain Manhole No. 2
492	Storm Drain Manhole No. 3
493	Storm Drain Manhole No. 4
493A	Storm Drain Manhole No. 4
494	Manhole Shaft for Cast Pipe
495	Standard Pressure Manhole Shaft
496	Manhole Frame & Cover – Roadway
497	Manhole Frame & Cover – Parkway
498	Manhole Frame & Cover – Non-Rocking
499	Manhole Frame & Cover – Pressure Type

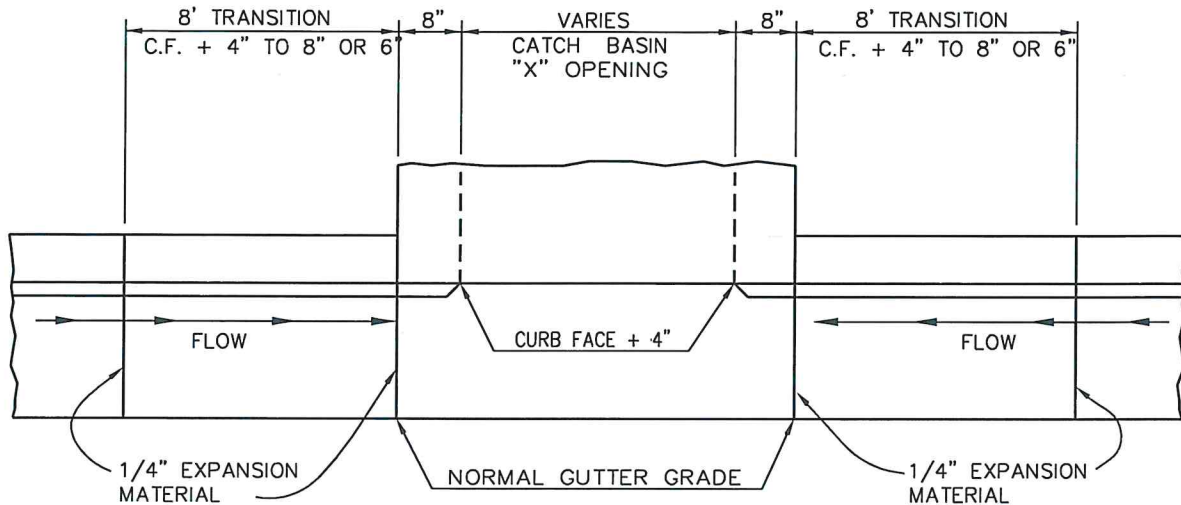

NOTES:

1. LOCAL DEPRESSION SHALL BE CONSTRUCTED OF CLASS "B" CONCRETE 6" THICK
2. CURB AND GUTTER SHALL BE CONSTRUCTED PRIOR TO CONSTRUCTING TOP OF CATCH BASIN AND CURB TRANSITIONS.



APPROVED: DIRECTOR OF PUBLIC WORKS

Alex Gishke DATE 4/21/25

APPROVED: TOWN ENGINEER

Noel Owsley R.C.E. 39827



Town of
Yucca Valley

▲ REVISED CURB DEPRESSION NOTE	-N-	8/30/24
REVISION	BY	DATE

LOCAL DEPRESSION

STANDARD DRAWING NO. 400

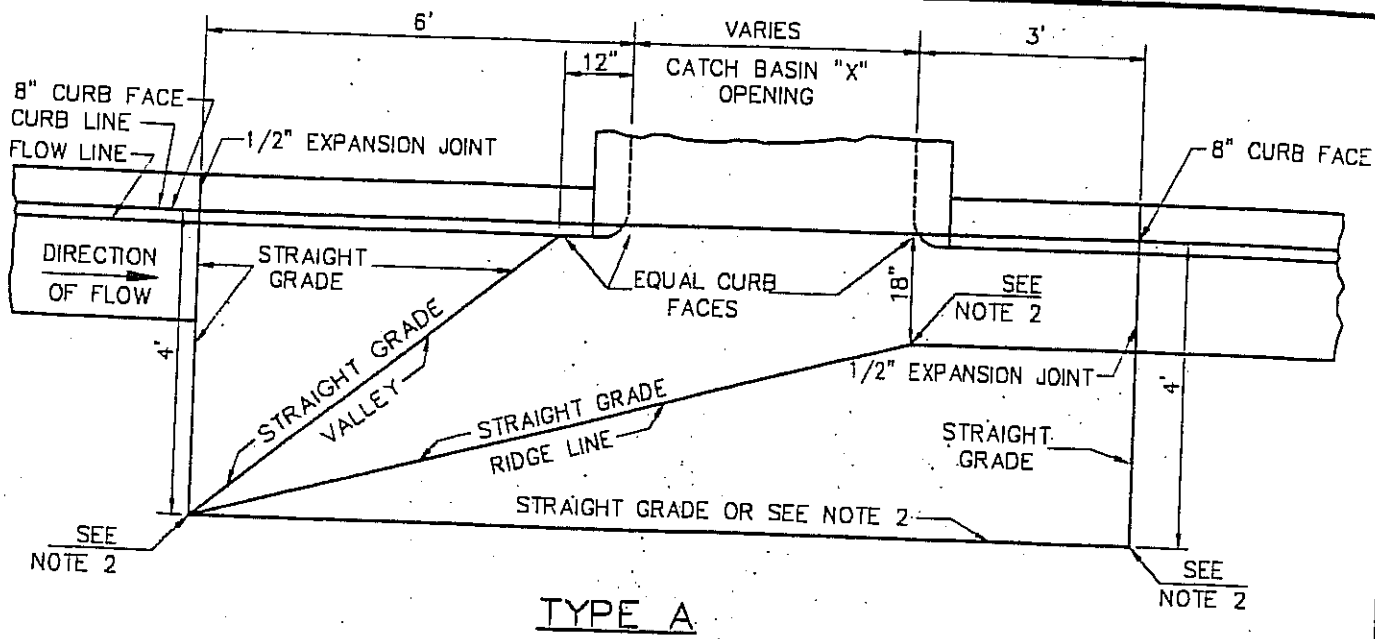

TYPE A

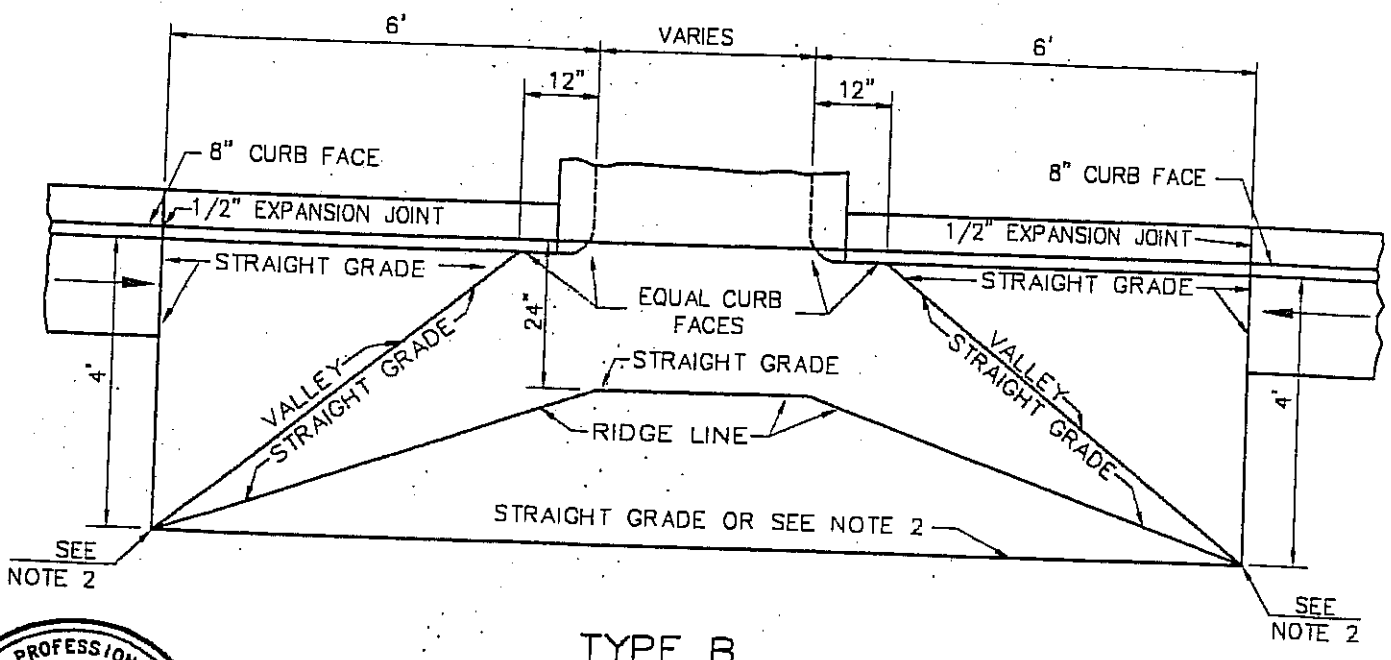

TYPE B

NOTES:

1. LOCAL DEPRESSION SHALL BE CONSTRUCTED OF CLASS "B" CONCRETE 8" THICK.
2. ELEVATIONS SHALL BE SHOWN ON CONSTRUCTION PLANS. THE OUTER EDGE OF THE LOCAL DEPRESSION SHALL CONFORM TO FINISHED STREET GRADE.
3. SPECIAL DETAILS GOVERNING THE CONSTRUCTION ON A VERTICAL CURVE SHALL BE SHOWN ON CONSTRUCTION PLANS.

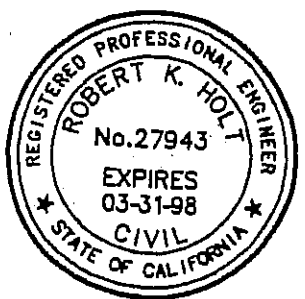

APPROVED: _____ DATE _____

APPROVED: TOWN ENGINEER
Robert K. Holt R.C.E. 27943



Town of
Yucca Valley

LOCAL DEPRESSION

STANDARD DRAWING NO. 401

REVISION	BY	DATE

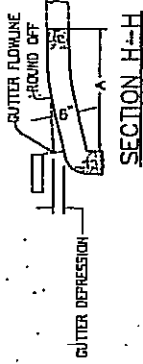
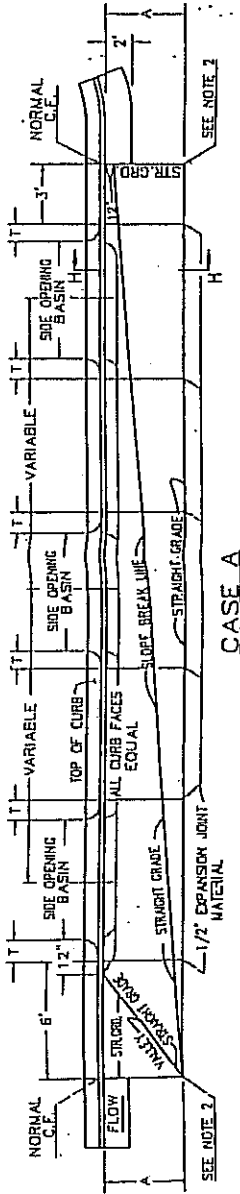

NOTES:

1. LOCAL DEPRESSION SHALL BE CASE B UNLESS OTHERWISE SPECIFIED ON GENERAL PLAN.
2. ELEVATIONS AT OUTER CORNERS SHOWN ON GENERAL PLAN IF NO ELEVATIONS ARE SPECIFIED, THE OUTER EDGE OF THE LOCAL DEPRESSION SHALL CONFORM TO FINISHED STREET SURFACE.
3. A=4 FEET UNLESS OTHERWISE SPECIFIED.
T=SEE STANDARD DRAWING 471 OR 472.
W=SEE STANDARD DRAWING 471 OR 472.
4. WHERE NO CURB EXISTS, CURB SHALL BE CONSTRUCTED BETWEEN ENDS OF LOCAL DEPRESSION. CURB SECTION SHALL CONFORM TO TOWN OF YUCCA VALLEY STANDARD DWGS.
5. DEPRESSION SHALL BE CLASS "B" CONCRETE.

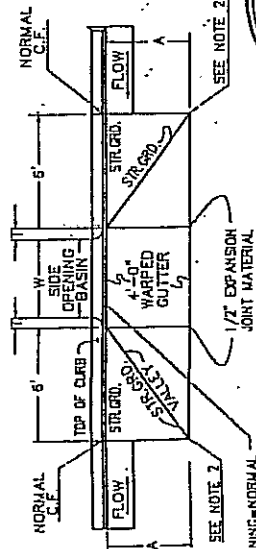
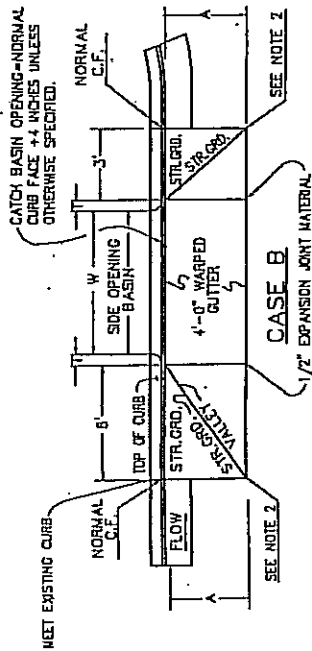

CATCH BASIN OPENING-NORMAL CURB FACE +-4 INCHES UNLESS OTHERWISE SPECIFIED.

APPROVED:	DATE
APPROVED: TOWN ENGINEER <i>Robert K. Holt</i>	DATE
R.C.E. 27943	
SECTION	BY DATE

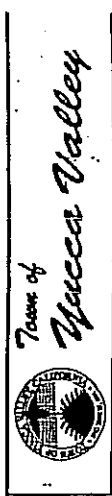

LOCAL DEPRESSION
NO. 2

STANDARD DRAWING NO. 402

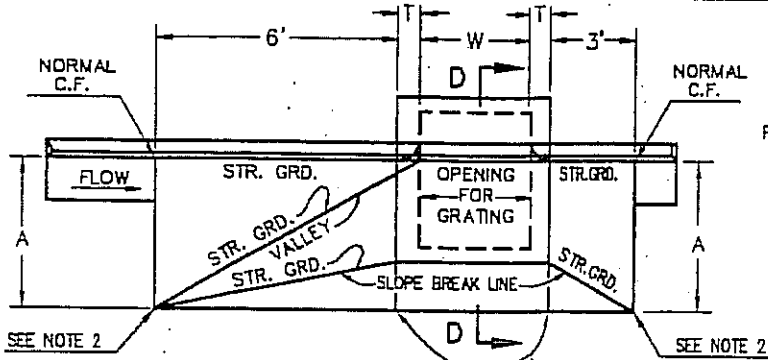

CASE A

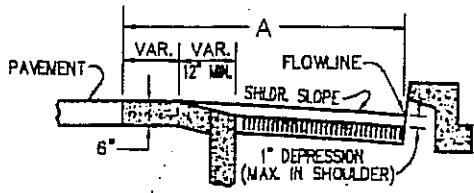

SECTION D-D

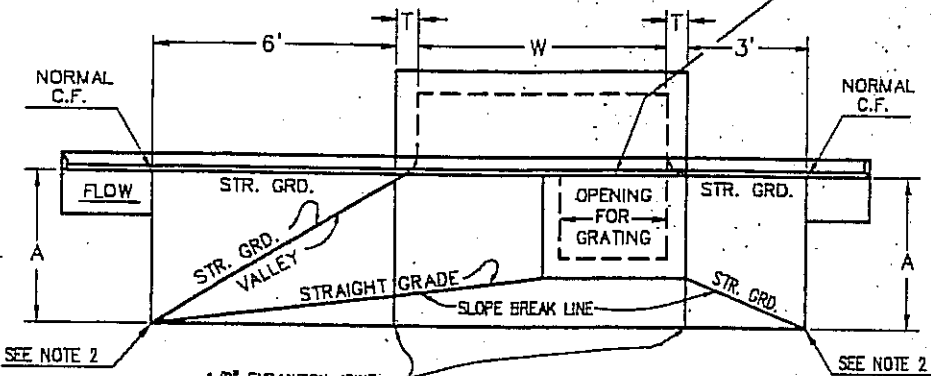

CASE B

CATCH BASIN OPENING =
NORMAL CURB FACE + 4 INCHES
UNLESS OTHERWISE SPECIFIED.

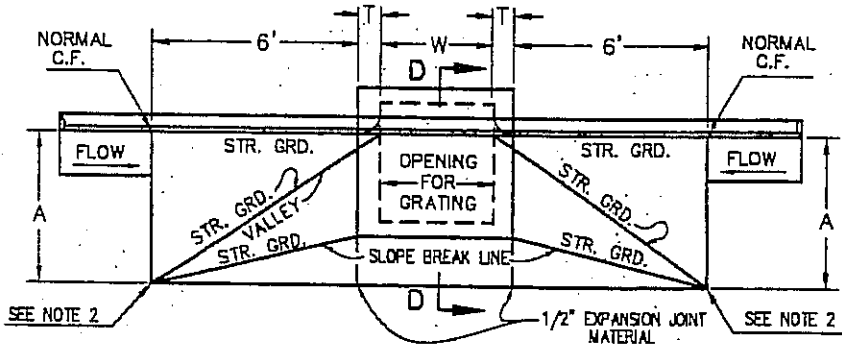

CASE C

NOTES:

1. LOCAL DEPRESSION SHALL BE:
 - (a) CASE "A" FOR CATCH BASIN NO. 4 (SEE STD. DWG. 471) UNLESS OTHERWISE SPECIFIED.
 - (b) CASE "B" FOR CATCH BASIN NO. 6 (SEE STD. DWG. 472) UNLESS OTHERWISE SPECIFIED.
2. ELEVATIONS AT OUTER CORNERS SHOWN ON PROJECT DRAWINGS. IF NO ELEVATIONS ARE SPECIFIED THE OUTER EDGE OF THE LOCAL DEPRESSION SHALL CONFORM TO THE FINISHED STREET SURFACE.
3. A=4 FEET UNLESS OTHERWISE SPECIFIED.
T=SEE STANDARD DRAWING 471 OR 472.
W=SEE STANDARD DRAWING 471 OR 472.
4. WHERE NO CURB EXISTS, CURB SHALL BE CONSTRUCTED BETWEEN ENDS OF LOCAL DEPRESSION. CURB SECTION SHALL CONFORM TO TOWN OF YUCCA VALLEY STANDARD DWGS.
5. DEPRESSION SHALL BE CLASS "B" CONCRETE.

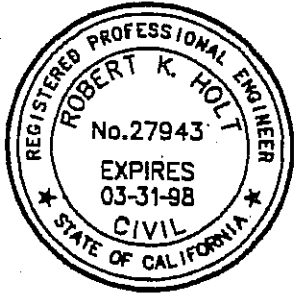

APPROVED: _____ DATE _____

APPROVED: TOWN ENGINEER
Robert K. Holt R.C.E. 27943



Town of
Yucca Valley

LOCAL DEPRESSION
NO. 3

STANDARD DRAWING NO. 403

REVISION BY DATE

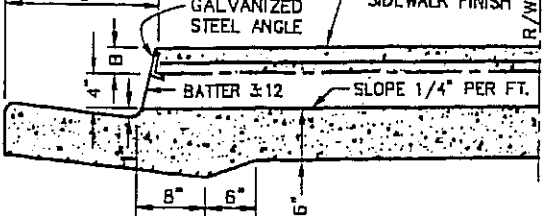

RECTANGULAR FRAME & COVER - ALHAMBRA FOUNDRY A-1402 OR EQUAL.

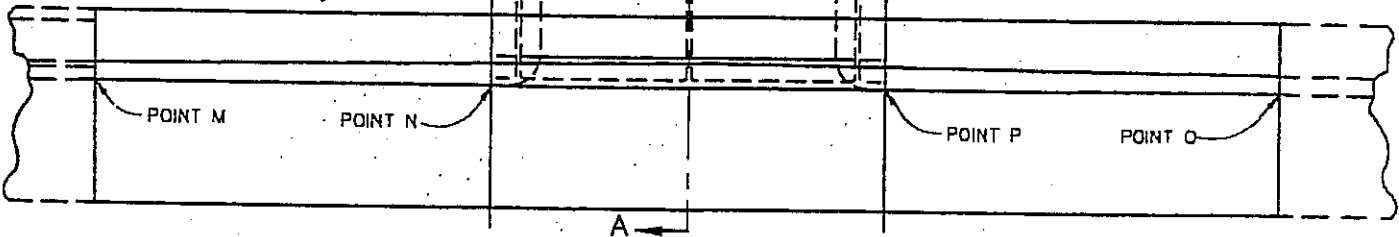
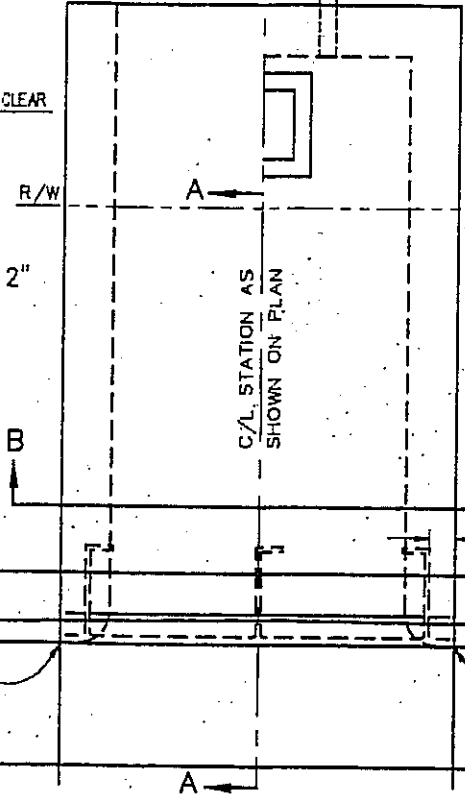
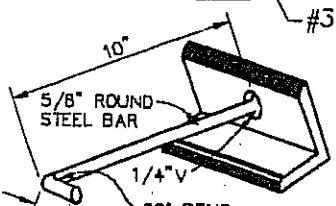
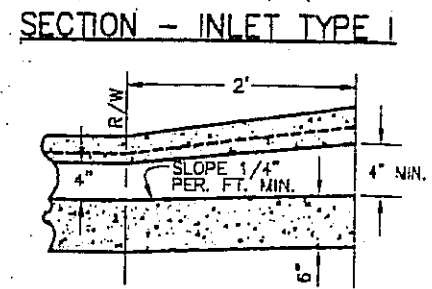
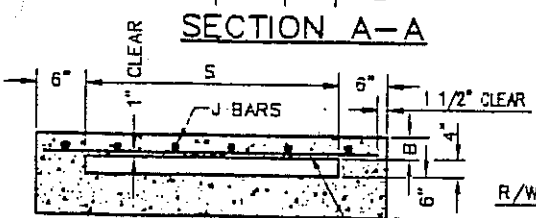
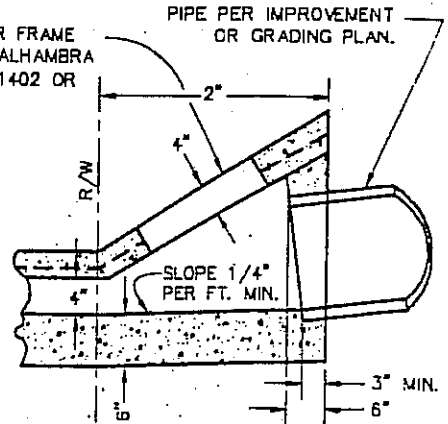

NOTES:

1. FLOOR OF BOX TO BE TROWELED SMOOTH.
2. WHEN TOE OF SLOPE IS WITHIN THE R/W, INLET TYPE I BEGINS AT THE TOE, RATHER THAN AT THE R/W LINE.
3. FOR OPEN DITCH APPROACH (TYPE II) THE 2' OR MORE IS FROM THE R/W LINE.
4. TOP OF INLET STRUCTURE (TYPE I OR II) TO BE FLUSH WITH ADJACENT SIDEWALK WHERE PRACTICAL.
5. A HEADED STEEL STUD 5/8" X 6 3/8" WITH HEAD 0.1" ATTACHED BY A FULL PENETRATION BUTT WELD MAY BE USED AS AN ALTERNATE ANCHOR.
6. NORMAL CURB AT POINTS M AND O. B + 5" AT POINTS N AND P.
7. THE 3" LEG OF THE INTERIOR ANCHORS SHALL BE PARALLEL TO THE TOP OF SIDEWALK.

S	B	GALVANIZED STEEL ANGLE	ANCHOR SIZE	J BARS		
				SIZE	SPACING	LENGTH
1'-0"	3"	2 1/2" X 2" X 3/8"	2	#3	7"	1'-9"
1'-6"	"	"	"	"	"	2'-3"
2'-0"	"	"	"	"	"	2'-6"
2'-6"	"	"	"	"	"	3'-3"
3'-0"	"	"	3	"	"	3'-9"
3'-6"	"	"	"	"	8"	4'-3"
4'-0"	"	"	"	"	5"	4'-9"
4'-6"	4"	3 1/2" X 3" X 1/2"	"	"	6 1/2"	5'-3"
5'-0"	"	"	"	"	5"	5'-9"
5'-6"	"	"	"	"	4"	6'-3"
6'-0"	"	"	"	"	3 1/2"	6'-9"

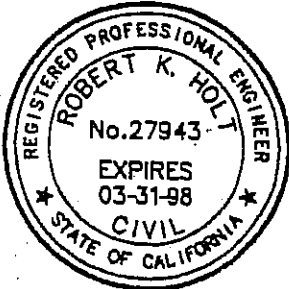

APPROVED: _____ DATE _____

APPROVED: TOWN ENGINEER
Robert K. Holt

R.C.E. 27943

REVISION	BY	DATE



Town of
Yucca Valley

CURB OUTLET STRUCTURE

STANDARD DRAWING NO. 404

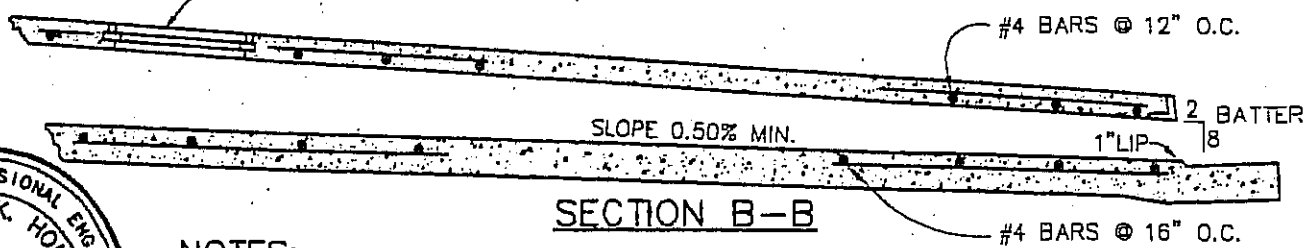
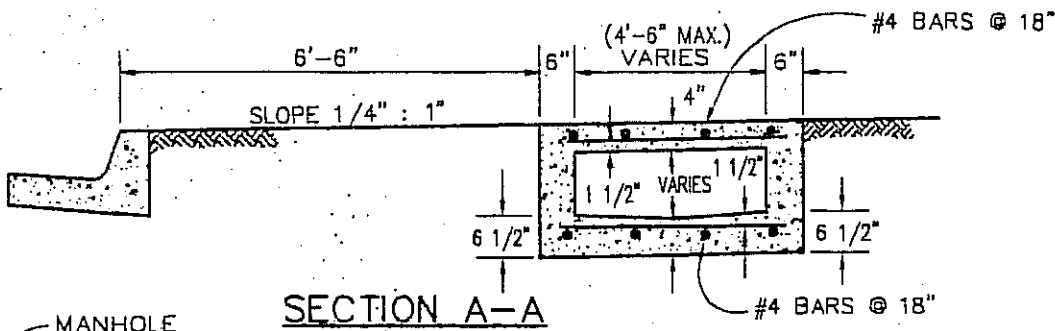
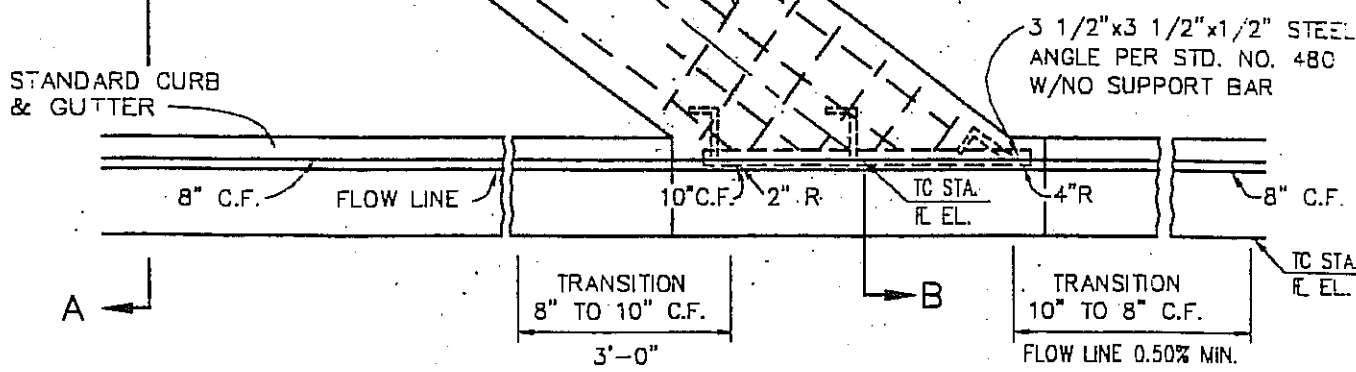
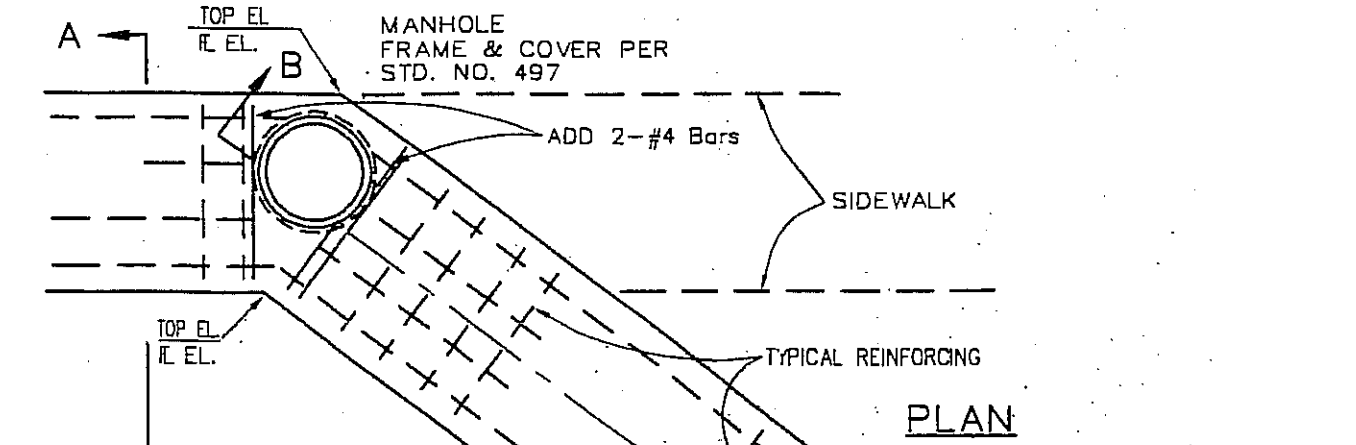

- NOTES:**
1. CONCRETE SHALL BE CLASS "A"
 2. FLOOR OF STRUCTURE SHALL BE GIVEN A STEEL TROWEL FINISH.
 3. TOP OF BOX TO HAVE SIDEWALK FINISH.
 4. ANCHORS SHALL BE SYMMETRICALLY SPACED AND NOT TO EXCEED 4' BETWEEN CENTERS, AND BE PLACED 4 1/2" FROM EACH END OF THE STEEL ANGLE, A MINIMUM OF 3 ANCHORS IS REQUIRED.

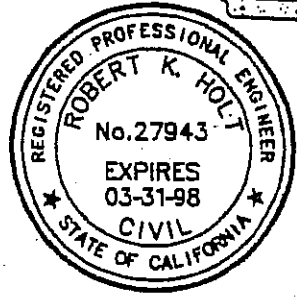

APPROVED: _____ DATE _____

APPROVED: TOWN ENGINEER
Robert K. Holt R.C.E. 27943



OUTLET STRUCTURE

STANDARD DRAWING NO. 405

REVISION	BY	DATE

2x2x3/8" WITH 3/16" WELD TO FACE OF ANGLE ONLY

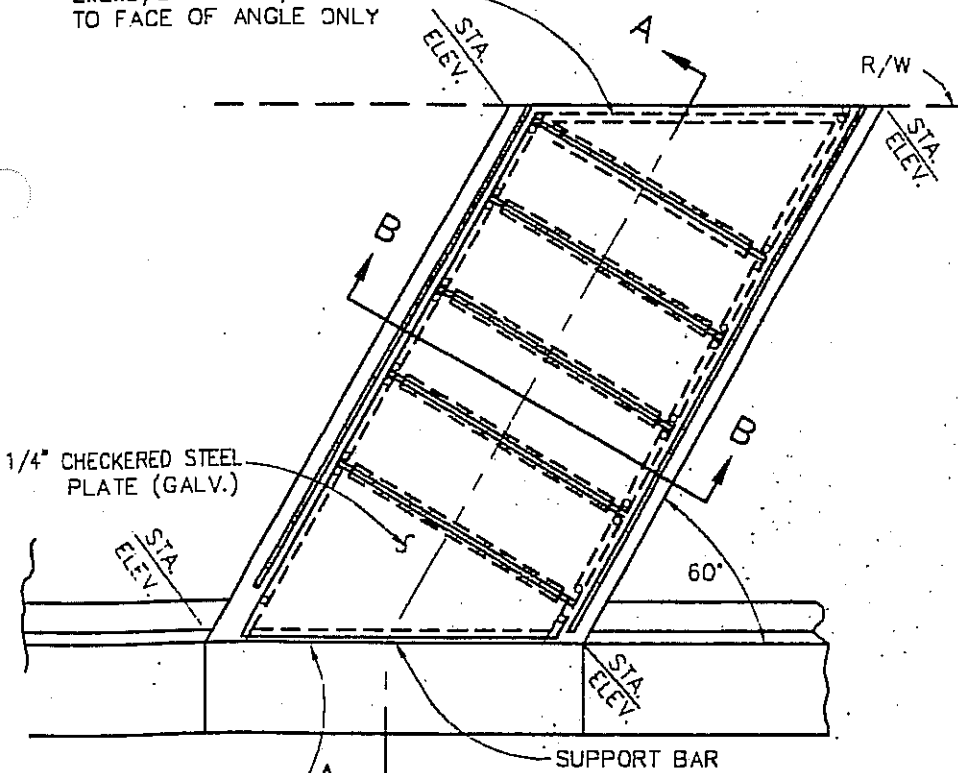

1/4" CHECKERED STEEL PLATE (GALV.)

2x2x3/8" WITH 3/16" WELD TO FACE OF ANGLE ONLY

PLAN

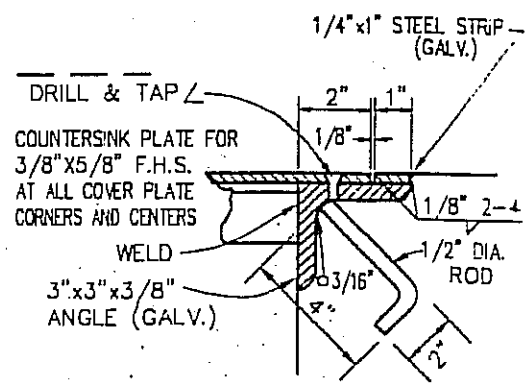

DRILL & TAP
COUNTERSINK PLATE FOR 3/8" X 5/8" F.H.S. AT ALL COVER PLATE CORNERS AND CENTERS
WELD
3" X 3" X 3/8" ANGLE (GALV.)

DETAIL B

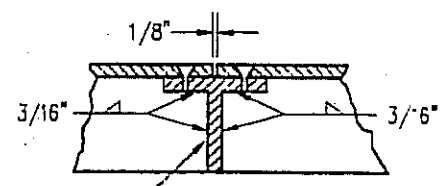

2x2x5/16" T SUPPORT

DETAIL C

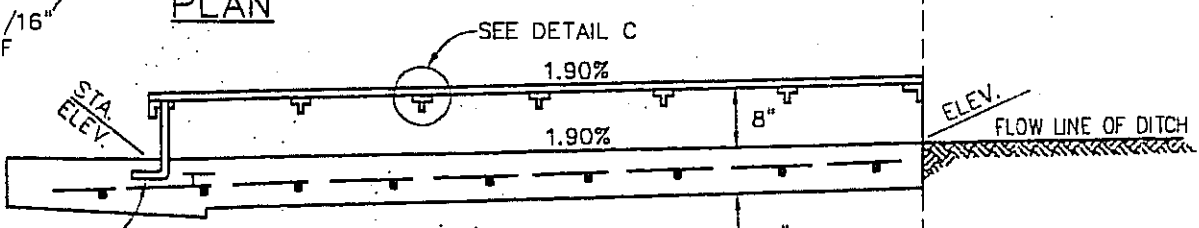

SECTION A-A

SUPPORT BAR 12" x 1/2" DIA. ROD WELD TO ANGLE

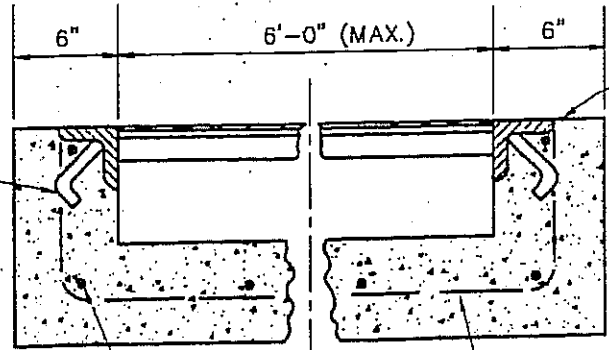

SECTION B-B

1/2" x 6" ANCHOR BAR 12" O.C.

#4 BARS 18" O.C.

#4 BARS 12" O.C.

NOTES:

1. ALL CONCRETE TO BE CLASS "A"
2. ALL STEEL EXCEPT REINFORCING BARS SHALL BE GALVANIZED AFTER FABRICATION.

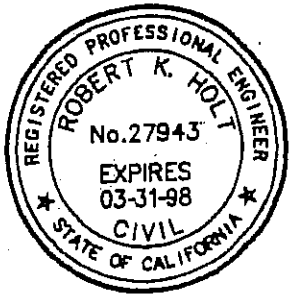

APPROVED: _____ DATE _____

APPROVED: TOWN ENGINEER
Robert K. Holt R.C.E. 27943



Town of
Yucca Valley

PARKWAY CULVERT
W/STEEL PLATE COVER

STANDARD DRAWING NO. 406

REVISION	BY	DATE

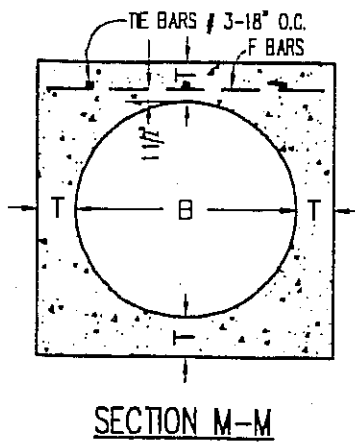
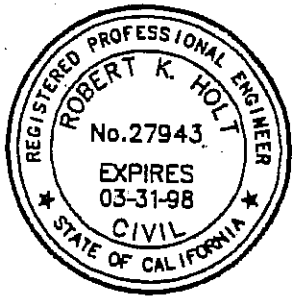
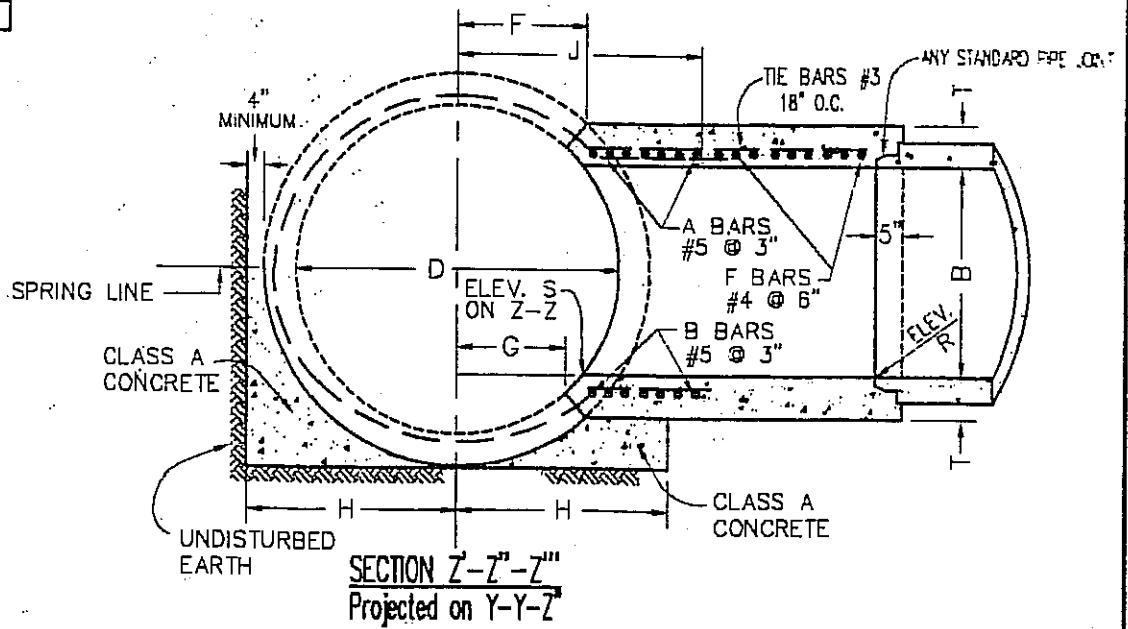
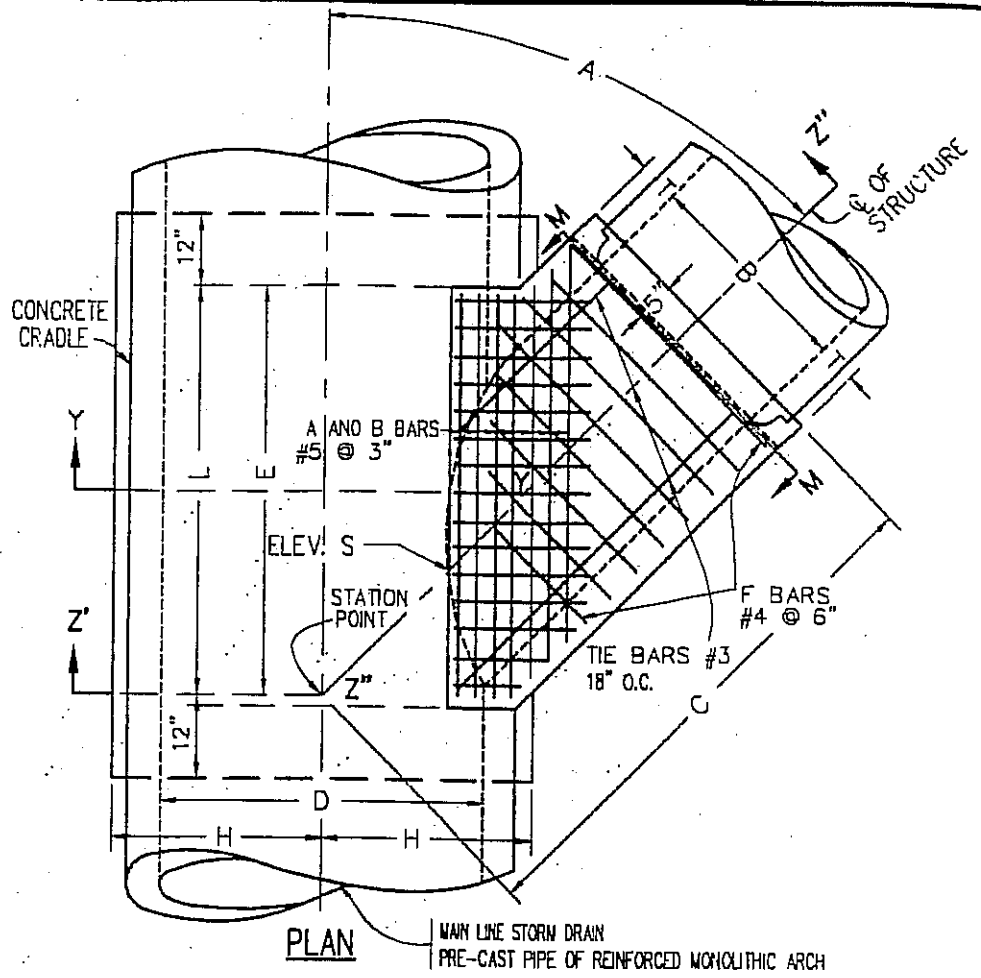

TABLE OF VALUES FOR T

B	T
12"	4"
15"	4 1/4"
18"	4 1/2"
21"	5"
24"	5 1/4"
27"	5 1/2"
30"	6"
33"	6 1/4"
36"	6 1/2"
39"	7"



APPROVED: _____ DATE _____

APPROVED: TOWN ENGINEER
Robert K. Holt R.C.E. 27943

REVISION	BY	DATE



Town of
Yucca Valley

JUNCTION STRUCTURE
 NO. 2

STANDARD DRAWING NO. 411

NOTES FOR JUNCTION STRUCTURE NO. 2

1. VALUES FOR A, B, C, D, E, F, G, L, ELEVATION R, AND ELEVATION S. SHOWN ON IMPROVEMENT PLAN.
2. PIPE SHALL BE CRADLED IN CLASS A CONCRETE EXTENDING LONGITUDINALLY TO POINTS 1 FT. BEYOND THE LIMITS OF L. $H=1/2$ OUTSIDE DIAMETER OF PIPE + 4" AS A MINIMUM. CRADLE MAY BE OMITTED ON SIDE OPPOSITE LATERAL INLET WHEN CONSTRUCTED IN CONNECTION WITH EXISTING STORM DRAIN.
3. A AND B BARS SHALL BE CARRIED TO POINT NOT LESS THAN J DISTANCE FROM CENTERLINE, $J=\frac{7D}{12}+6"$.
4. RECTANGULAR OPENING IN MAIN LINE PIPE SHALL BE CUT WITHIN THESE LIMITS NORMAL TO PIPE SURFACE WITHOUT DAMAGING STEEL. VALUES FOR F, G, AND L ON IMPROVEMENT PLAN.
5. TRANSVERSE REINFORCEMENT IN PIPE SHALL BE CUT IN CENTER OF OPENING AND BENT TO UNIFORM DISTANCE FROM TOP AND BOTTOM OF JUNCTION STRUCTURE.
6. STRUCTURAL CONCRETE SHALL BE CLASS "A".
7. REINFORCING STEEL SHALL BE ROUND, DEFORMED, STRAIGHT BARS, 1-1/2" CLEAR FROM INSIDE FACE OF CONCRETE UNLESS OTHERWISE SHOWN.
8. STEEL SCHEDULE AS SHOWN.
9. MONOLITHIC ARCH: WHEN JUNCTION STRUCTURE NO. 2 IS SPECIFIED WITH REINFORCED MONOLITHIC ARCH STORM DRAIN, VALUE D SHALL REFER TO THE CLEAR SPAN OF THE ARCH. REINFORCING STEEL SHALL BE CUT AND BENT INTO JUNCTION STRUCTURE THE SAME AS FOR PIPE. CONCRETE CRADLE UNDER REINFORCED MONOLITHIC ARCH IS NOT REQUIRED.
10. FLOOR OF STRUCTURE SHALL BE STEEL-TROWELED TO SPRING LINE.

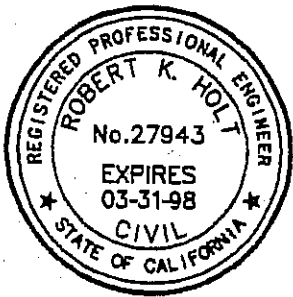

APPROVED:

DATE _____

APPROVED: TOWN ENGINEER

Robert K. Holt

R.C.E. 27943



Town of
Yucca Valley

JUNCTION STRUCTURE
NO. 2

REVISION

BY DATE

STANDARD DRAWING NO. 411A

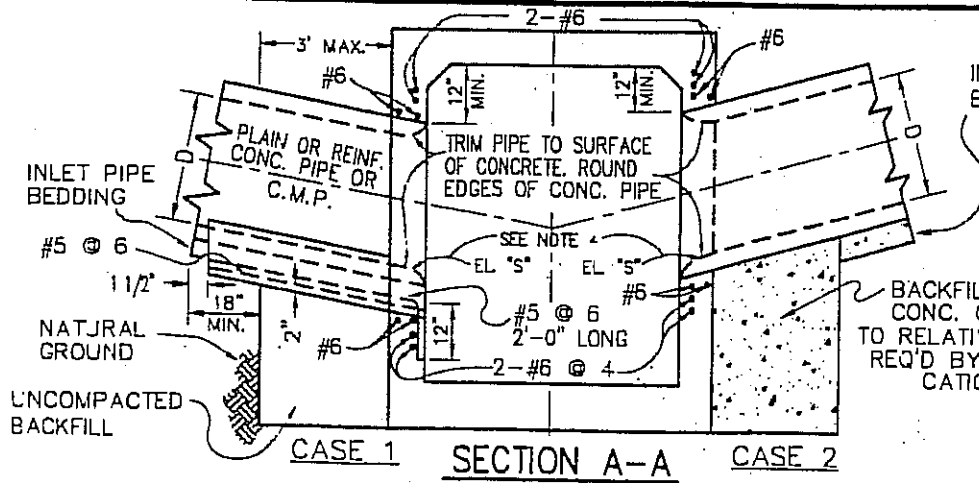

INLET PIPE BEDDING

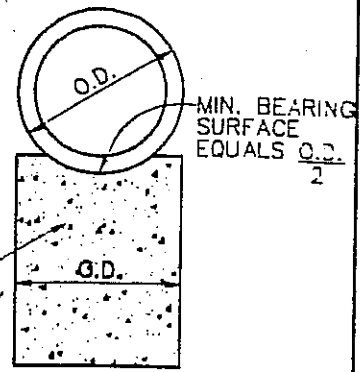

SECTION B-B

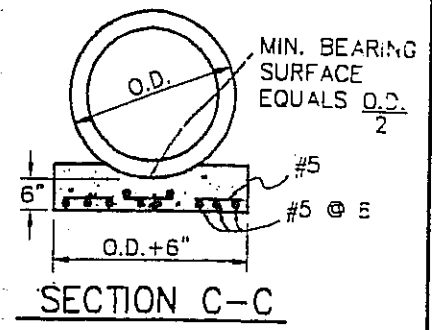
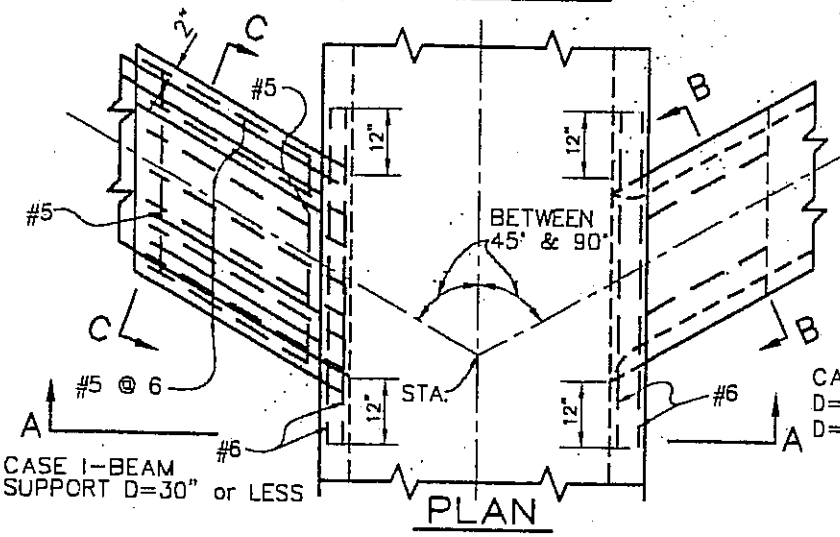

SECTION C-C

CASE 2-COLUMN SUPPORT
 D=60" OR LESS FOR C.M.P.
 D=30" OR LESS FOR R.C.P. OR C.P.

NOTES:

1. ALL CORRUGATED METAL PIPE AND FITTINGS SHALL BE GALVANIZED
2. USE JUNCTION STRUCTURE NO. 1 WHERE SIZE OF THE INLET PIPE EXCEEDS DIMENSIONS GIVEN ABOVE.
3. UNLESS OTHERWISE SPECIFIED, CASE 2 SUPPORT SHALL BE USED.
4. ELEVATION "S" SHALL BE SPECIFIED ON PROJECT DRAWINGS.

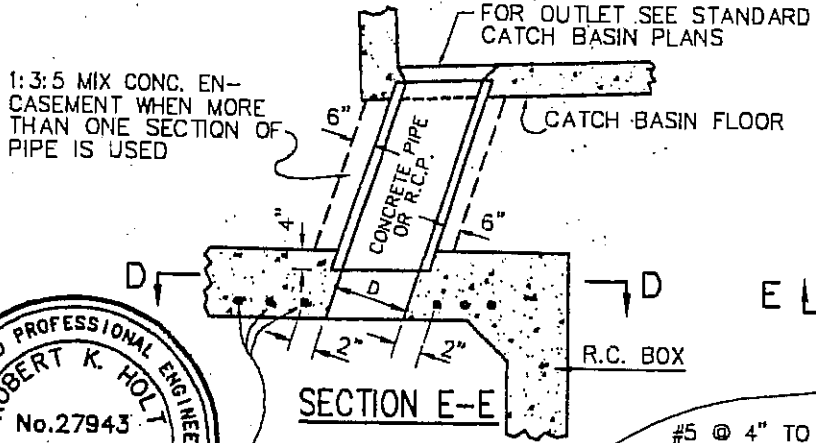

SECTION E-E

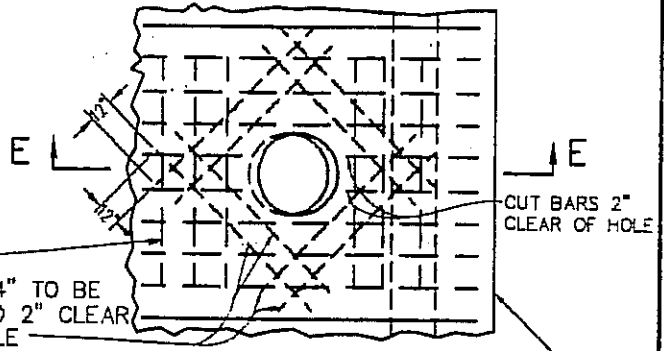

SECTION D-D

CASE 3-TOP SLAB ENTRANCE
 D=30" OR LESS

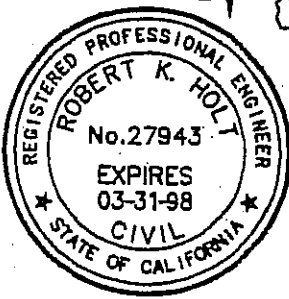

APPROVED: _____ DATE _____

APPROVED: TOWN ENGINEER
Robert K. Holt

R.C.E. 27943

REVISION	BY	DATE



Town of
Yucca Valley

JUNCTION STRUCTURE
 NO. 3

STANDARD DRAWING NO. 412

PLAIN OR REINFORCED CONCRETE PIPE OR C.M.P.

ELEVATION "S" SEE NOTE BELOW

ENDING OF INLET PIPE

BACKFILL WITH CONCRETE TO SPRING LINE OF LATERAL OR COMPACT SOIL TO RELATIVE DENSITY REQUIRED BY SPECIFICATIONS.

PIPE BEDDING
UNDISTURBED EARTH

SECTION B-B
CASE-1

BURN OR CUT PIPE TO SURFACE OF CONCRETE AND ROUND EDGES.

FOR OUTLET SEE STD. CATCH BASIN PLANS.

CATCH BASIN FLOOR

1:3:5 MIX CONC. ENCASEMENT

CASE-2

CATCH BASIN ABOVE STORM DRAIN

NOTE:

ALL CONNECTOR PIPES (WITHIN THE ANGLES SPECIFIED FOR CASE 2) SHALL BE ENCASED WHEN LAID WITHIN THE MAIN LINE EXCAVATED TRENCH, OR WHEN LAID ON FILL WHICH HAS NOT BEEN DENSIFIED.

MINIMUM BEARING SURFACE EQUALS 1/2 D.D.

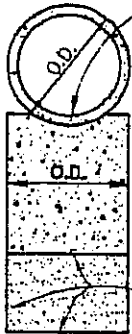

PIPE BEDDING

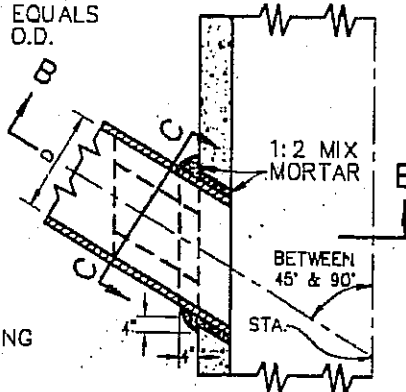

SECTION A-A

SECTION C-C

CASE-1-SIDE INLET

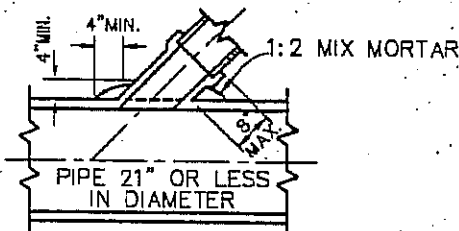

SECTION

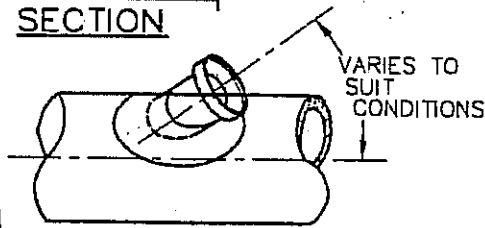

PLAN
CASE-3-SADDLE CONNECTION

NOTES: CASES 1&2

1. D SHALL BE 24" OR LESS, AND IN NO CASE SHALL THE OUTSIDE DIAMETER OF THE INLET PIPE EXCEED ONE-HALF THE INSIDE DIAMETER OF THE MAIN LINE. IF α IS 45° OR LESS, USE CASE 1. IF α IS GREATER THAN 45°, USE CASE 2.
2. C OF INLET SHALL BE ON RADIUS OF MAIN STORM DRAIN EXCEPT WHEN ELEVATION "S" IS SHOWN ON THE PROJECT DRAWING PROFILE.
3. THE MINIMUM OPENING INTO THE EXISTING STORM DRAIN SHALL BE THE OUTSIDE DIAMETER OF THE CONNECTING PIPE + 1 INCH.
4. ALL CORRUGATED METAL PIPE AND FITTINGS SHALL BE GALVANIZED.
5. STA. AT F.L. & CENTER OF PIPE, SHOWN ON PROJECT DWG. PROFILE.

NOTES: CASE-3-SADDLE CONNECTION

1. CONNECTIONS TO PIPES 21" OR LESS IN DIAMETER WITHOUT JUNCTION STRUCTURES OR PRECAST Y BRANCHES SHALL BE MADE WITH SADDLES.
2. TRIM OR CUT SADDLE TO FIT SNUGLY OVER THE OUTSIDE OF THE MAIN PIPE AND SO ITS AXIS WILL BE ON THE LINE AND GRADE OF THE CONNECTING PIPE.
3. THE OPENING INTO THE PIPE SHALL BE CUT AND TRIMMED TO FIT THE SADDLE SO THAT NO PART WILL PROJECT WITHIN THE BORE OF THE SADDLE PIPE.
4. THE CONNECTION PIPE SHALL BE SUPPORTED AS SHOWN IN CASE 1 AND 2.

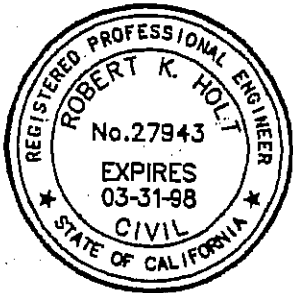

APPROVED:

DATE

APPROVED: TOWN ENGINEER

Robert K. Holt

R.C.E. 27943

REVISION

BY DATE



Town of
Yucca Valley

JUNCTION STRUCTURE
NO. 4

STANDARD DRAWING NO. 413

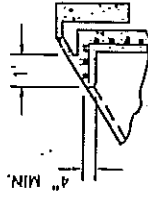
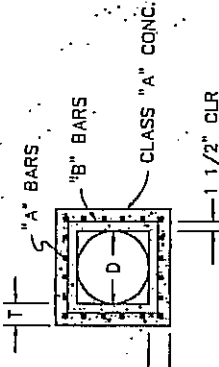
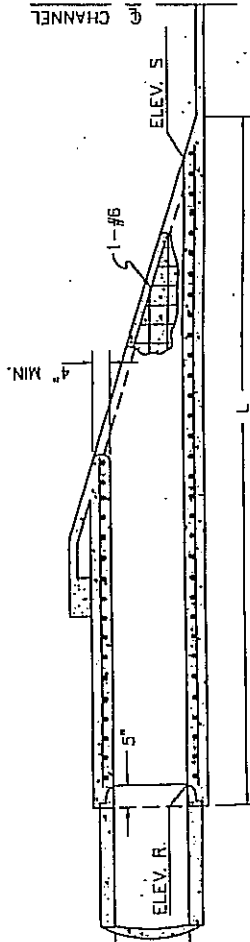
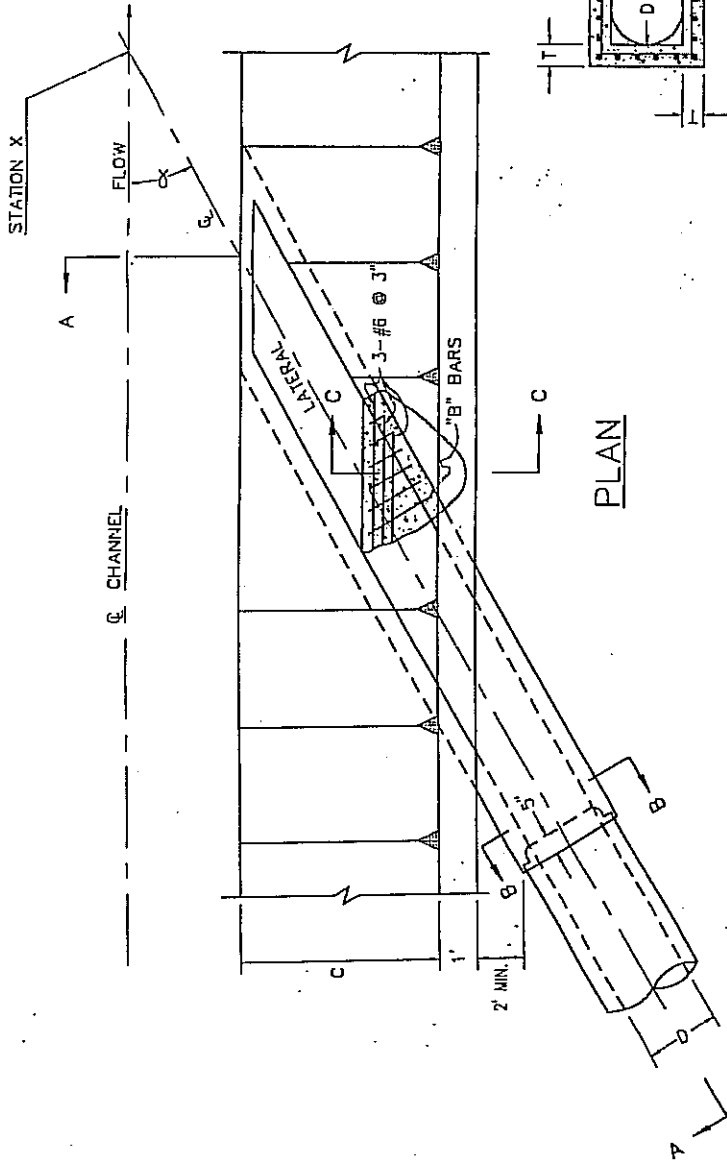

SECTION C-C

NOTES:

- VALUES FOR C, D, L, ELEV. S, ELEV. R, α AND STA. X ARE SHOWN ON PROJECT DRAWINGS.
- REINFORCING STEEL SHALL BE STRAIGHT BARS 1.5" CLEAR FROM FACE OF CONCRETE.

TABLE FOR DIMENSIONS AND BAR SIZES

D (IN.)	T (IN.)	A BARS	B BARS
18	4.5		
21	5		
24	5.25		
27	5.5		
30	6		
33	6.25		
36	6.5		
39	7		
42	7.5		
45	7.75		
48	8		
51	8.5		
54	9		
57	9.25		
60	9.5		

APPROVED: _____ DATE _____

APPROVED: TOWN ENGINEER
Robert K. Holt R.C.E. 27943

REVISION _____ BY _____ DATE _____

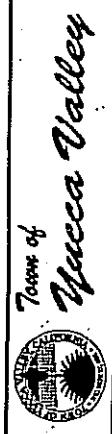

JUNCTION STRUCTURE NO. 5

STANDARD DRAWING NO. 414

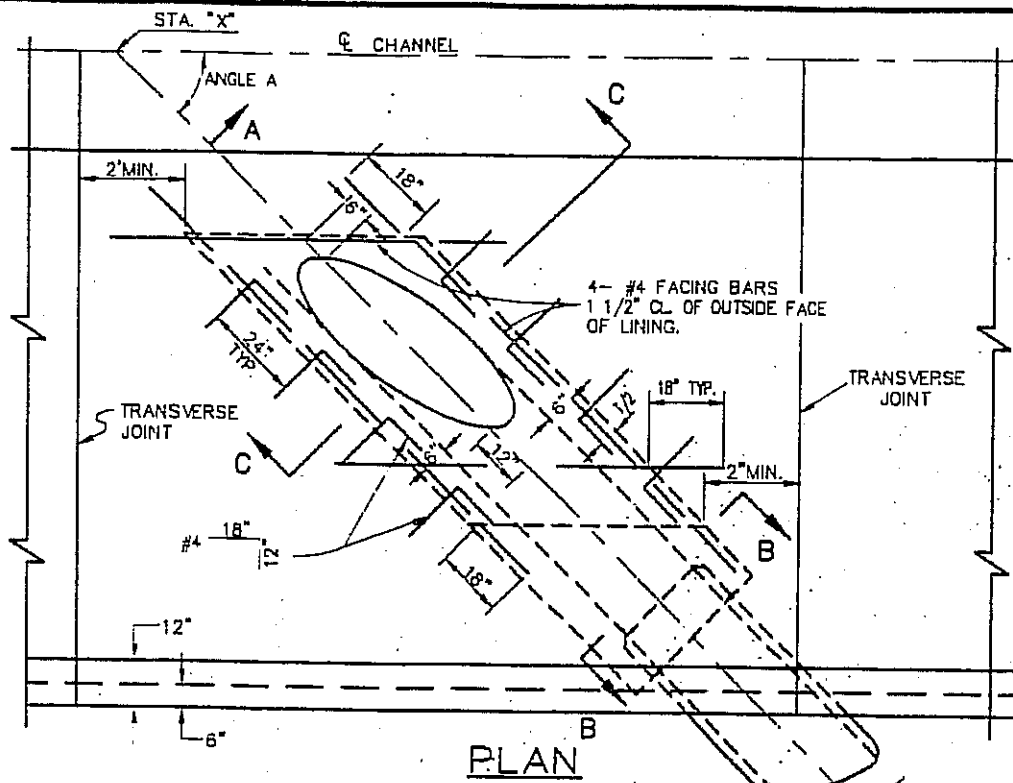
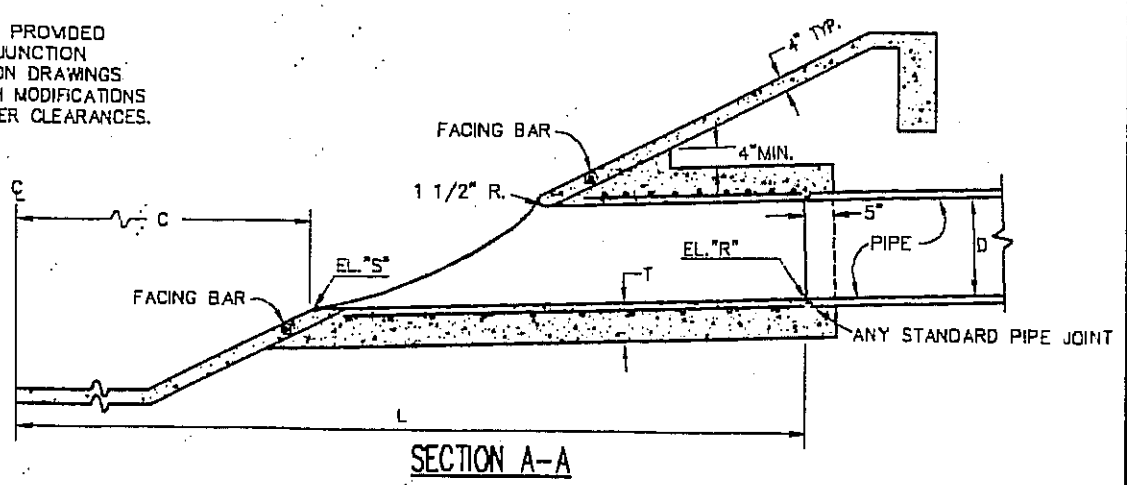
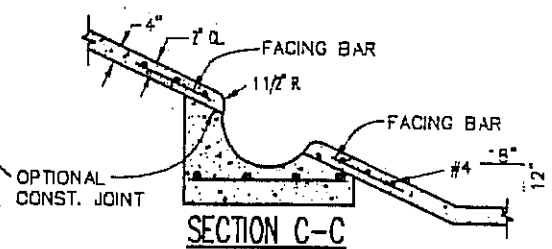
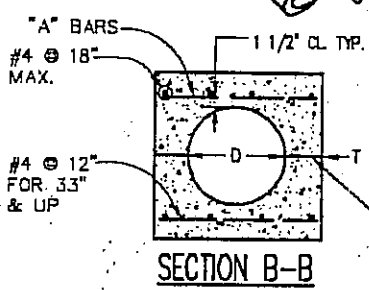

TABLE
FOR DIMENSIONS AND BAR SIZES

D (IN)	T (IN)	"A" BARS
18	9	NO
21	9	LONGITUDINAL
24	9	
27	9	
30	9	OR
33	7	"A" BARS
36	7	#4 @ 6"
39	7	
42	8	#5 @ 6"
45	8	
48	8	
51	9	
54	9	
57	10	
60	10	
63	10	
66	11	
69	11	
72	11	
78	12	
84	13	

NOTES:

- VALUES FOR D, L, C, EL. R, EL. S, ANGLE A AND STA. "X" ARE TO BE SHOWN ON PROJECT DRAWINGS.
- REINFORCING BARS SHALL BE PLACED 1 1/2" CLEAR FROM FACE OF CONCRETE.
- CONCRETE SHALL BE CLASS "B".
- PLACE #4-12"x18" BARS WITH SHORT LEG HORIZONTAL IN VERTICAL J.S. WALL. ROTATE LONGER LEG INTO CENTER OF SLOPE PAVING.
- REINFORCEMENT SHALL BE PROVIDED IN ALL PORTIONS OF THE JUNCTION STRUCTURE AS INDICATED ON DRAWINGS REGARDLESS OF BAR LENGTH MODIFICATIONS REQUIRED TO ACHIEVE PROPER CLEARANCES.



APPROVED: _____ DATE _____

APPROVED: TOWN ENGINEER
Robert K. Holt R.C.E. 27943

REVISION	BY	DATE

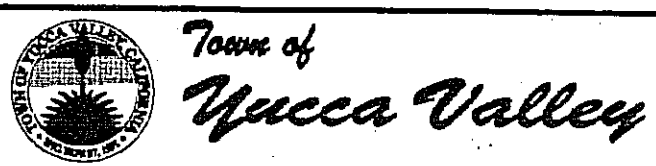

JUNCTION STRUCTURE
NO. 6

STANDARD DRAWING NO. 415

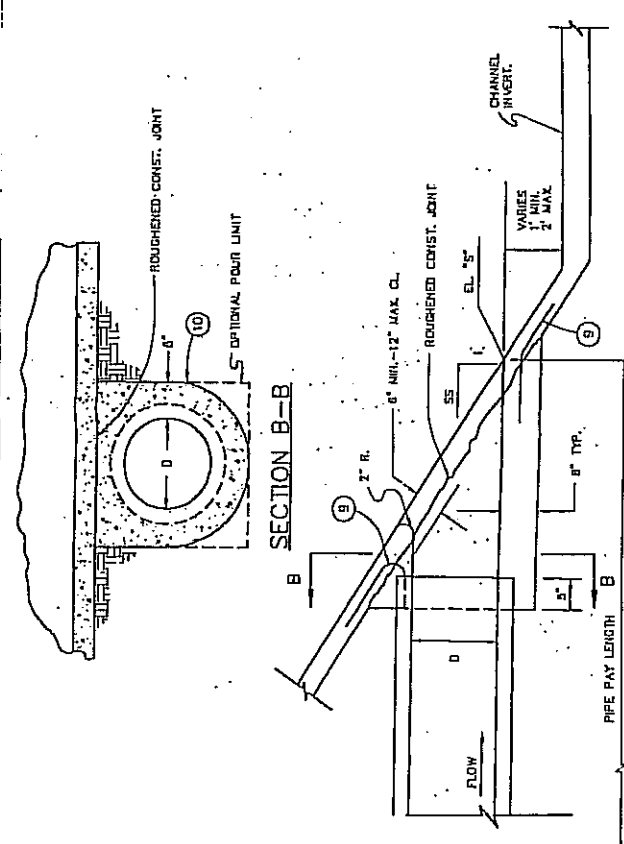
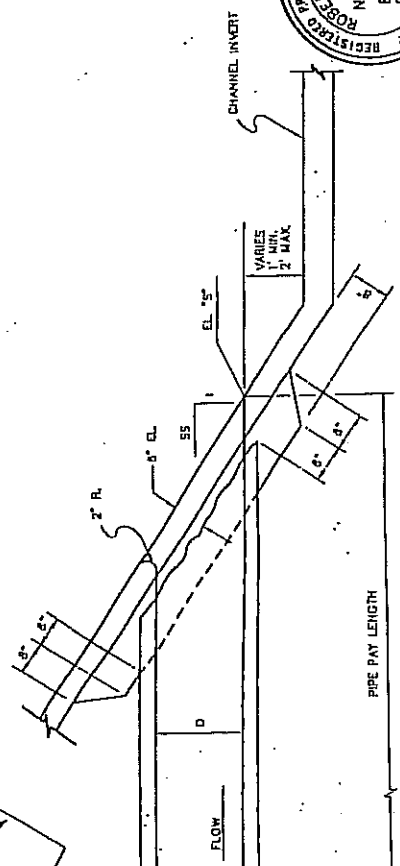
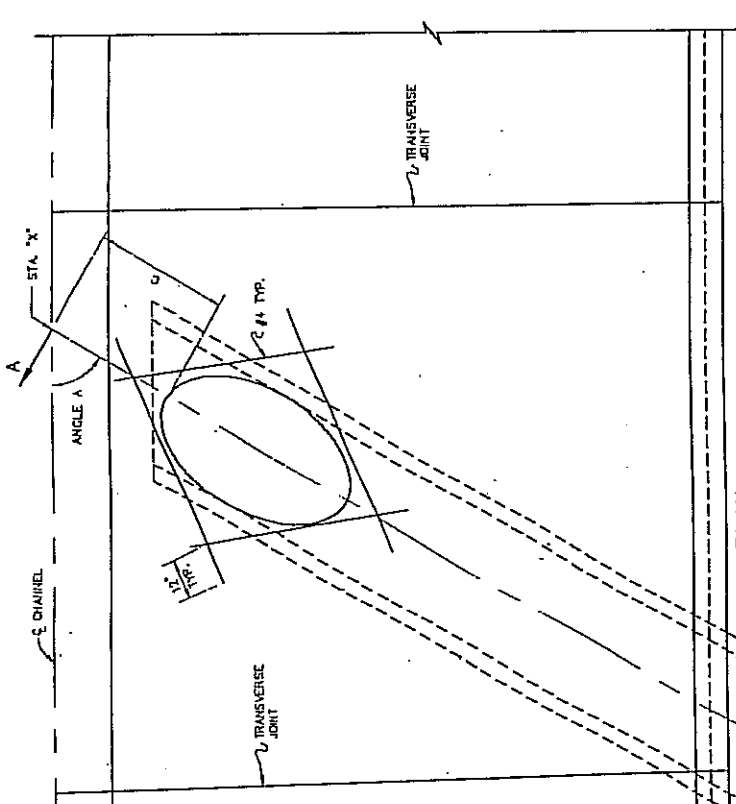

NOTES:

1. THE CONTRACTOR HAS THE OPTION TO CONSTRUCT CASE 1 OR CASE 2 UNLESS OTHERWISE NOTED.
2. HORIZONTAL ANGLE OF CONFLUENCE, "A" MUST BE BETWEEN 80° AND 90°.
3. VALUES FOR D, SS, "A", C, EL. 5", AND STA. "X" SHALL BE SHOWN ON PROJECT DRAWINGS.
4. D SHALL NOT EXCEED 24".
5. SIDE SLOPE, SS, SHALL NOT BE FLATTER THAN 2:1.
6. ALL CONCRETE SHALL BE CLASS B.
7. JUNCTION STRUCTURE NO. 7 TO BE USED ON TRAPEZOIDAL CHANNELS ONLY.
8. CASE 1 SHALL BE MONOLITHICALLY POURED WITH CHANNEL AND CASE 2 SHALL BE POURED SEPARATE FROM THE CHANNEL.
9. 1-#4 X 2' TIES SPACED EQUALLY, TYP.

APPROVED: _____ DATE _____

APPROVED: TOWN ENGINEER
Robert K. Holl R.C.E. 27943

REVISION _____ BY _____ DATE _____

TEAM OF
Nevada Valley

JUNCTION STRUCTURE NO. 7

STANDARD DRAWING NO. 416

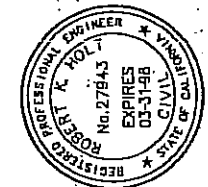

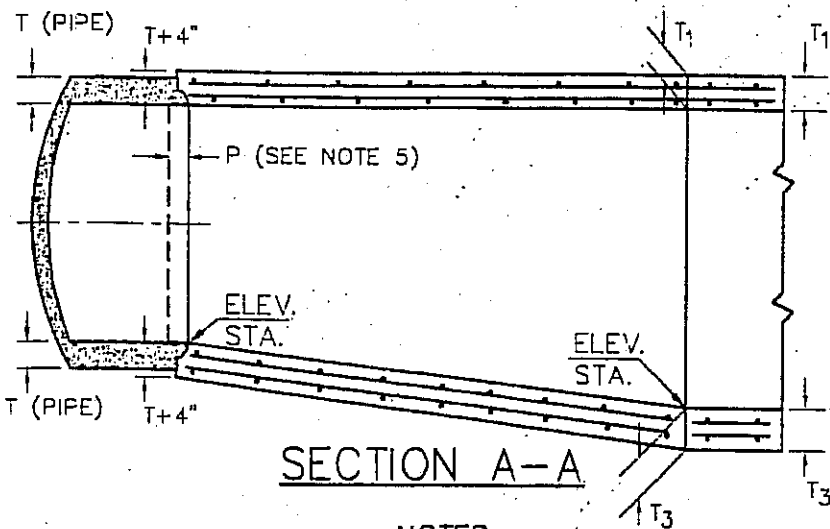
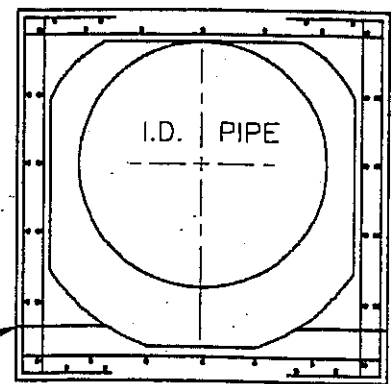
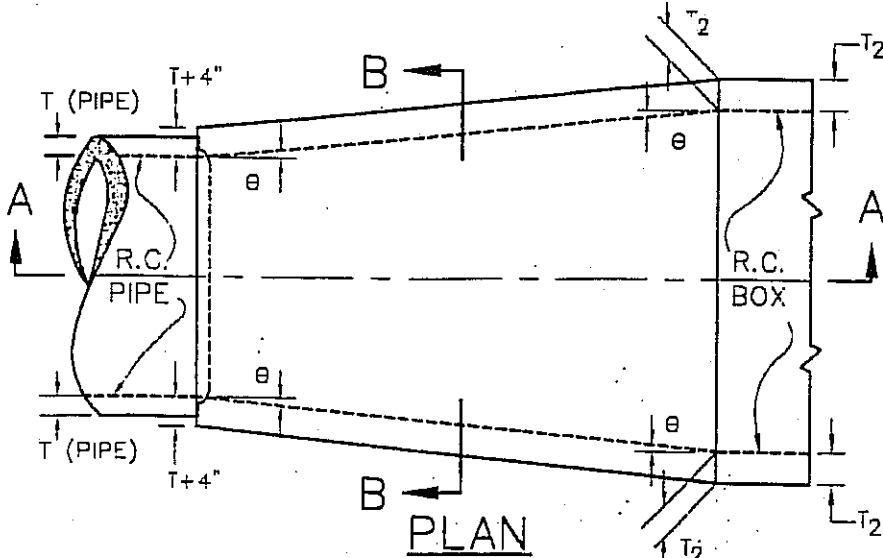

NOTES:

1. THE HORIZONTAL ANGLE OF DIVERGENCE OR CONVERGENCE, θ , SHALL NOT EXCEED 5' 45'.
2. REINFORCING STEEL BAR SIZES, SPACING, PATTERN AND COVER OVER THE STEEL SHALL BE THAT OF THE BOX SECTION. THE BAR LENGTHS SHALL VARY UNIFORMLY THROUGHOUT THE TRANSITION.
3. THE CONCRETE THICKNESS SHALL BE THAT OF THE BOX SECTION UNLESS THE WALL THICKNESS OF THE PIPE PLUS 4 INCHES IS GREATER, IN WHICH CASE THE CONCRETE THICKNESS SHALL VARY UNIFORMLY FROM THAT OF THE BOX SECTION TO THAT OF THE PIPE WALL PLUS 4 INCHES.
4. THE INTERIOR SURFACE SHALL BE SMOOTH AND VARY UNIFORMLY BETWEEN THE TWO ADJOINING SECTIONS.
5. AT THE PIPE JUNCTURE, EMBEDMENT P SHALL BE 5 INCHES FOR PIPE SIZES OF 96 INCHES OR LESS, AND 8 INCHES FOR PIPE OVER 96 INCHES.
6. CONSTRUCTION JOINTS OF THE SAME DIMENSIONS AS THOSE OF THE BOX MAY BE CARRIED THROUGH THE TRANSITION STRUCTURE AT CONTRACTOR'S OPTION. SEE SEC. B-B ABOVE.
7. THE TRANSITION STRUCTURE SHALL BE CONSTRUCTED IN ACCORDANCE WITH THE GENERAL CONSTRUCTION NOTES APPLYING TO BOX AS SHOWN ON THE PROJECT DRAWINGS.
8. STRUCTURAL CONCRETE SHALL BE CLASS "A".

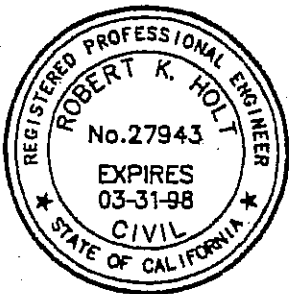

APPROVED:

DATE _____

APPROVED: TOWN ENGINEER

Robert K. Holt

R.C.E. 27943



Town of
Yucca Valley

TRANSITION STRUCTURE
NO. 1

REVISION

BY DATE

STANDARD DRAWING NO. 420

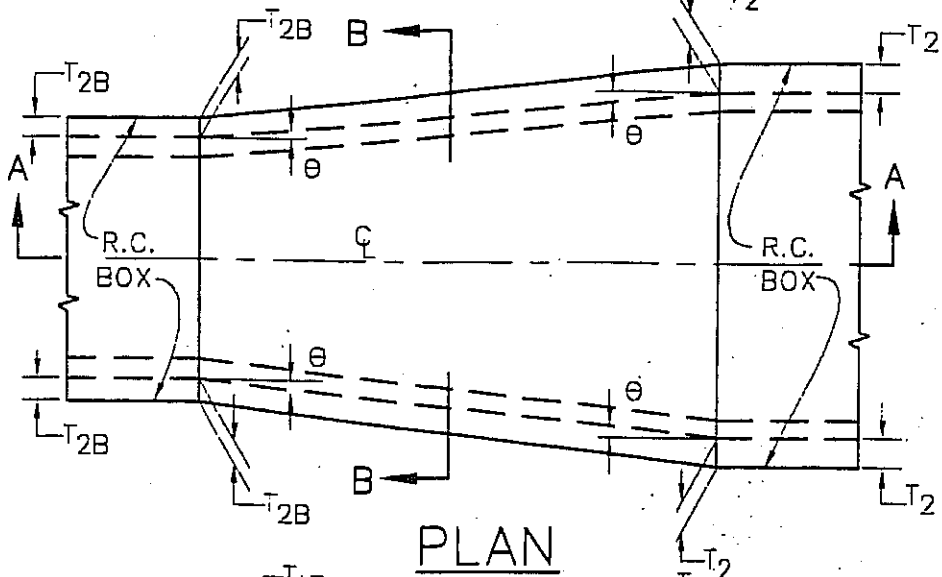

PLAN

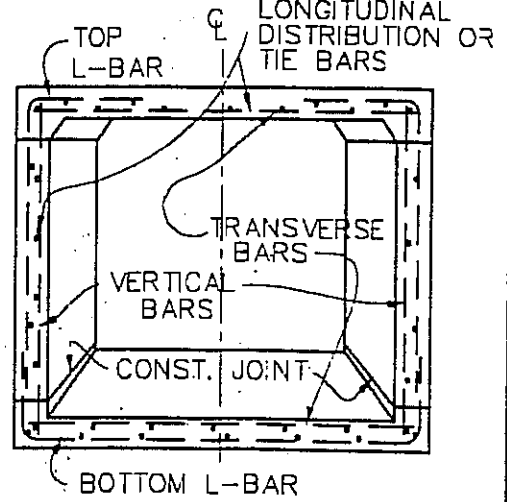

SECTION B-B

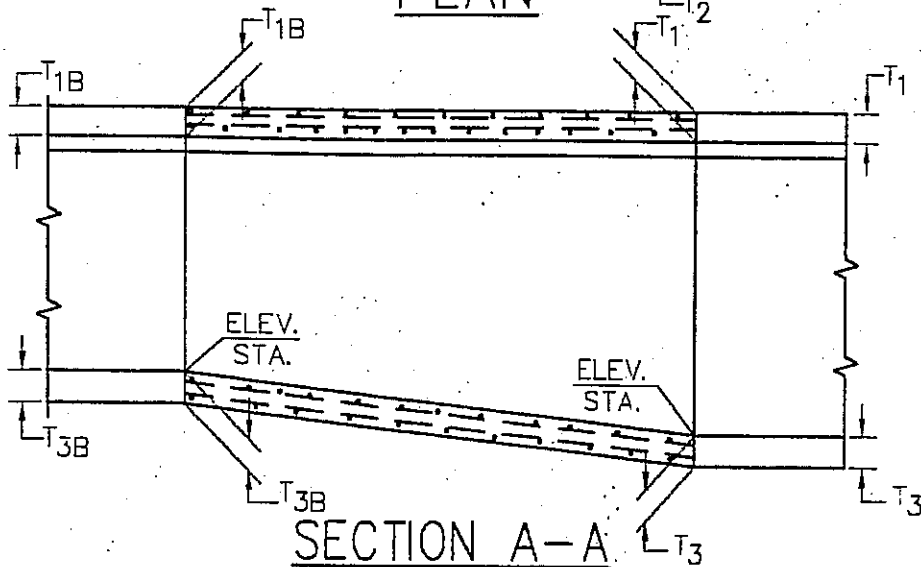

SECTION A-A

NOTES:

1. THE HORIZONTAL ANGLE OF DIVERGENCE OR CONVERGENCE, θ SHALL NOT EXCEED $5^{\circ}45'$.
2. THE REINFORCING STEEL BAR SIZE, SPACING AND COVER OVER THE STEEL OF STRAIGHT TRANSVERSE BARS IN TOP OR BOTTOM SLABS, OF L-BARS IN TOP OR BOTTOM CORNERS, OF STRAIGHT VERTICAL BARS IN SIDE WALLS, AND OF LONGITUDINAL DISTRIBUTION AND TIE BARS IN TOP OR BOTTOM SLABS OR SIDE WALLS SHALL BE THOSE OF WHICH-EVER ADJOINING BOX SECTION PROVIDES THE GREATER STEEL AREA FOR EACH TYPE OF BAR. THE BAR LENGTH SHALL VARY UNIFORMLY THROUGHOUT THE TRANSITION.
3. THE THICKNESS OF THE WALLS AND SLABS SHALL BE THOSE OF THE ADJOINING BOX SECTION AT EACH OF THE TRANSITION AND SHALL VARY UNIFORMLY BETWEEN THE TWO ENDS.
4. STRUCTURAL CONCRETE SHALL BE CLASS "A".
5. THE TRANSITION STRUCTURE SHALL BE CONSTRUCTED IN ACCORDANCE WITH THE GENERAL STRUCTURAL NOTES APPLYING TO BOX STRUCTURES, SHOWN ON THE PROJECT DRAWINGS.
6. DETAILS OF CONSTRUCTION JOINTS SHALL BE AS SHOWN ON THE PROJECT DRAWINGS FOR SINGLE BARREL BOX STRUCTURES.

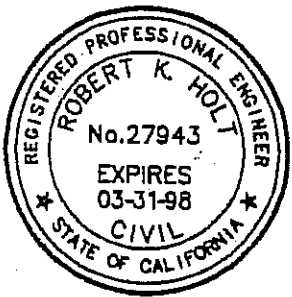

APPROVED:

DATE _____

APPROVED: TOWN ENGINEER

Robert K. Holt

R.C.E. 27943



Town of
Yucca Valley

TRANSITION STRUCTURE
NO. 2

REVISION _____ BY _____ DATE _____

STANDARD DRAWING NO. 421

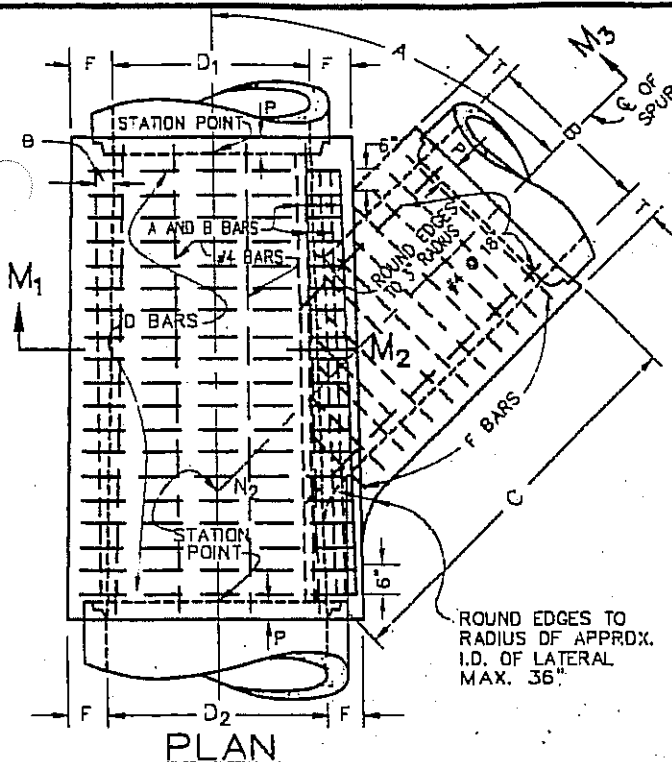

PLAN

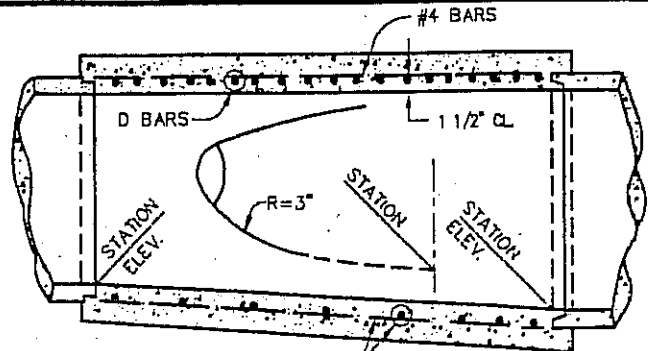

LONGITUDINAL SECTION

#4 @ 18" E.W. WHEN D₂ IS 60" OR MORE

ROUND EDGES TO RADIUS OF APPROX. I.D. OF LATERAL MAX. 36"

* USE D₂ OR D₁; WHICHEVER IS GREATER, OR B.

TABLE FOR DIMENSIONS AND BAR SIZE

* D ₂ , D ₁ OR B	T	A OR B BARS	D OR F BARS	P
12	4	# 5 @ 3	# 4 @ 6	5"
15	4 1/4			
18	4 1/2			
21	5			
24	5 1/4			
27	5 1/2			
30	6			
33	6 1/4			
36	6 1/2			
39	7			
42	7 1/2	# 6 @ 3	# 5 @ 6	5"
45	7 3/4			
48	8			
51	8 1/2			
54	9			
57	9 1/4			
60	9 1/2			
63	10			
66	10 1/4			
69	10 3/4			
72	11	# 7 @ 3	# 6 @ 6	6"
78	11 3/4			
84	12 1/2			
90	13 1/4			
96	14			
102	15 1/2			
108	16			
114	16 1/2			
120	17			
126	17			
132	17 1/2			
138	17 1/2			
144	18			

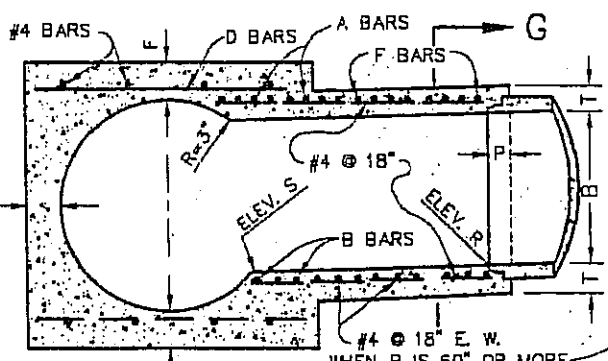

SECTION M₁, M₂, M₃

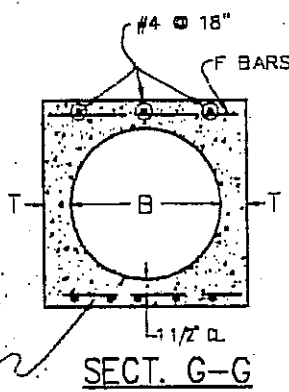

SECT. G-G

NOTES:

1. THE HORIZONTAL ANGLE OF DIVERGENCE OR CONVERGENCE, θ, SHALL NOT EXCEED 5°45'.
2. VALUES FOR A, B, C, D₁, D₂, ELEV. R AND ELEV. S ARE SHOWN ON IMPROVEMENT PLAN. THE LENGTH OF THE STRUCTURE MAY BE INCREASED TO MEET PIPE ENDS USING D BARS IN EXTENDED PORTION OF SAME DIAMETER AND SPACING AS SPECIFIED.
3. CONCRETE SHALL BE CLASS "A". FLOOR OF THE STRUCTURE SHALL BE STEEL-TROWELED TO SPRING LINE. STRUCTURE SHALL BE POURED IN ONE CONTINUOUS OPERATION, EXCEPT THAT THE CONTRACTOR SHALL HAVE THE OPTION OF PLACING AT THE SPRING LINE A CONSTRUCTION JOINT WITH A LONGITUDINAL KEYWAY.
4. REINFORCING STEEL CLEAR COVER SHALL BE 1 1/2" ON INSIDE. TIE BARS SHALL BE NO. 4 AND SPACED 18" O.C.
5. WHEN DIMENSION C IS NOT SPECIFIED THE SPUR SHALL NOT BE CONSTRUCTED AND A AND B BARS SHALL BE OMITTED.

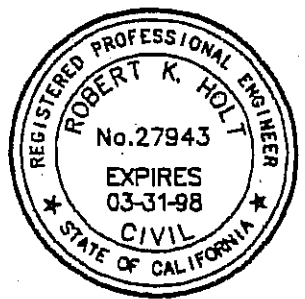

APPROVED: _____ DATE _____

APPROVED: TOWN ENGINEER
Robert K. Holt R.C.E. 27943

REVISION	BY	DATE



Town of
Yucca Valley

TRANSITION STRUCTURE
NO. 3

STANDARD DRAWING NO. 422

STRUCTURAL ANALYSIS REQUIRED
WHEN THIS DIMENSION EXCEEDS 1'-6"

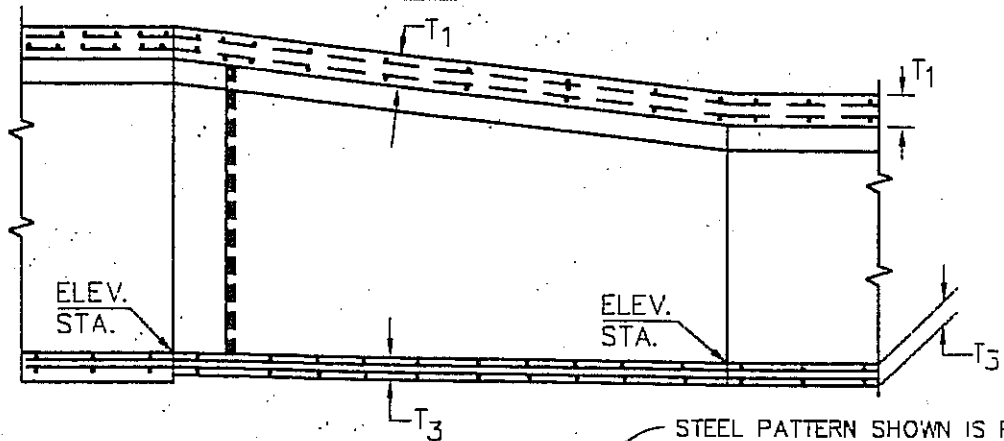
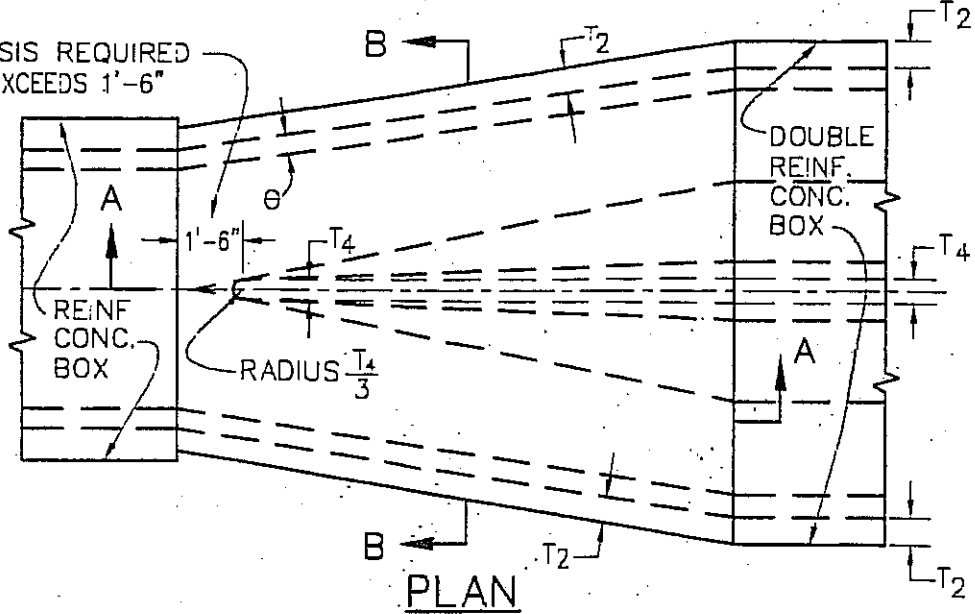

SECTION A-A

NOTES:

1. THE HORIZONTAL ANGLE OF DIVERGENCE OR CONVERGENCE, θ SHALL NOT EXCEED $5^\circ 45'$.
2. REINFORCING STEEL BAR SIZE, SPACING AND OUTSIDE COVER SHALL BE THAT OF DOUBLE BOX SECTION. FOR CURVED TRANSITIONS, SPACE BARS ON CENTERLINE AND PLACE TRANSVERSE STEEL RADIALLY. THE BAR LENGTHS AND DIMENSIONS SHALL VARY UNIFORMLY THROUGHOUT TRANSITION. LONGITUDINAL BARS SHALL BE CONTINUED THROUGH JOINTS WITH THE TRANSITION STRUCTURE.
3. THE CONCRETE THICKNESS SHALL BE THAT OF THE DOUBLE BOX SECTION.
4. PLAN AS SHOWN IS FOR DOUBLE BOX SECTION DOWNSTREAM. WHEN DOUBLE BOX SECTION IS UPSTREAM, TAPER THE LAST 2 FT. OF CENTER WALL TO END IN 1-1/2 INCH RADIUS.
5. STRUCTURAL CONCRETE SHALL BE CLASS "A".
6. TRANSVERSE JOINT KEYWAYS AS DETAILED FOR LONGITUDINAL JOINT KEYWAYS AT BASE OF OUTER WALLS ON THE PROJECT DRAWINGS, SHALL BE PLACED IN BOTH SLABS AND WALLS AT THE END OF EACH POUR.

STEEL PATTERN SHOWN IS PICTORIAL ONLY. SEE PROJECT DRAWINGS FOR ACTUAL STEEL LAYOUT.

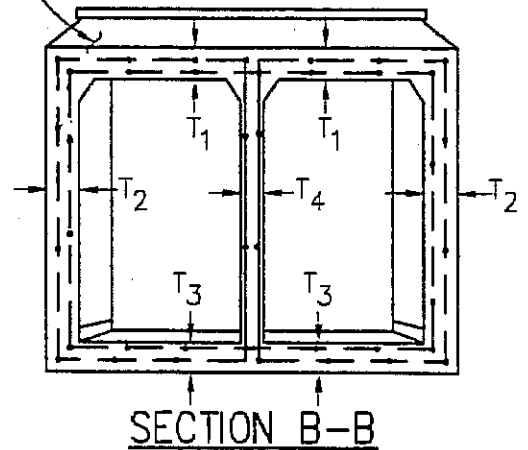

SECTION B-B



APPROVED:

DATE

APPROVED: TOWN ENGINEER

Robert K. Holt

R.C.E. 27943



Town of
Yucca Valley

TRANSITION STRUCTURE
NO. 4

REVISION BY DATE

STANDARD DRAWING NO. 423

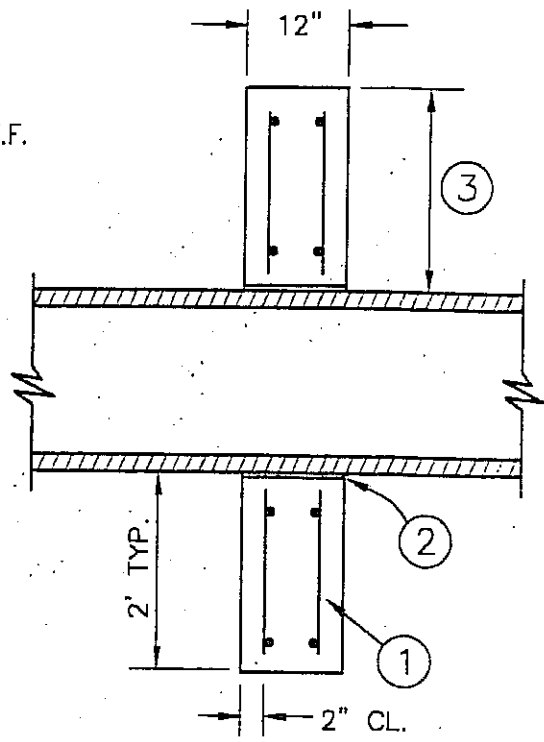
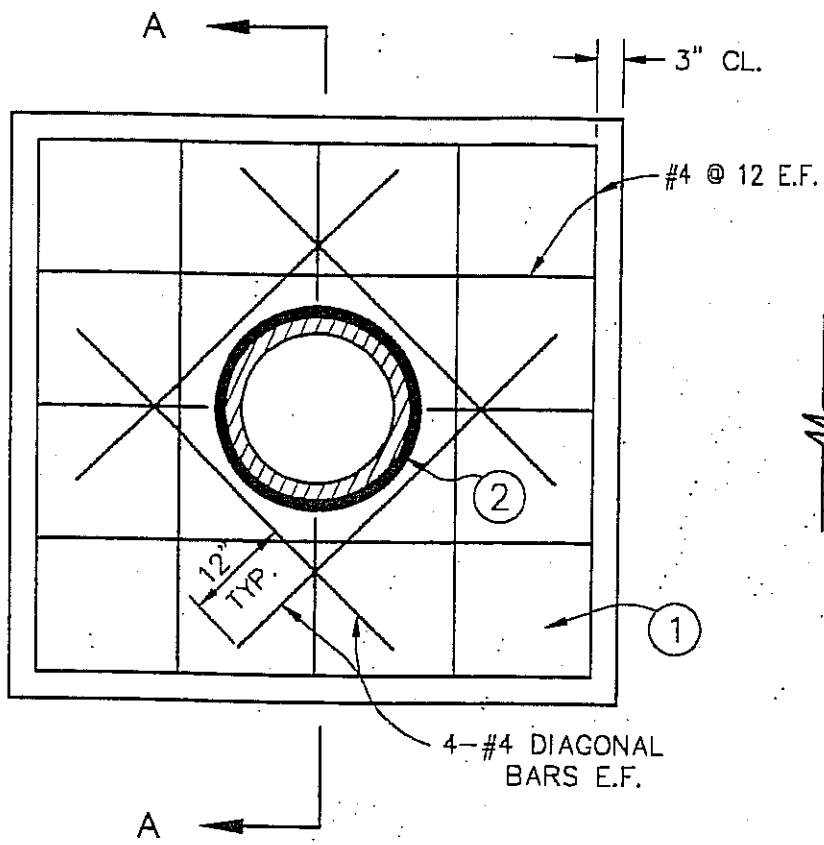

TYPICAL SECTION

SECTION A-A

CONNECTOR PIPE COLLAR

NOTES:

- ① CONCRETE SHALL BE CLASS "B" CONCRETE.
- ② 1/2" PREFORMED BITUMINOUS JOINT MATERIAL.
- ③ 2' WITH MIN. 6" BELOW GRADE OR AS DIRECTED BY ENGINEER.

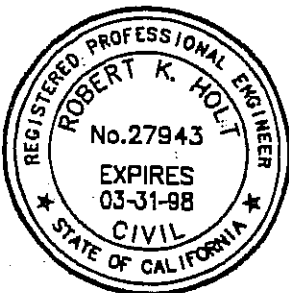

APPROVED: _____ DATE _____

APPROVED: TOWN ENGINEER
Robert K. Holt R.C.E. 27943

REVISION	BY	DATE



Town of
Yucca Valley

CONNECTOR PIPE
 COLLAR

STANDARD DRAWING NO. 430

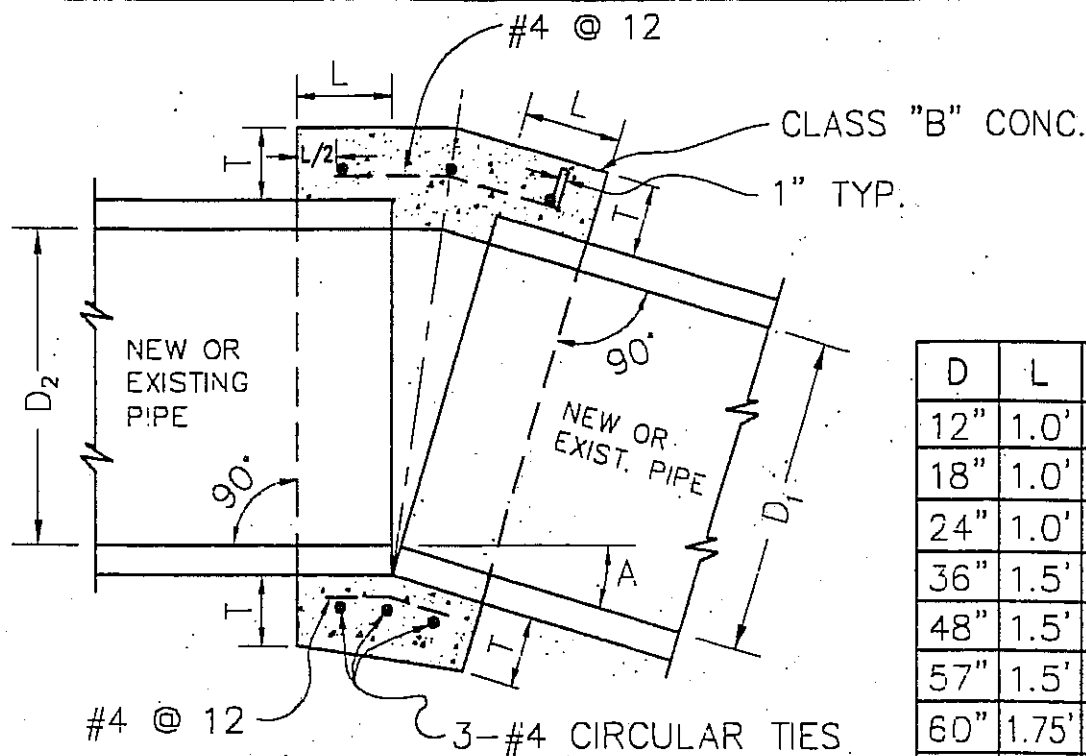

D	L	T
12"	1.0'	4"
18"	1.0'	5"
24"	1.0'	6"
36"	1.5'	8"
48"	1.5'	10"
57"	1.5'	10"
60"	1.75'	11"
66"	1.75'	11"

NOTES:

1. A CONCRETE COLLAR IS REQUIRED WHERE THE CHANGE IN GRADE EXCEEDS 0.10 FT. PER FOOT, OR IF CHANGE IN ALIGNMENT EXCEEDS 0.10 FT PER FOOT.
2. WHERE PIPES OF DIFFERENT DIAMETERS ARE JOINED WITH A CONCRETE COLLAR, L AND T SHALL BE THOSE OF THE LARGER PIPE. $D = D_1$ OR D_2 WHICHEVER IS GREATER.
3. FOR PIPE LARGER THAN 66" A SPECIAL COLLAR DETAIL IS REQUIRED.
4. FOR PIPE SIZE NOT LISTED USE NEXT SIZE LARGER.
5. OMIT REINFORCING ON PIPES 24" AND LESS IN DIAMETER AND ON ALL PIPES WHERE ANGLE "A" IS LESS THAN 10°.
6. WHERE REINFORCING IS REQUIRED, THE DIAMETER OF THE CIRCULAR TIES SHALL BE $D + (2 \times \text{WALL THICKNESS}) + 8"$.
7. WHEN D_1 IS EQUAL TO OR LESS THAN D_2 , JOIN INVERTS AND WHEN D_1 IS GREATER THAN D_2 , JOIN SOFFITS.
8. PIPE MAY BE CORRUGATED METAL PIPE, CONCRETE PIPE, OR REINFORCED CONCRETE PIPE.

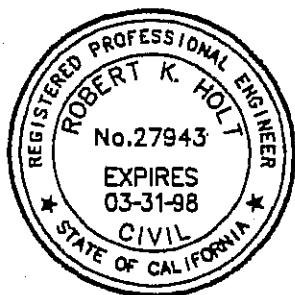

APPROVED:

DATE _____

APPROVED: TOWN ENGINEER

Robert K. Holt

R.C.E. 27943



Town of
Yucca Valley

CONCRETE COLLAR
FOR PIPE 12 INCHES THROUGH
66 INCHES

STANDARD DRAWING NO. 431

REVISION

BY DATE

HEADWALL SHALL BE MONOLITHIC.
LAP ALL BARS AT CORNERS 30 DIAMETERS
IF NOT CONTINUOUS.

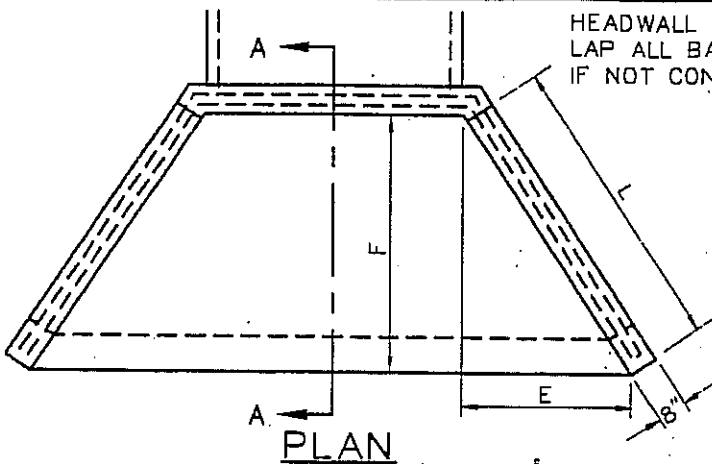

PLAN

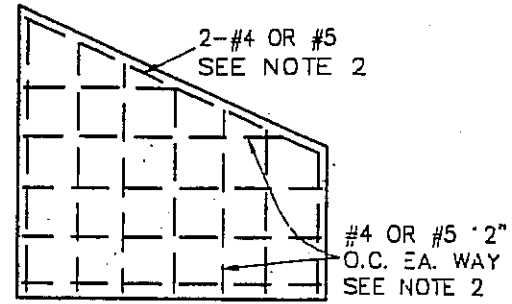

REINFORCING DETAIL

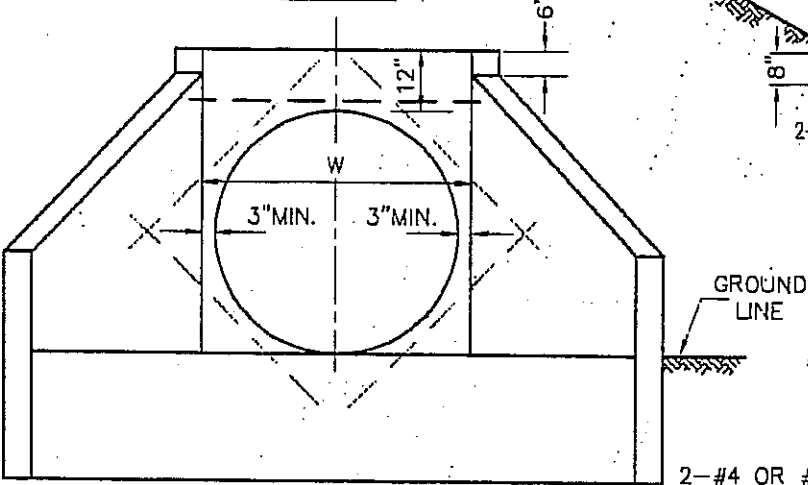

ELEVATION

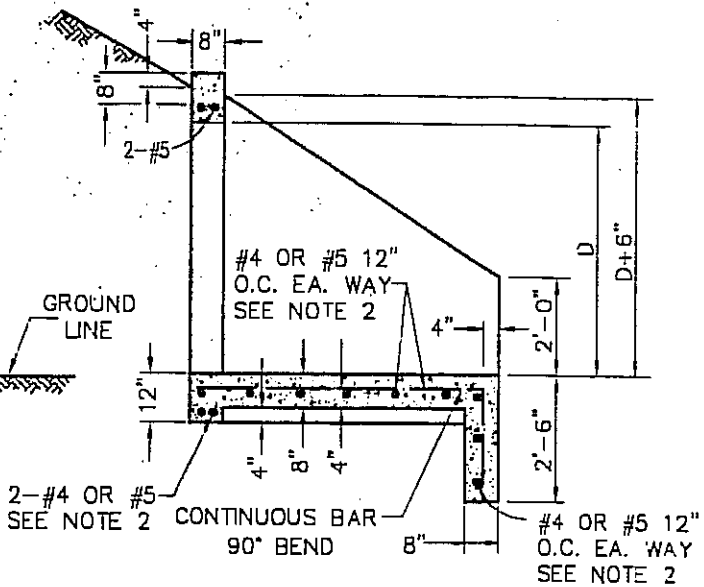

SECTION A-A

DIMENSIONS				
PIPE DIA.	L	E	F	W
24"	4'-9"	2'-8"	4'-0"	2'-6"
30"	5'-5"	3'-0"	4'-6"	3'-0"
36"	6'-0"	3'-4"	5'-0"	3'-8"
42"	6'-7"	3'-8"	5'-6"	4'-2"
48"	7'-3"	4'-0"	6'-0"	4'-10"
54"	8'-2"	4'-6"	6'-9"	5'-4"

NOTES:

1. HEADWALL SHALL BE CONSTRUCTED OF CLASS "A" CONCRETE.
2. REINFORCING STEEL SHALL BE #4 BARS FOR "W" UP TO 60". ABOVE "W"=60" #5 BARS SHALL BE USED. 2" MINIMUM CLEARANCE, 30 DIAMETER LAP, ALL STEEL.
3. ADJACENT SLOPES SHALL BE 1-1/2 TO 1 OR FLATTER.
4. MULTIPLE PIPES TO BE SET WITH LONGITUDINAL CENTERS 1-2/3 DIAMETERS APART.
5. ALL EXPOSED CORNERS TO BE ROUNDED 3/4" RADIUS.
6. W SHALL BE INCREASED WHEN MULTIPLE PIPES OR PIPES ON SKEW ARE USED.

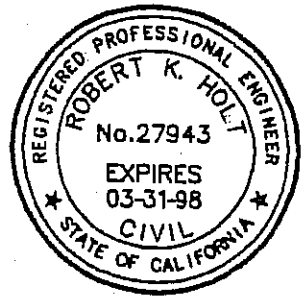

APPROVED: _____ DATE _____

APPROVED: TOWN ENGINEER
Robert K. Holt R.C.E. 27943

REVISION	BY	DATE



Town of
Yucca Valley

HEADWALL
WING - TYPE

STANDARD DRAWING NO. 440

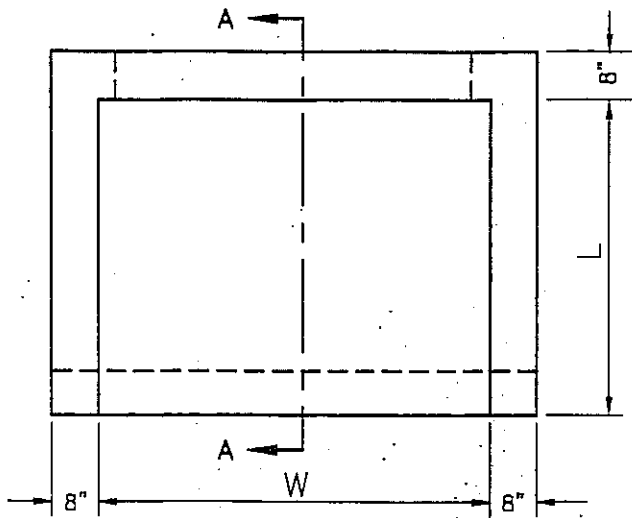

PLAN

DIMENSIONS		
PIPE DIA.	L	W
24"	4'-0"	2'-6"
30"	4'-6"	3'-0"
36"	5'-0"	3'-8"
42"	5'-6"	4'-2"
48"	6'-0"	4'-10"
54"	6'-9"	5'-4"

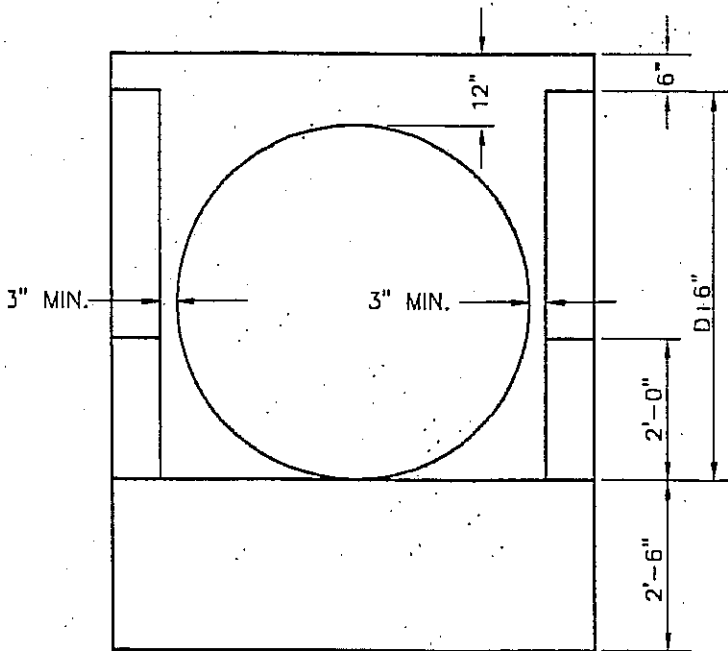

ELEVATION

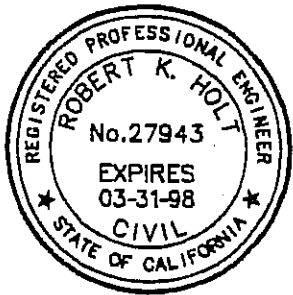

NOTES:

1. REINFORCING STEEL IN WALLS AND BASE SHALL BE THE SAME AS STD. NO. 440.
2. NOTES SHALL BE THE SAME AS STD. NO. 440.
3. SECTION A-A IS THE SAME AS STD. NO. 440.

APPROVED:

DATE _____

APPROVED: TOWN ENGINEER

Robert K. Holt

R.C.E. 27943



Town of
Yucca Valley

HEADWALL
"U" - TYPE

REVISION

BY DATE

STANDARD DRAWING NO. 441

NOTE: 12" OF AGGREGATE BASE REQUIRED ON GRADED ROADS.

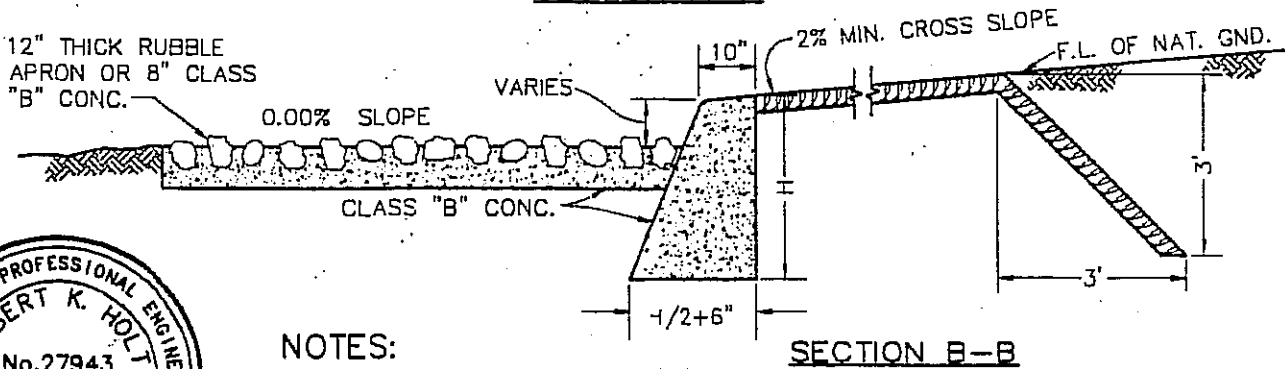
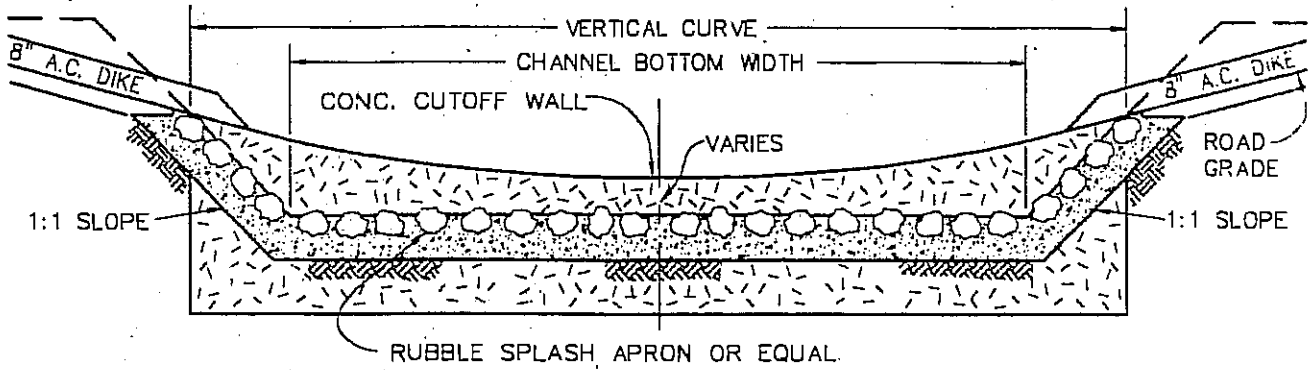
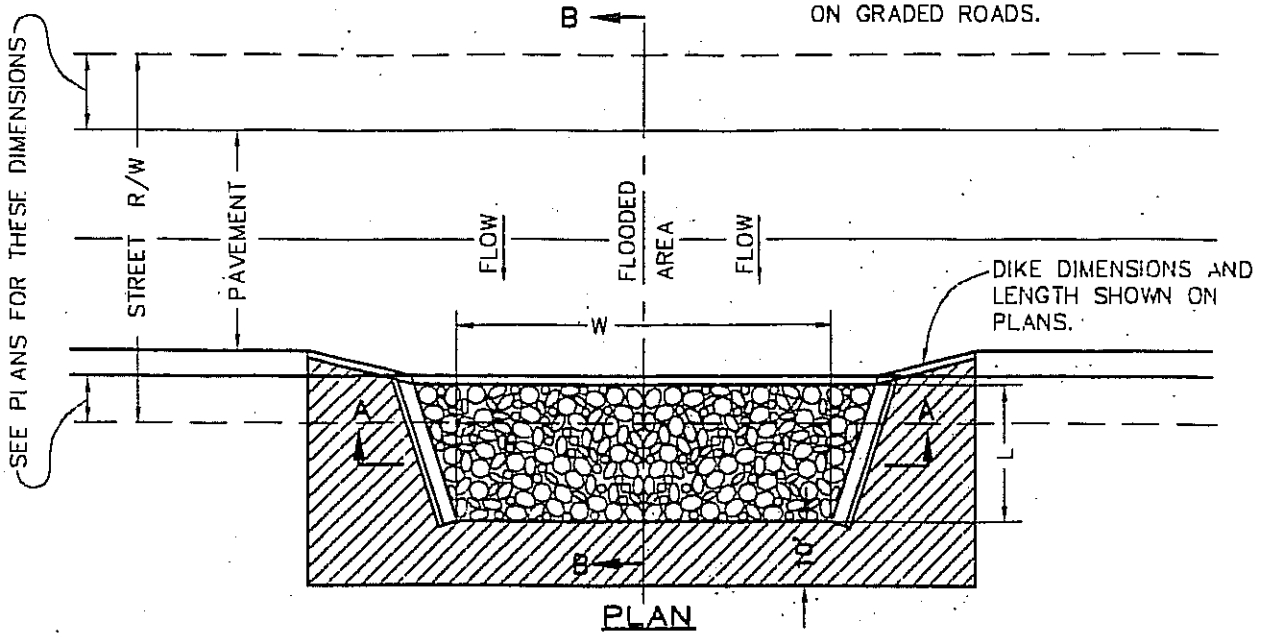

NOTES:

1. ALL CONCRETE TO BE CLASS "B".
2. L= SHOWN ON PLANS, H= 3' MIN., 6' MAX.
3. DRAINAGE EASEMENT REQUIRED.
4. AREA SHOWN THUS SHALL BE COMPACTED TO 90% RELATIVE DENSITY.
5. REINFORCED BLOCK WALL AND FOOTING PERMITTED.

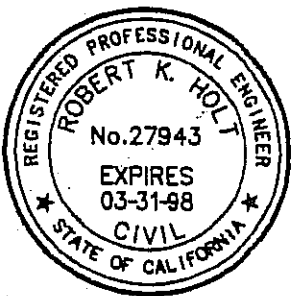

APPROVED:

DATE _____

APPROVED: TOWN ENGINEER

Robert K. Holt

R.C.E. 27943



Town of
Yucca Valley

CUTOFF WALL FOR
DRAINAGE CHANNEL

REVISION

BY DATE

STANDARD DRAWING NO. 450

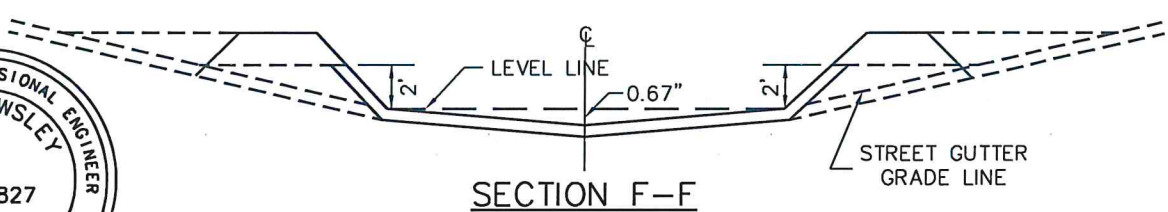
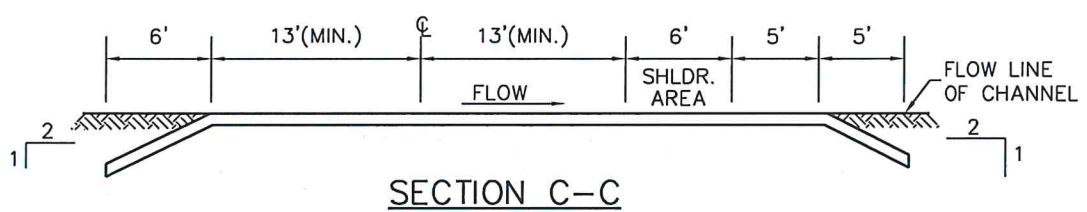
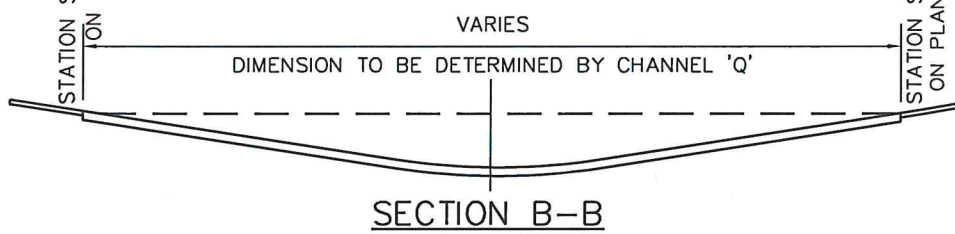
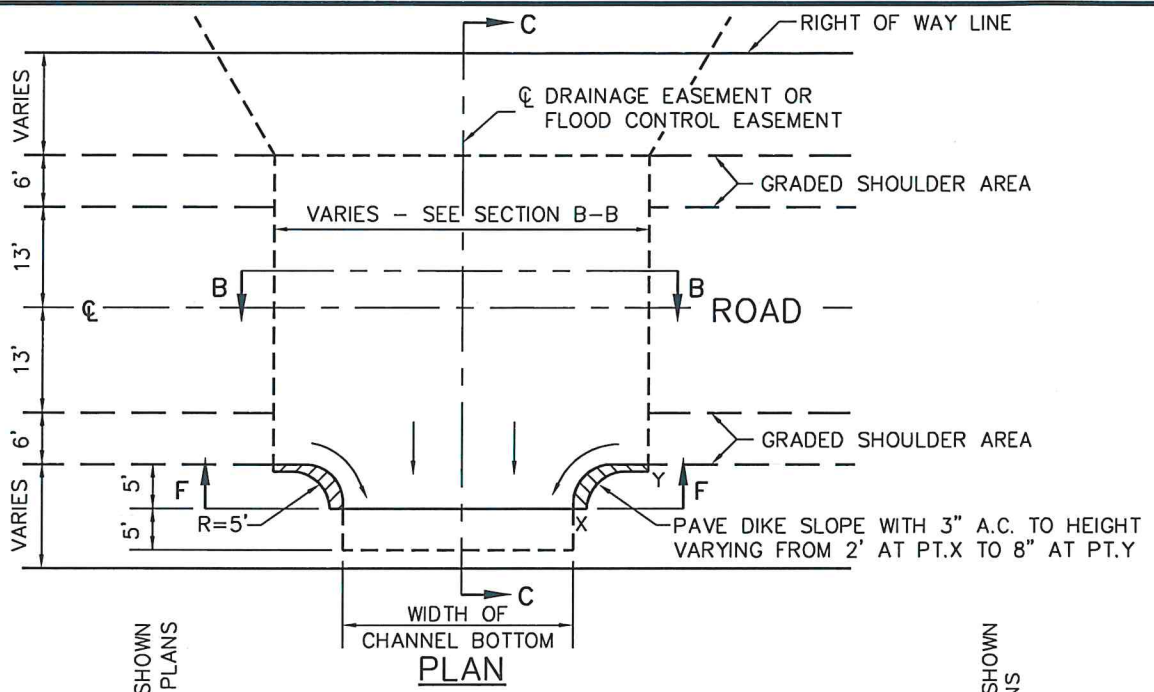

NOTE:
PAVEMENT SHALL BE CONSTRUCTED OF 4" MIN. THICK PG 70-10 ASPHALT CONCRETE.

APPROVED: DIRECTOR OF PUBLIC WORKS
Alex Quisita DATE *4/21/25*

APPROVED: TOWN ENGINEER
Noel Owsley R.C.E. 39827

REVISION	BY	DATE



Town of
Yucca Valley

CHANNEL CROSSING

STANDARD DRAWING NO. 451

GRATE (OR CHECKERED P
 OPTIONAL) SEE STANDARD
 DRAWING 461

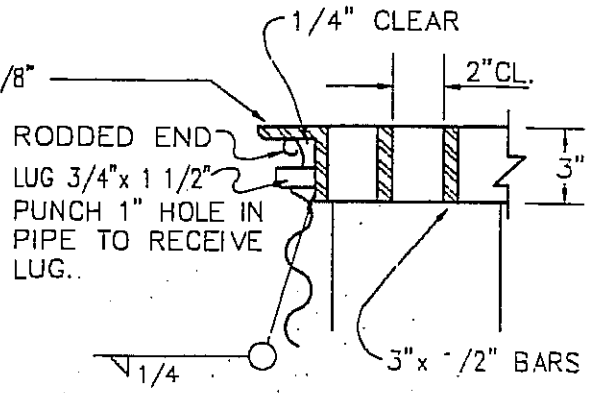
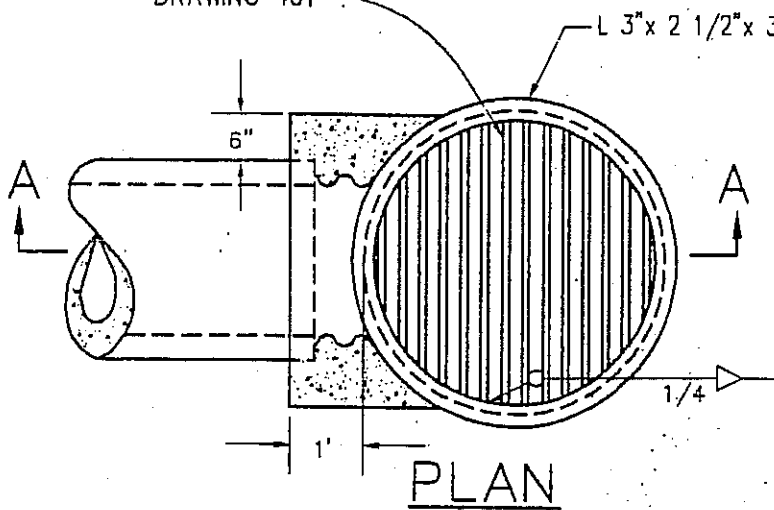

DETAIL "B"

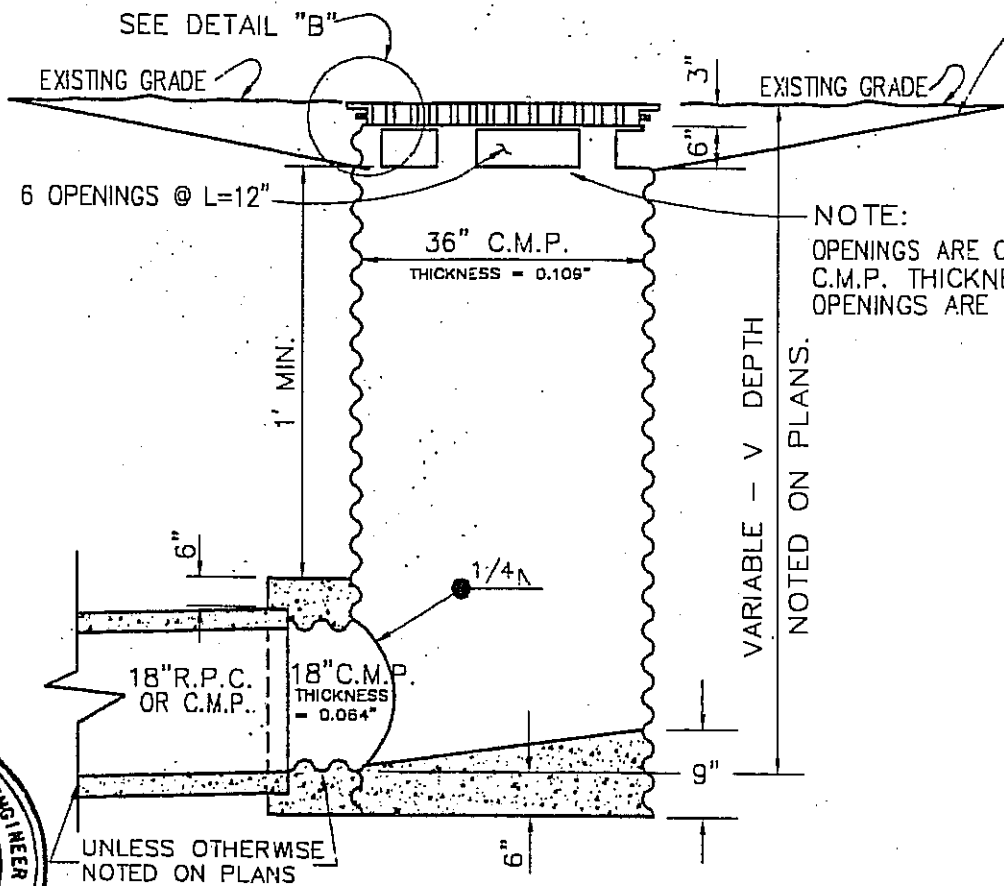

SECTION A-A

GRADE 6" MIN. CIRCLE
 AROUND INLET WHERE
 POSSIBLE.

NOTE:
 OPENINGS ARE OPTIONAL USE 36"
 C.M.P. THICKNESS=0.064 WHEN
 OPENINGS ARE OMITTED.

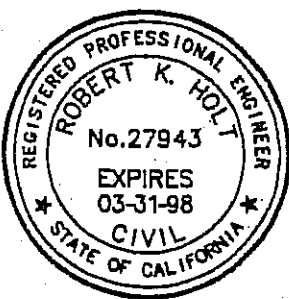

UNLESS OTHERWISE
 NOTED ON PLANS

- NOTES:**
1. PLACE GRATE BARS PARALLEL TO FLOW.
 2. GRATE AND FRAME SHALL BE GALVANIZED.

APPROVED:	DATE
APPROVED: TOWN ENGINEER <i>Robert K. Holt</i>	R.C.E. 27943
REVISION	BY DATE



*Town of
 Yucca Valley*

INLET TYPE X
 (GRATE DETAILS)

STANDARD DRAWING NO. 460

4-3/8" x 1 1/2" BOLTS

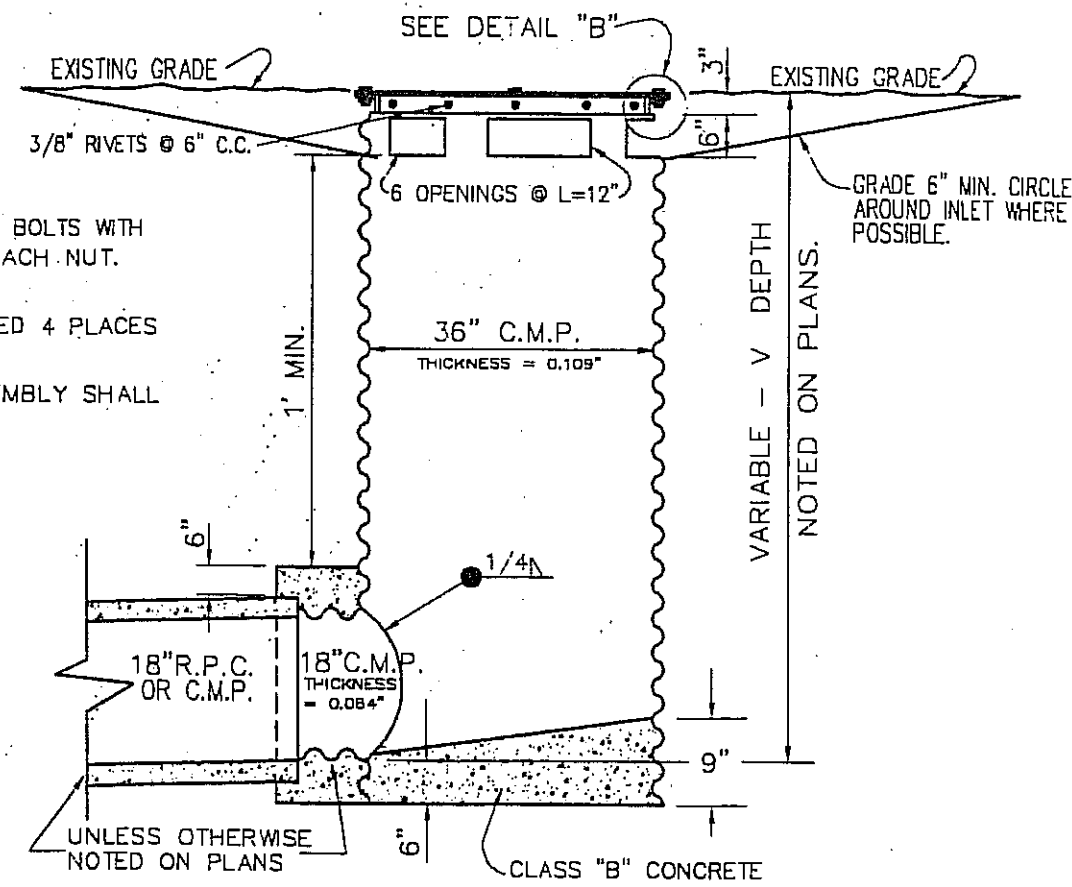
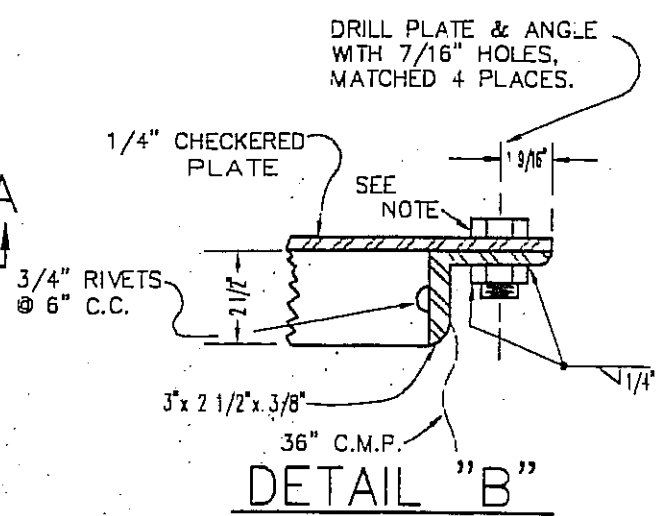
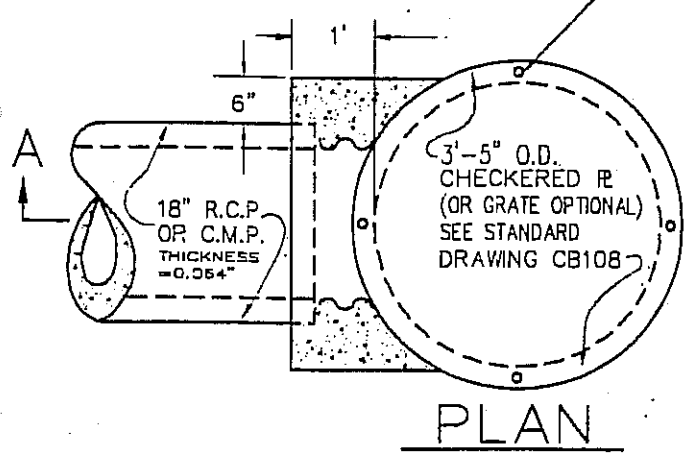

NOTES:

1. 3/8" x 1 1/2" GALVANIZED BOLTS WITH HEX NUTS. FIELD WELD EACH NUT TO ANGLE.
2. DRILL HOLE 7/16" MATCHED 4 PLACES AS SHOWN IN PLAN.
3. PLATE AND ANGLE ASSEMBLY SHALL BE GALVANIZED.

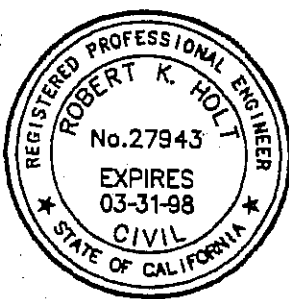

APPROVED:	DATE
APPROVED: TOWN ENGINEER <i>Robert K. Holt</i>	R.C.E. 27943
REVISION	BY DATE



Town of
Yucca Valley

INLET TYPE IX
(CHECKERED PLATE)

STANDARD DRAWING NO. 461

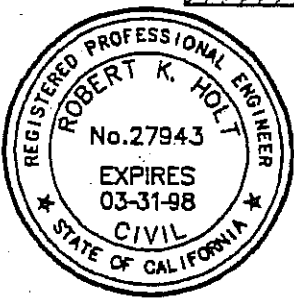
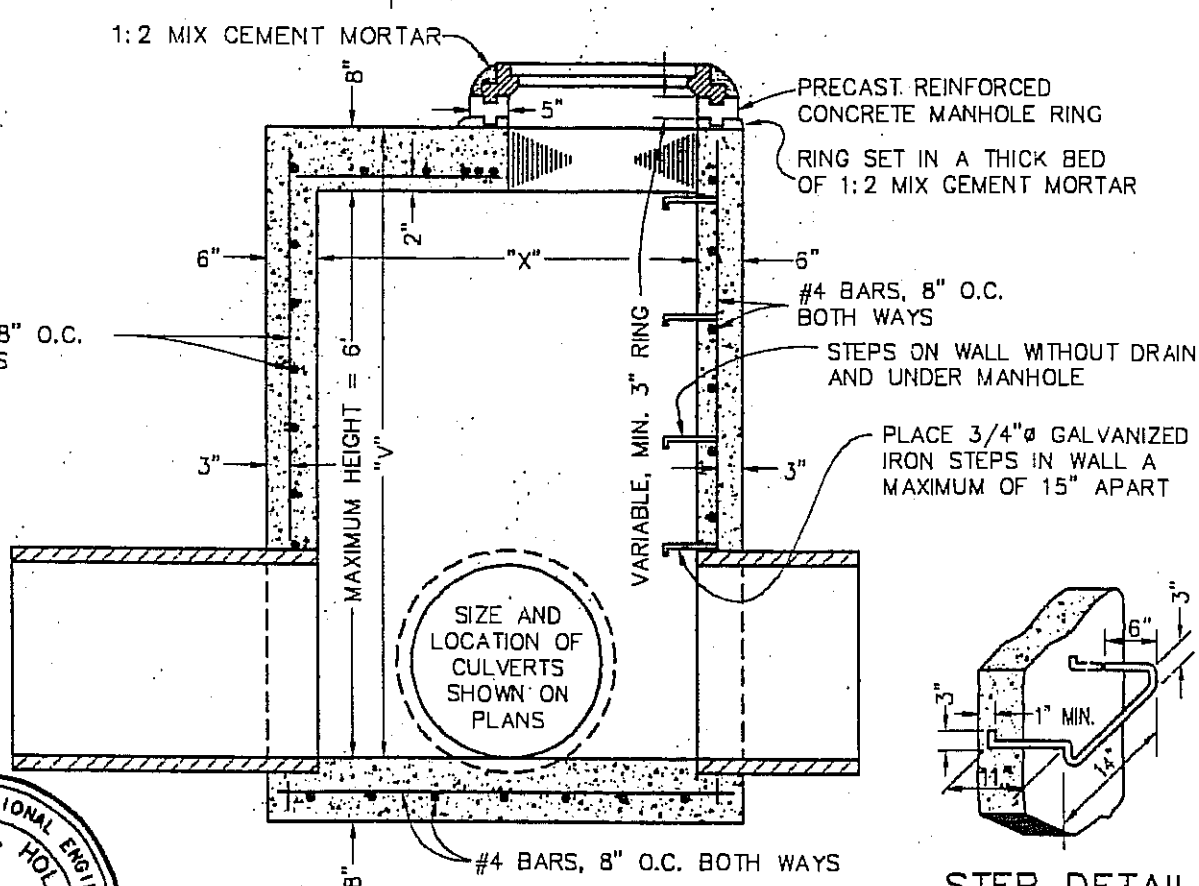
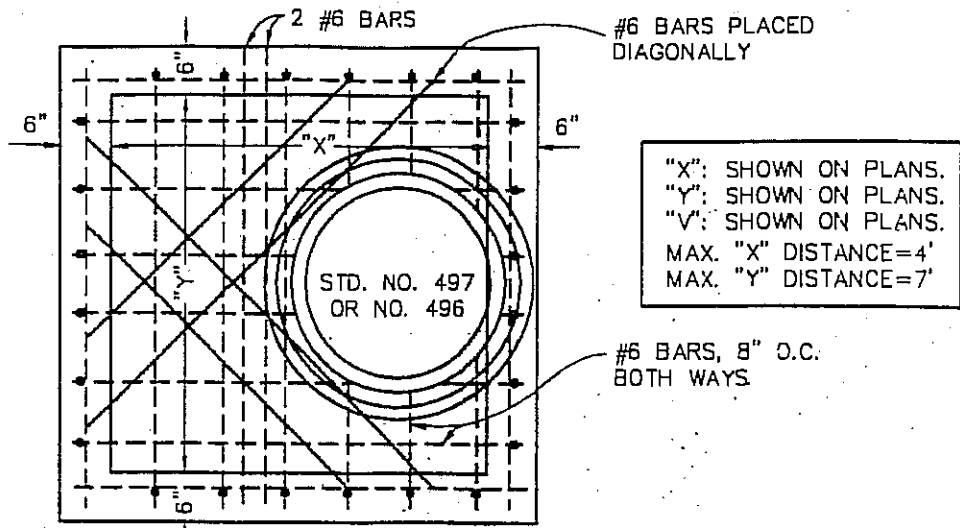

NOTES:

1. STORM DRAIN CLEANOUT SHALL BE CONSTRUCTED OF CLASS "A" CONCRETE.
2. CLEARANCE FROM I.D. OF PIPE TO CLEANOUT WALL SHALL BE 4" MIN.
3. APPROVED PRECAST CONCRETE MANHOLE SHAFT RINGS WILL BE ACCEPTED IN LIEU OF CAST-IN-PLACE SHAFT.

APPROVED:

DATE

APPROVED: TOWN ENGINEER

Robert K. Holt

R.C.E. 27943



Town of
Yucca Valley

STORM DRAIN
CLEANOUT

REVISION

BY DATE

STANDARD DRAWING NO. 462

24" DIA. MANHOLE FRAME AND GRATE
ALHAMBRA # A-1200 OR APPROVED
EQUAL.

1" DIA. HOLE W/ MIRAFI
FABRIC BACKING
AS SHOWN

CAP DETAIL

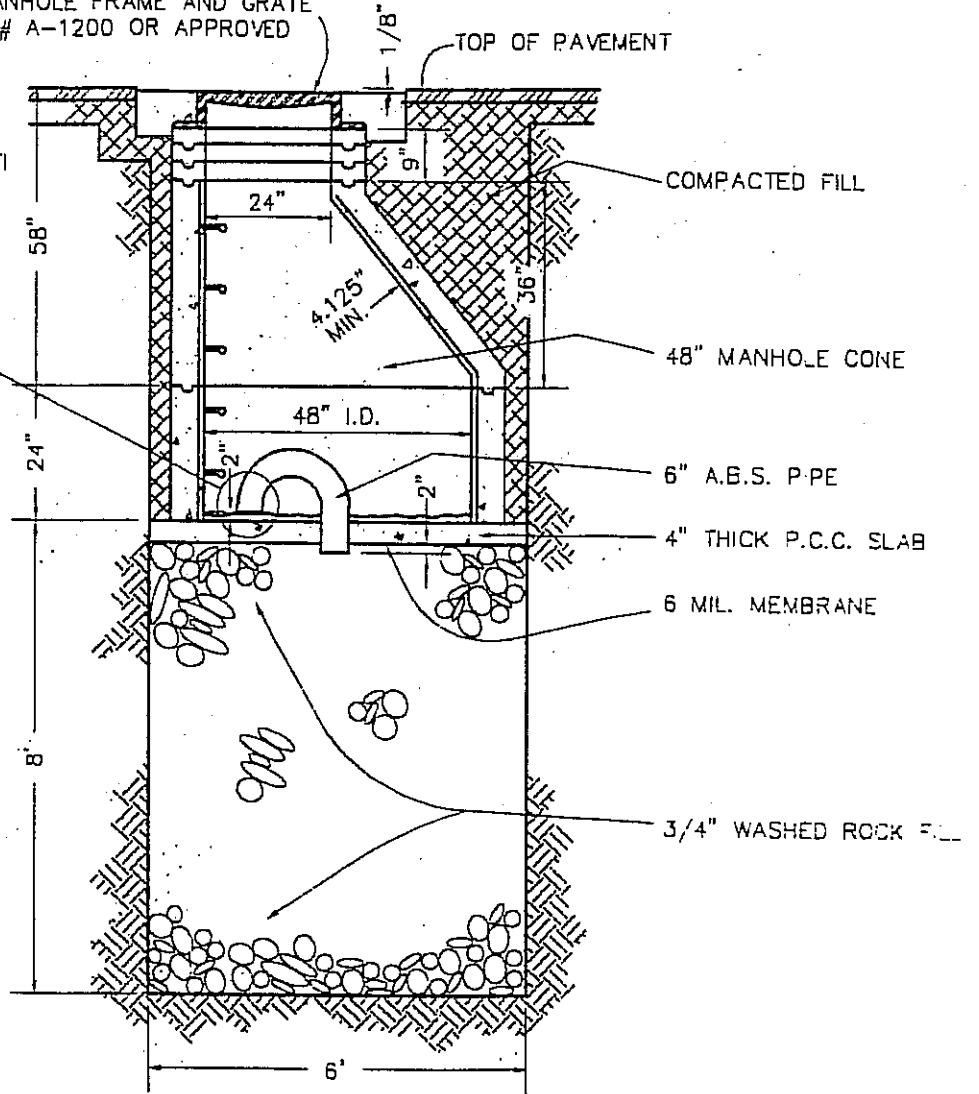

NOTES:

1. PRECAST REINFORCED CONCRETE MANHOLE PIPE TO MEET REQUIREMENTS OF ASTM C 478 SPECIFICATIONS WITH INCREASES IN REINFORCEMENT AND WALL THICKNESS TO MEET LOCAL REQUIREMENTS. MINIMUM COMPRESSIVE STRENGTH OF CONCRETE SHALL BE 4000 P.S.I. AT 28 DAYS.
2. DRYWELL DIMENSIONS AND LOCATION SHALL BE VERIFIED BY A LICENSED SOILS ENGINEER.
3. FINAL DESIGN IS SUBJECT TO APPROVAL BY THE TOWN ENGINEER.

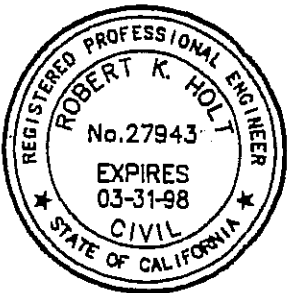

APPROVED:

DATE _____

APPROVED: TOWN ENGINEER

Robert K. Holt

R.C.E. 27943



*Town of
Yucca Valley*

STANDARD DRY WELL

STANDARD DRAWING NO. 463

REVISION

BY DATE

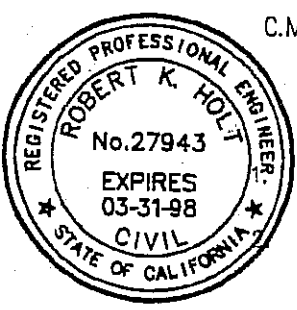
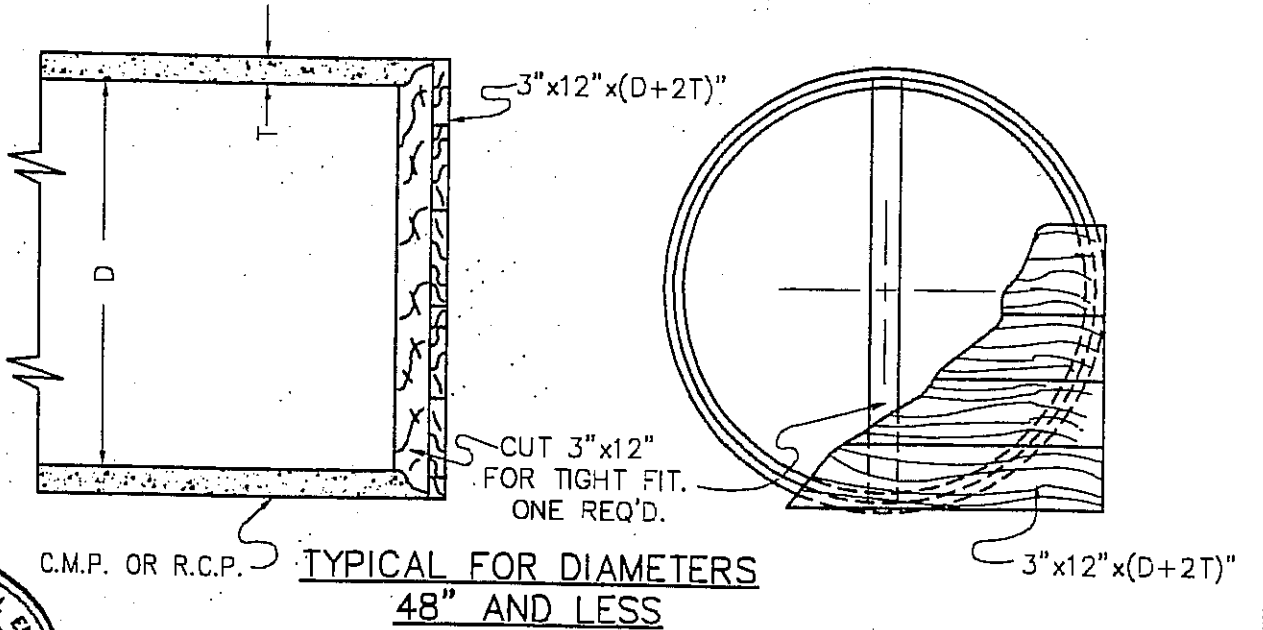
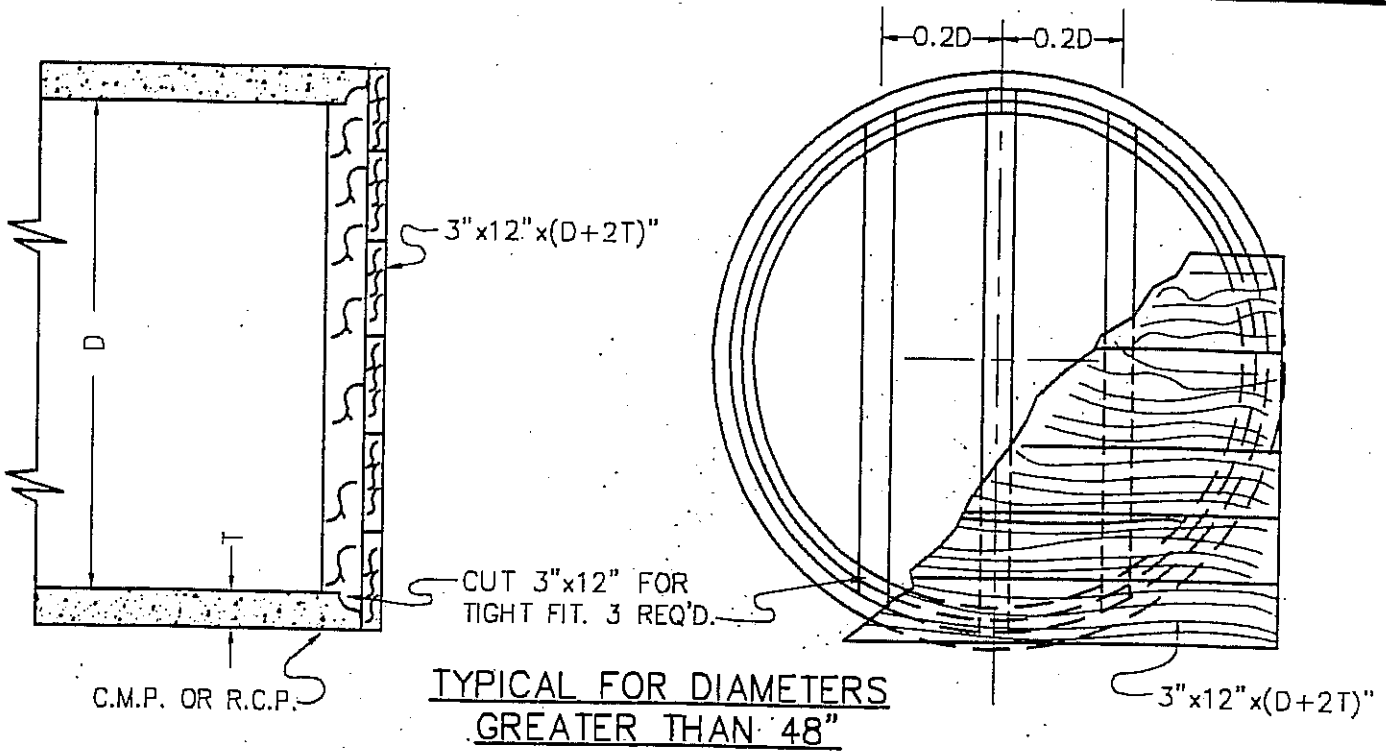

NOTES:

1. NAIL 3" x 12" TO VERTICAL SUPPORTS WITH 40d GALV. NAILS 3" O.C.
2. ALL LUMBER SHALL BE CREOSOTED DOUGLAS FIR, 1500 f CONSTRUCTION GRADE.

APPROVED: _____ DATE _____

APPROVED: TOWN ENGINEER
Robert K. Holt
 R.C.E. 27943

REVISION	BY	DATE



Town of
Yucca Valley

TIMBER BULKHEADS

STANDARD DRAWING NO. 464

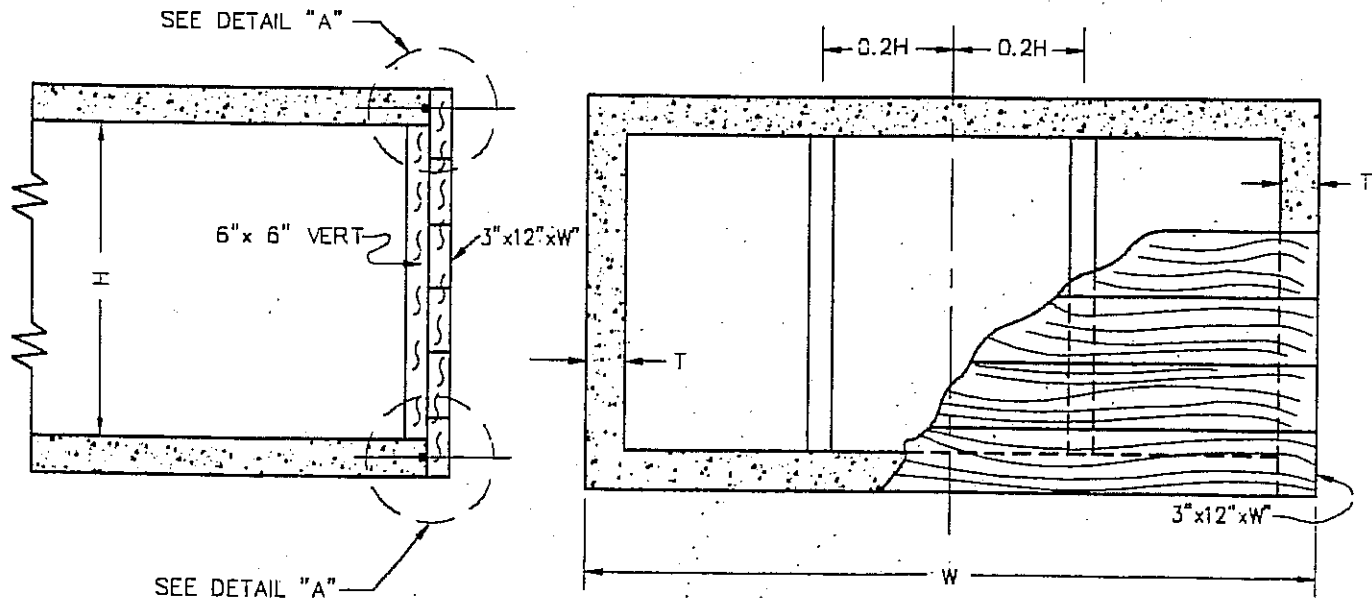

SEE DETAIL "A"

NOTES:

1. NAIL 3" x 12" TO VERTICAL SUPPORTS WITH 40d GALV. NAILS 3" C.C.
2. ALL LUMBER SHALL BE CREOSOTED DOUGLAS FIR, 1500 f CONSTRUCTION GRADE.

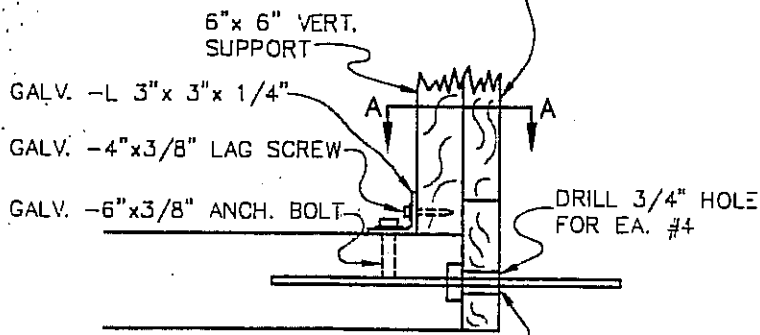
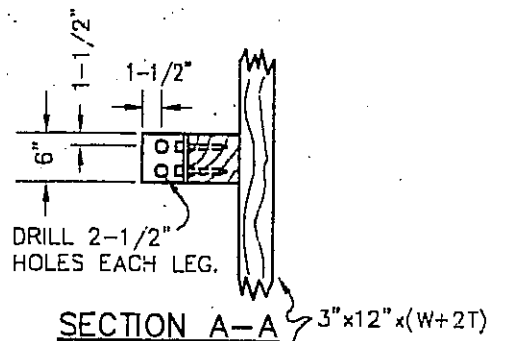

KEYED CONST. JOINT
#4 @ 12"-3' LONG WITH
EXPOSED ENDS HEAVILY
GREASED.

DETAIL A



APPROVED: _____ DATE _____

APPROVED: TOWN ENGINEER
Robert K. Holt R.C.E. 27943



*Town of
Yucca Valley*

TIMBER BULKHEADS

STANDARD DRAWING NO. 465

REVISION BY DATE

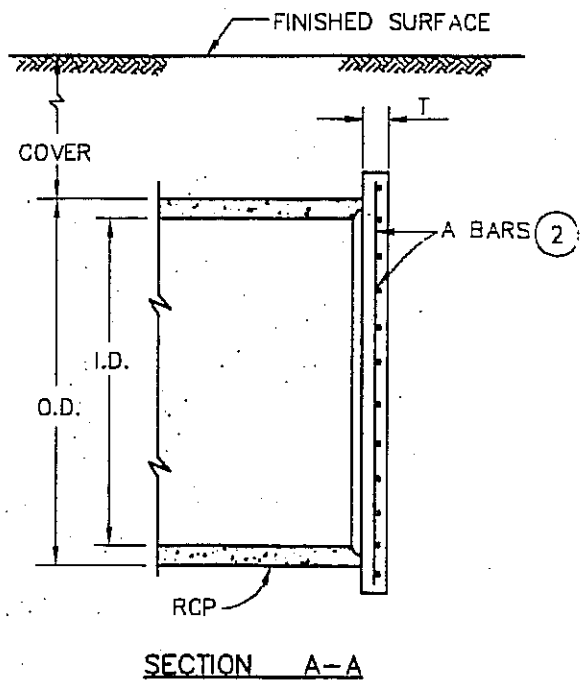
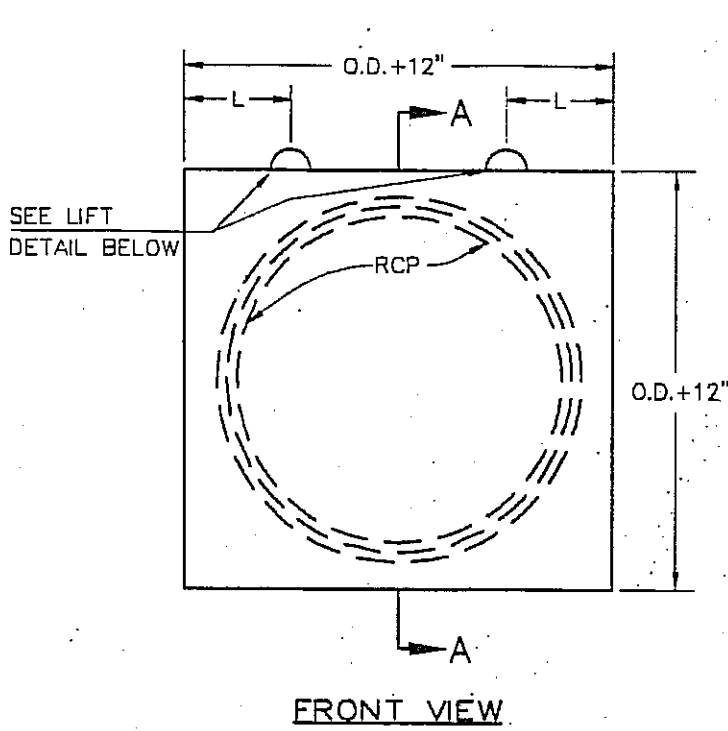

FRONT VIEW

SECTION A-A

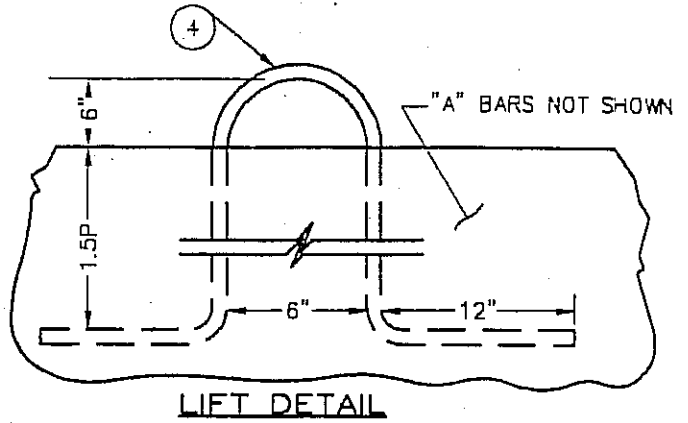

LIFT DETAIL

I.D. (IN.)	MAX COVER (FT.)	T (IN.)	A BARS	L.P.
48-51	5	4	4 @ 9	1'-6"
	10	4	4 @ 6	
	15	5	4 @ 6	
54-60	5	4	4 @ 6	1'-8"
	10	5	4 @ 6	
	15	5	5 @ 6	
63-66	5	5	4 @ 6	1'-10"
	10	5	5 @ 6	
	15	5	5 @ 6	
69-72	5	5	4 @ 6	2'-0"
	10	5	5 @ 6	
	15	5	6 @ 6	
75-78	5	5	5 @ 6	2'-2"
	10	5	6 @ 6	
	15	6	6 @ 6	
81-84	5	5	6 @ 6	2'-4"
	10	5	6 @ 6	
	15	6	6 @ 5	
87-9D	5	5	6 @ 6	2'-5"
	10	6	6 @ 6	
	15	6	6 @ 5	
93-96	5	5	6 @ 6	2'-7"
	10	6	6 @ 5	
	15	6	7 @ 6	

- NOTES:
1. CONCRETE SHALL BE CLASS "B".
 2. REINFORCING STEEL SHALL BE CENTERED IN BULKHEAD WITH HORIZONTAL "A" BARS TOWARDS OUTSIDE FACE OF BULKHEAD.
 3. WHERE CONCRETE BULKHEAD IS USED WITH RCB, T & "A" BARS SHALL BE DETERMINED BY THE HEIGHT OF THE R.C.B.
 4. LIFTS SHALL BE WOVEN STEEL CABLE WITH SAME MIN. DIAMETER (d) AS "A" BARS. WEAVE CABLE THROUGH HORIZONTAL "A" BARS. COAT EXPOSED PORTION OF CABLE LIFTS WITH AN APPROVED BITUMINOUS PAINT PRIOR TO BACKFILLING TRENCH.

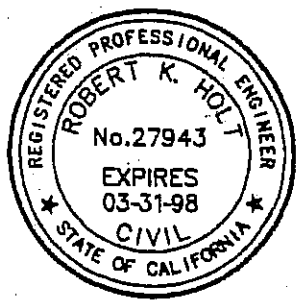

APPROVED: _____ DATE _____

APPROVED: TOWN ENGINEER
Robert K. Holt R.C.E. 27943

REVISION	BY	DATE



Town of
Yucca Valley

CONCRETE BULKHEAD

STANDARD DRAWING NO. 466

SEE STANDARD DWG. 483
MANHOLE FRAME AND COVER FOR CATCH BASINS.

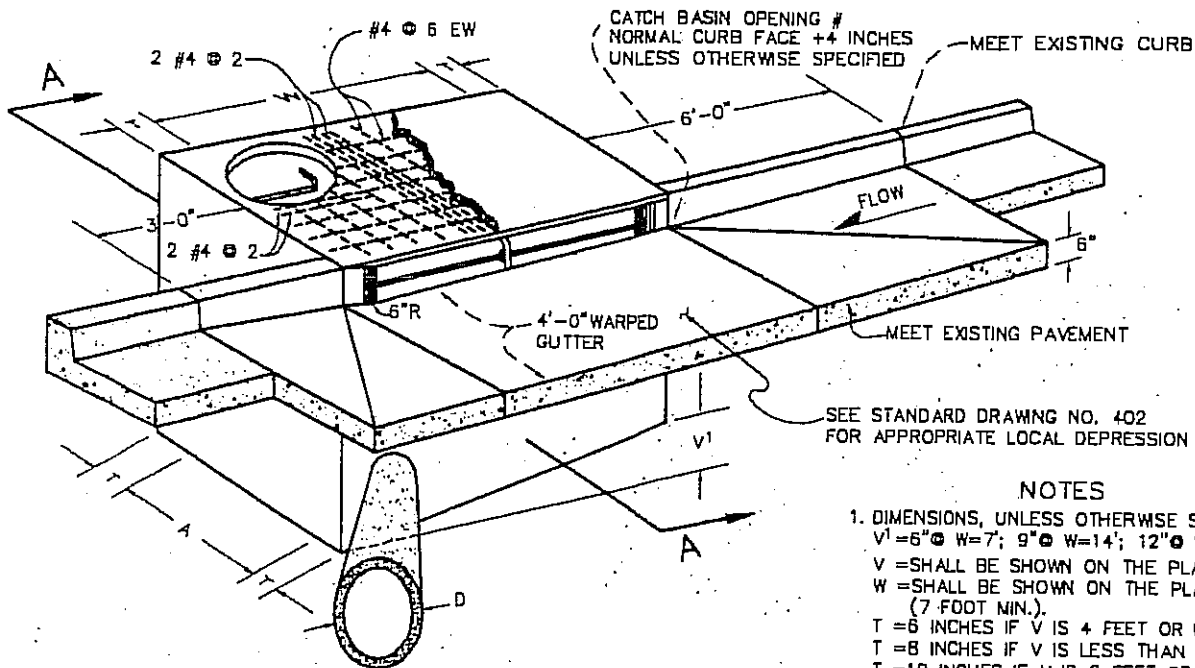

**PERSPECTIVE OF
CATCH BASIN NO. 1**

SEE STD. DWGS. 481 & 481A CATCH BASIN INLET FOR DETAILS.

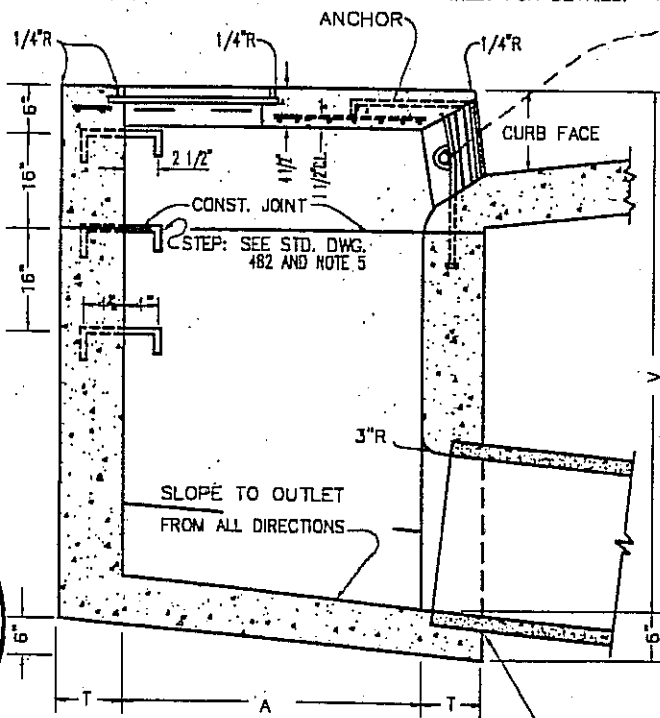

SECTION A-A

SEE STANDARD DRAWING NO. 402
FOR APPROPRIATE LOCAL DEPRESSION

NOTES

- DIMENSIONS, UNLESS OTHERWISE SPECIFIED:
V¹ = 6" @ W=7'; 9" @ W=14'; 12" @ W=21'
V = SHALL BE SHOWN ON THE PLANS
W = SHALL BE SHOWN ON THE PLANS (7 FOOT MIN.).
T = 6 INCHES IF V IS 4 FEET OR LESS.
T = 8 INCHES IF V IS LESS THAN 8 FEET.
T = 10 INCHES IF V IS 8 FEET OR MORE.
D = 18 INCHES UNLESS OTHERWISE SPECIFIED.
A = 38 INCHES UNLESS OTHERWISE SPECIFIED.
- STRUCTURAL CONCRETE SHALL BE CLASS "A" P.C.C. (6 SACK).
- THE REINFORCING STEEL SHALL BE NUMBER 4 DEFORMED BARS. CLEARANCE SHALL BE 1 1/2 INCH FROM THE BOTTOM OF THE SLAB. SEE NOTE 7.
- THE SURFACE OF ALL EXPOSED CONCRETE SHALL CONFORM TO SLOPE, GRADE, COLOR, FINISH AND SCORING IN THE EXISTING OR PROPOSED CURB AND WALK ADJACENT TO THE BASIN. THE BASIN FLOOR SHALL BE GIVEN A TIGHT WOOD FLOAT FINISH. CURVATURE OF THE LIP AND SIDEWALKS AT THE GUTTER OPENING SHALL NOT BE MADE BY PLASTERING. THE OUTLET PIPE SHALL BE TRIMMED TO FINAL SHAPE AND LENGTH BEFORE THE CONCRETE IS POURED.
- STEPS:
3/4 INCH PLAIN ROUND GALVANIZED STEEL STEPS SHALL BE INSTALLED 16 INCHES APART WHEN V EXCEEDS 4 FEET 6 INCHES. THE TOP STEP SHALL BE 6 INCHES BELOW THE TOP SURFACE AND SHALL BE 2 1/2 INCHES CLEAR FROM THE WALL. ALL OTHER STEP SHALL BE 4 INCHES CLEAR FROM THE WALL. ONLY ONE STEP 12 INCHES FROM THE BOTTOM SHALL BE INSTALLED IF V IS 4 FEET 6 INCHES OR LESS. ALL STEPS SHALL BE ANCHORED NOT LESS THAN 4 INCHES INTO THE WALL OF THE BASIN.
- CURB, GUTTER AND LOCAL DEPRESSIONS SHALL BE CLASS "B" CONCRETE.
- SEE STANDARD DRAWING 473 FOR WALL & FLOOR STEEL REINFORCING.



APPROVED:

DATE

APPROVED: TOWN ENGINEER

Robert K. Holt

R.C.E. 27943



Town of
Yucca Valley

CATCH BASIN
NO. 1

REVISION

BY DATE

STANDARD DRAWING NO. 470

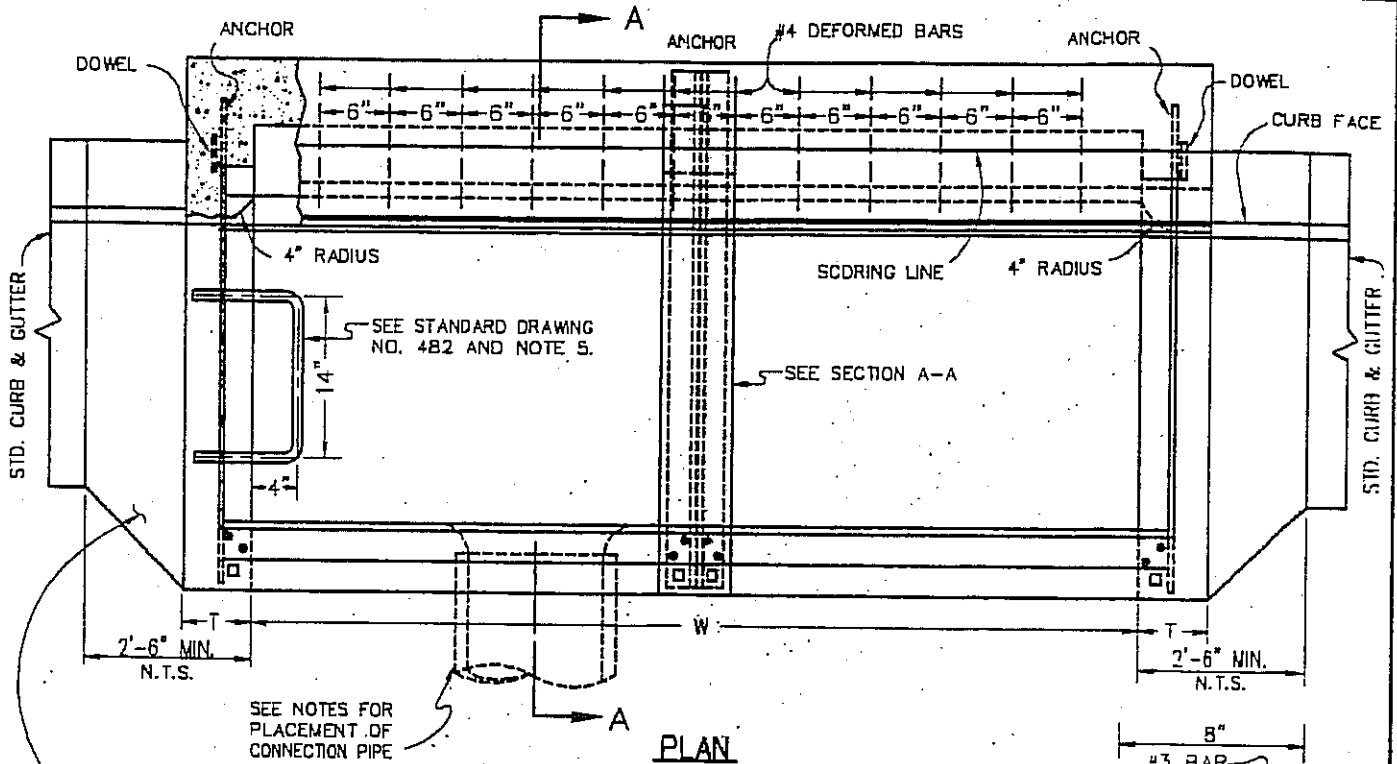

SEE STANDARD DRAWING NO. 403
NOTE 1(a) FOR APPROPRIATE LOCAL
DEPRESSION.

SEE NOTES FOR
PLACEMENT OF
CONNECTION PIPE

PLAN

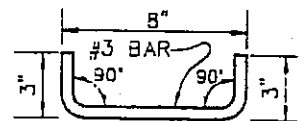

DETAIL OF DOWEL

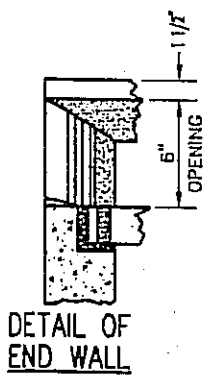

DETAIL OF
END WALL

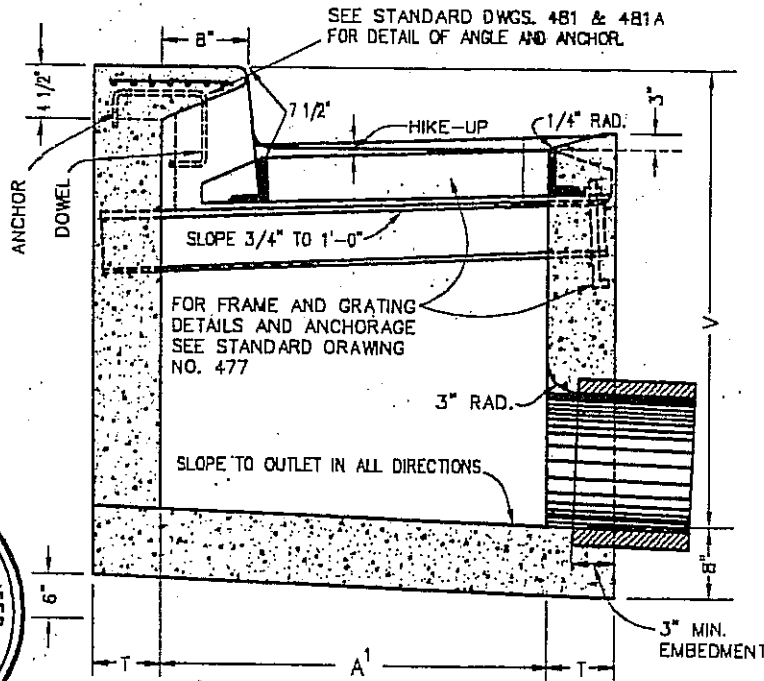

SECTION-AA

STEEL LIST					
NO. OF GRATINGS	#4 DEF. BARS 11" LONG	5/16" x 10" FACE PLATE	DOWELS	ANCHORS	3/4" GALV. STEEL STEPS
1	5	5-11 1/2"	2	2	SEE NOTES
2	12	7-4 3/4"	2	3	
3	19	10-10 1/2"	2	4	

A ¹	GRATE TYPE
34"	R.C.F.C. STD. CB104
32"	CALTRANS STD. D77-B

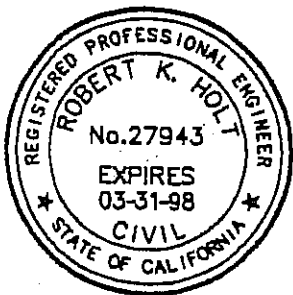

APPROVED:

DATE _____

APPROVED: TOWN ENGINEER

Robert K. Holt

R.C.E. 27943



Town of
Yucca Valley

CATCH BASIN
NO. 4

SHT. 1 OF 2

STANDARD DRAWING NO. 471

REVISION

BY DATE

NOTES FOR CATCH BASIN NO. 4

1. DIMENSIONS: UNLESS OTHERWISE SPECIFIED.

V = 3.5 FEET.

T = 6 INCHES, IF V IS 4 FEET OR LESS.

T = 8 INCHES, IF V IS BETWEEN 4 FEET AND 8 FEET.

T = 10 INCHES, IF V IS 8 FEET OR OVER.

W = 2 FEET, 11-3/8 INCHES FOR ONE GRATING.

ADD 3 FEET, 5-3/8 INCHES FOR EACH ADDITIONAL GRATING.

HIKE-UP SHALL BE PARALLEL TO PLANE OF GUTTER - SLOPE 3/4 INCH TO 1 FOOT.

SLOPE OF FLOOR PARALLEL WITH CURB SHALL BE 1 IN 12.

S = 1-1/2 INCHES.

R = 3/4 INCH.

2. CONCRETE SHALL BE CLASS "A" PORTLAND CEMENT CONCRETE (6.0 SACK)

3. THE REINFORCING STEEL SHALL BE NUMBER 4 DEFORMED BARS. CLEARANCE SHALL BE 1-1/2 INCHES FROM TOP SLAB. SEE STD. DWG. 473 AND NOTE 3.

4. THE SURFACE OF ALL EXPOSED CONCRETE SHALL CONFORM TO SLOPE, GRADE, COLOR, FINISH, AND SCORING IN THE EXISTING OR PROPOSED CURB AND WALK ADJACENT TO THE BASIN. THE BASIN FLOOR SHALL BE GIVEN A TIGHT WOOD FLOAT FINISH. CURVATURE OF THE LIP AND SIDEWALLS AT THE GUTTER OPENING SHALL NOT BE MADE BY PLASTERING. THE OUTLET PIPE SHALL BE TRIMMED TO FINAL SHAPE AND LENGTH BEFORE THE CONCRETE IS POURED.

5. STEPS: 3/4 INCH PLAIN ROUND GALVANIZED STEEL STEPS ARE REQUIRED AS FOLLOWS:

IF V IS 4.5 FEET OR LESS, NO STEPS ARE REQUIRED.

IF V IS MORE THAN 4.5 FEET, AND NOT MORE THAN 5.0 FEET, INSTALL ONE STEP 12 INCHES ABOVE FLOOR OF BASIN.

IF V IS MORE THAN 5.0 FEET, INSTALL STEPS 16 INCHES APART WITH THE TOP STEP 6 INCHES BELOW THE TOP OF GRATING.

ALL STEPS SHALL BE 4 INCHES CLEAR FROM THE WALL AND ANCHORED NOT LESS THAN 4 INCHES INTO THE WALL OF THE BASIN.

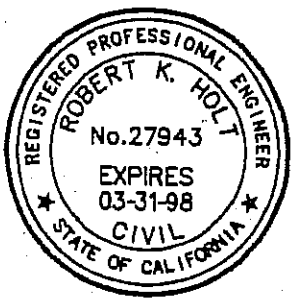

APPROVED:

DATE

APPROVED: TOWN ENGINEER

Robert K. Holt

R.C.E. 27943



Town of
Yucca Valley

CATCH BASIN

NO. 4

SHT. 2 OF 2

REVISION

BY DATE

STANDARD DRAWING NO. 471A

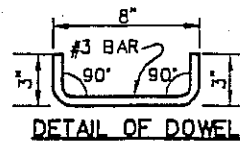
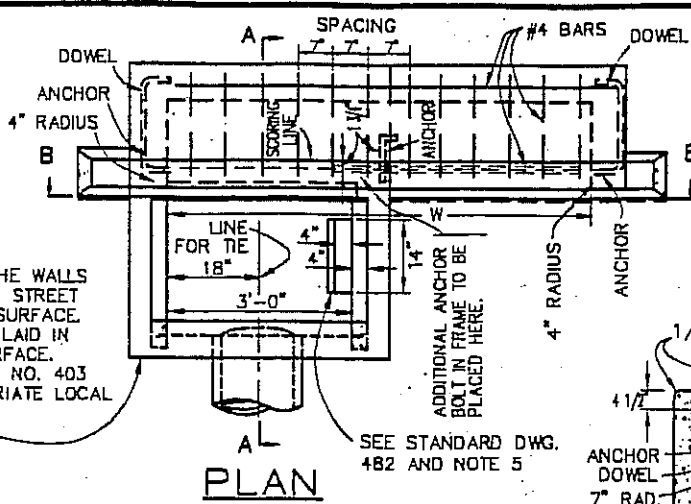

THE OUTER EDGES OF THE WALLS SHALL CONFORM TO THE STREET OR LOCAL DEPRESSION SURFACE. THE GRATING SHALL BE LAID IN THE PLANE OF THIS SURFACE. SEE STANDARD DRAWING NO. 403 NOTE 1(b) FOR APPROPRIATE LOCAL DEPRESSION.

SEE STANDARD DWG. 482 AND NOTE 5

PLAN

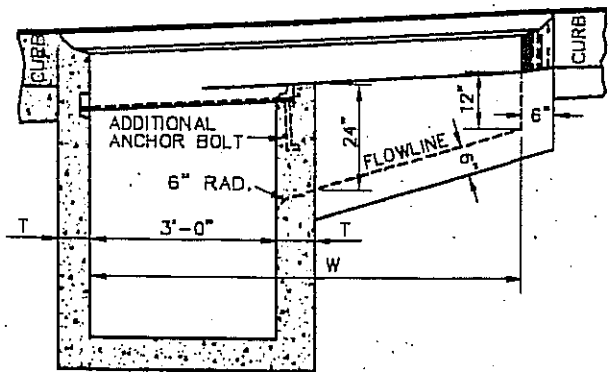

SECTION B-B

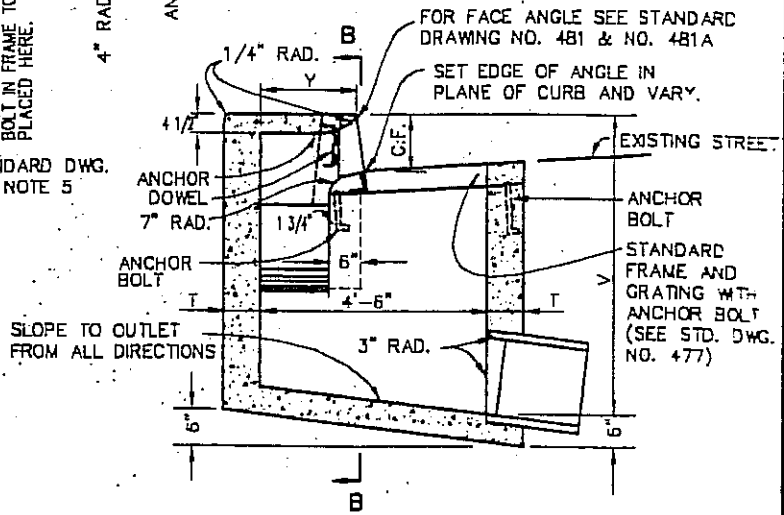

SECTION A-A

NOTES:

- DIMENSIONS: UNLESS OTHERWISE SPECIFIED, V = 4.5 FEET. W = 7.0 FEET.
 T = 6 INCHES IF V IS 5 FEET OR LESS. T = 8 INCHES IF V IS BETWEEN 5 FT. & 8 FEET.
 T = 10 INCHES IF V IS 8 FEET OR MORE. Y = 2 FEET 3 INCHES.
- CONCRETE SHALL BE CLASS "A" PORTLAND CEMENT CONCRETE (6.0 SACK).
- THE REINFORCING STEEL SHALL BE NUMBER 4 DEFORMED BARS. CLEARANCE SHALL BE 1 1/2" FROM THE BOTTOM OF THE SLAB. SEE STANDARD DRAWING 473 - NOTE 3.
- THE SURFACE OF ALL EXPOSED CONCRETE SHALL CONFORM TO THE SLOPE, GRADE, COLOR, FINISH, AND SCORING IN THE EXISTING OR PROPOSED CURB AND WALK ADJACENT TO THE BASIN. THE BASIN FLOOR SHALL BE GIVEN A TIGHT WOOD FLOAT FINISH. CURVATURE OF THE LIP AND SIDE WALLS AT THE GUTTER OPENING SHALL NOT BE MADE BY PLASTERING. THE OUTLET PIPE SHALL BE TRIMMED TO FINAL SHAPE AND LENGTH BEFORE THE CONCRETE IS POURED.
- STEPS: 3/4 INCH PLAIN ROUND GALVANIZED STEEL STEPS SHALL BE INSTALLED 16 INCHES APART WHEN V EXCEEDS 4 FEET 6 INCHES. THE TOP STEP SHALL BE 6 INCHES BELOW THE TOP SURFACE AND SHALL BE 2 1/2 INCHES CLEAR FROM THE WALL. ALL OTHER STEPS SHALL BE 4 INCHES CLEAR FROM THE WALL. ONLY ONE STEP 12 INCHES FROM THE BOTTOM SHALL BE INSTALLED IF V IS 4 FEET 6 INCHES OR LESS. ALL STEPS SHALL BE ANCHORED NOT LESS THAN 4 INCHES INTO THE WALL OF THE BASIN.

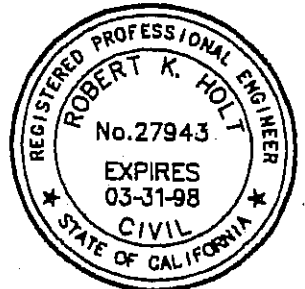

APPROVED: _____ DATE _____

APPROVED: TOWN ENGINEER
Robert K. Holt R.C.E. 27943



Town of
Yucca Valley

CATCH BASIN NO. 6

STANDARD DRAWING NO. 472

REVISION	BY	DATE

NOTES

1. WALL & FLOORING REINFORCING SHOWN HEREON SHALL BE USED WITH CATCH BASIN STANDARD DRAWINGS.
2. REINFORCING STEEL SHOWN HEREON SHALL BE USED IN ALL CATCH BASINS ON STATE HIGHWAYS REGARDLESS OF BASIN LENGTH OR DEPTH.
3. PROVIDE WALL & FLOOR STEEL REINFORCING WHEN THE FOLLOWING "V" DEPTHS ARE EQUALED OR EXCEEDED:

BASIN LENGTH=W	BASIN DEPTH=V
TO 7.0'	10'
7' TO 14.0'	7'
14' TO 21.0'	6'
OVER 21.0'	ALL DEPTHS

REINFORCING STEEL SHOWN HEREON SHALL BE USED IN ALL CATCH BASINS WHEN EXCAVATION OR SOIL CONDITIONS REQUIRE BOTH SIDES OF THE WALLS TO BE FORMED REGARDLESS OF BASIN LENGTH OR DEPTH.

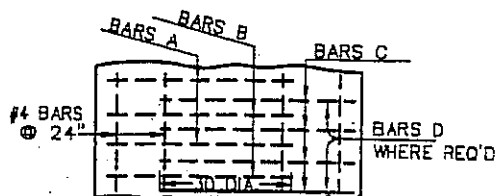

FLOOR REINFORCEMENT SECTION 2

W OF C.B.	V (FT.)		T (IN)	FRONT WALL STEEL		REAR & END WALLS & FLOOR STEEL
	FROM	TO (INCL)		HOR.	VERT.	EACH WAY
TD 7'		4	6	#3 @ 6"	#3 @ 6"	# 3 @ 6"
TD 7'	4	8	8	#4 @ 12"	#4 @ 12"	# 4 @ 12"
TD 7'	8	12	10	#4 @ 10"	#4 @ 10"	# 4 @ 10"
14'		4	6	#3 @ 6"	#3 @ 6"	# 3 @ 6"
14'	4	8	8	#4 @ 12"	#4 @ 12"	# 4 @ 12"
14'	8	10	10	#4 @ 8"	#4 @ 12"	# 4 @ 10"
14'	10	12	10	#4 @ 6"	#4 @ 12"	# 4 @ 10"

WALL AND FLOOR STEEL

CATCH BASIN REINFORCEMENT--"W" TO 14'(INCL.)

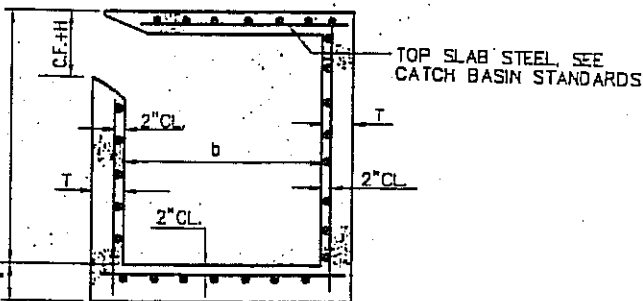

SECTION 1

V (FT.)	T (IN)		FRONT WALL STEEL	REAR WALL STEEL	END WALL STEEL
	FROM	TO (INCL)	BAR A & B	BARS C	BARS D
4	4	6	# 3 @ 24"	#3 @ 12"	----
4	5	8	# 3 @ 20"	#3 @ 12"	----
5	6	8	# 3 @ 12"	#3 @ 10 1/2"	----
6	7	8	# 4 @ 17"	#3 @ 8 1/2"	----
7	8	8	# 4 @ 13"	#3 @ 6 1/2"	----
8	9	10	# 4 @ 15"	#3 @ 7 1/2"	----
9	10	10	# 4 @ 12"	#4 @ 12"	----
10	11	10	# 5 @ 15"	----	#4 @ 11"
11	12	10	# 6 @ 18"	----	#4 @ 9"
X=(V+T)-(C.F.+H+4 1/2")			Y= (X-21)+15 DIA.-2"		

WALL AND FLOOR STEEL

CATCH BASIN REINFORCEMENT--"W" GREATER THAN 14'

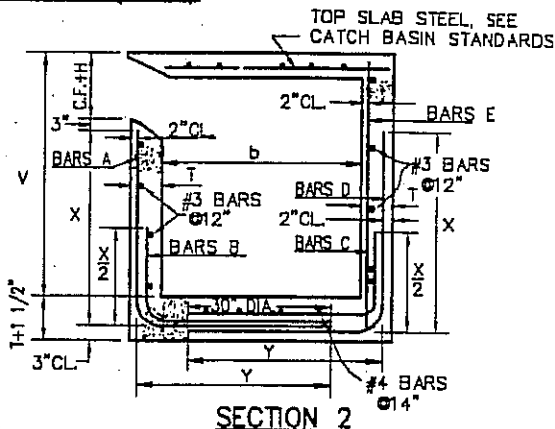

SECTION 2



V (FT.)	T (IN)		SIDE & END WALL STEEL
	FROM	TO (INCL)	BARS G
4	4	6	# 3 @ 6"
4	8	8	# 4 @ 6"
8	8	12	# 5 @ 6"

GRATING BASIN REINFORCEMENT

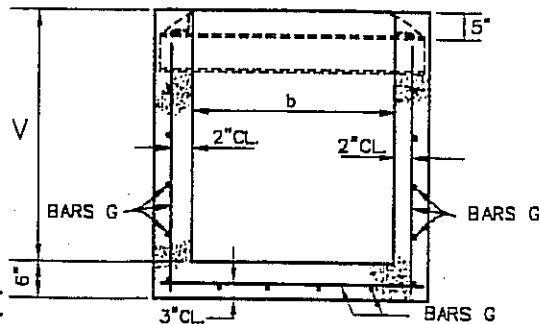

APPROVED:

DATE

APPROVED: TOWN ENGINEER

Robert K. Holt

R.C.E. 27943



Town of
Yucca Valley

CATCH BASIN
REINFORCEMENT

REVISION

BY DATE

STANDARD DRAWING NO. 473

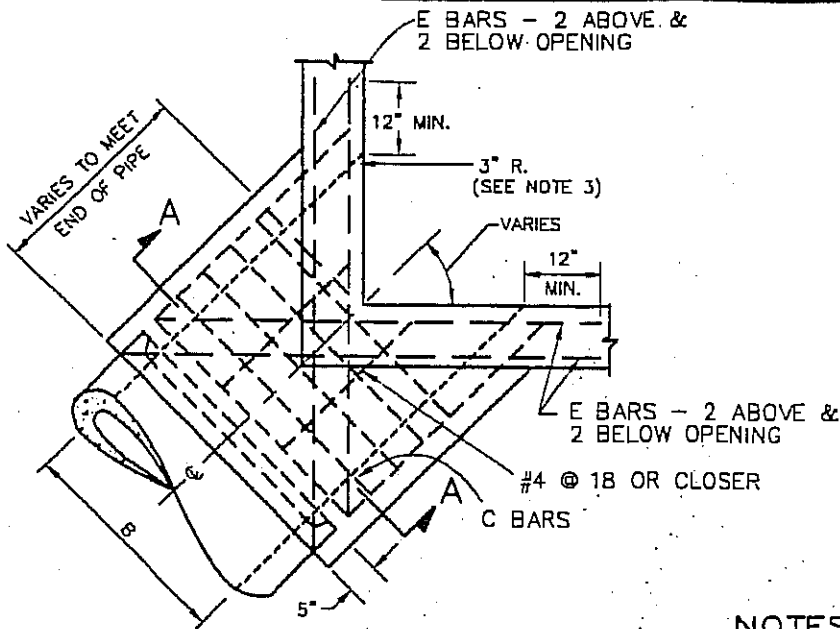

**PLAN
CORNER CONNECTION**

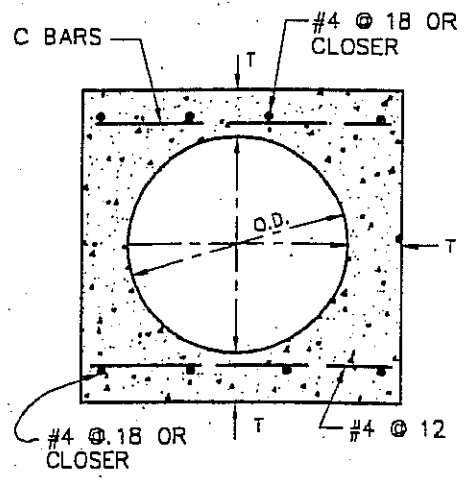

SECTION A-A

NOTES:

1. REINFORCING STEEL SHALL BE 1 1/2" CLEAR FROM INSIDE FACE OF CONCRETE UNLESS OTHERWISE SHOWN.
2. REINFORCING STEEL FOR INSIDE FACE OF CATCH BASIN WALL SHALL BE CUT AT CENTER OF OPENING AND BENT INTO WALLS OF MONOLITHIC CONNECTION. REINFORCING STEEL FOR OUTSIDE FACE OF CATCH BASIN WALL SHALL BE CUT 2" CLEAR OF OPENING.
3. CONNECTION SHALL BE POURED MONOLITHIC WITH CATCH BASIN. THE ROUNDED EDGE OF OUTLET SHALL BE CONSTRUCTED BY POURING CONCRETE AGAINST A CURVED FORM WITH A RADIUS OF 3".
4. FLOOR OF STRUCTURE SHALL BE STEEL-TROWELED TO SPRING LINE.
5. CONNECTIONS SHALL BE CONSTRUCTED WHERE (A.) PIPES, 12 INCHES THROUGH 72 INCHES IN DIAMETER, INLET OR OUTLET THROUGH CORNER OF CATCH BASIN AT AN ANGLE LESS THAN 40° (B.) ANGLE A, FOR PIPES 24 INCHES THROUGH 30 INCHES IN DIAMETER, IS LESS THAN 45°.

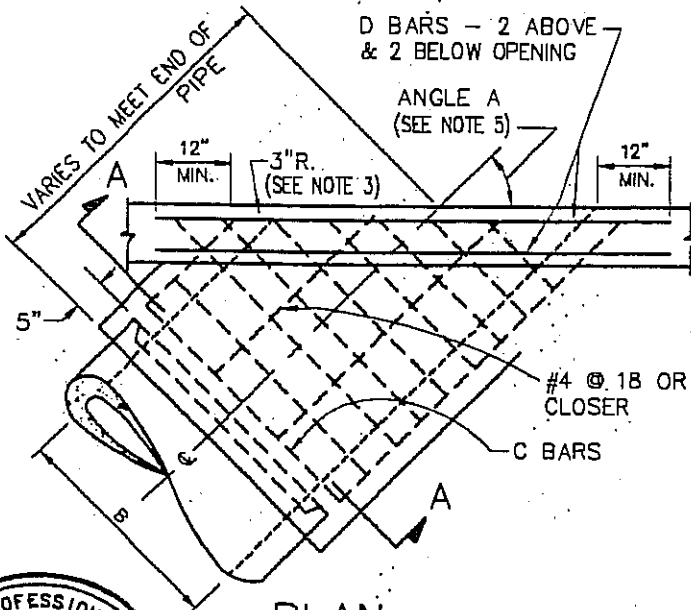

**PLAN
SIDE CONNECTION**

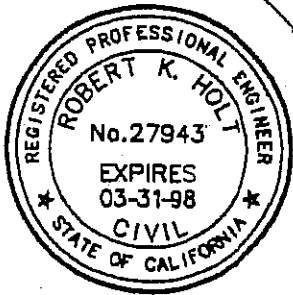

B	T	C BARS	D & E BARS	B	T	C BARS	D & E BARS
12"	4"	#4 @ 6	#5	42"	7 1/2"	#5 @ 6	#6
15"	4 1/4"			45"	7 3/4"		
18"	4 1/2"			48"	8"		
21"	5"			51"	8 1/2"		
24"	5 1/4"			54"	9"		
27"	5 1/2"			57"	9 1/4"		
30"	6"			60"	9 1/2"		
33"	6 1/4"			63"	10"		
36"	6 1/2"			66"	10 1/4"		
39"	7"			69"	10 3/4"		
				72"	1"		

APPROVED:

DATE

APPROVED: TOWN ENGINEER

Robert K. Holt

R.C.E. 27943



*Town of
Yucca Valley*

**SPECIAL CONNECTIONS
TO CATCH BASIN**

REVISION

BY DATE

STANDARD DRAWING NO. 474

"X" (4' MIN.)
 FOR LENGTHS OVER 7' A SUPPORT BOLT SHALL
 BE USED (SEE STANOARD NO. 480)

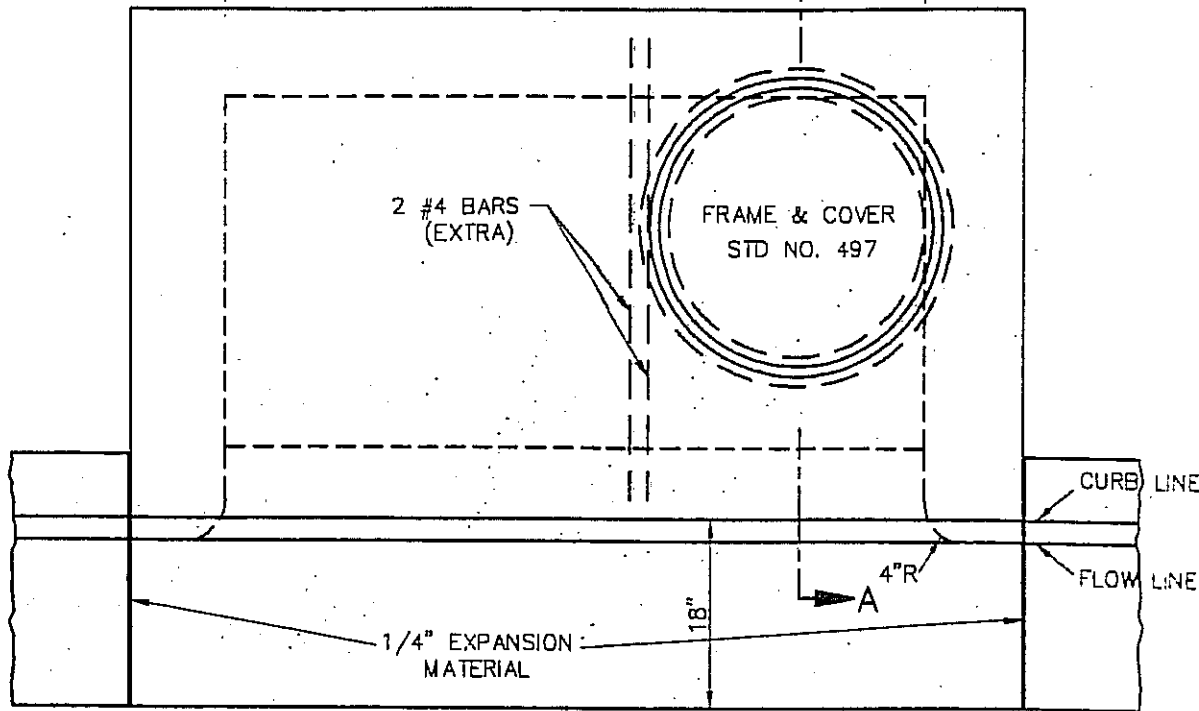

- NOTES:**
1. ALL REINFORCING SHALL BE #4 BARS AT 12" O.C. BOTH WAYS IN TOP SLAB AND WALLS.
 2. CATCH BASIN SHALL BE CONSTRUCTED OF CLASS "A" CONCRETE.
 3. CURB & GUTTER ADJOINING CATCH BASIN SHALL BE CONSTRUCTED PRIOR TO CONSTRUCTING TOP OF CATCH BASIN.

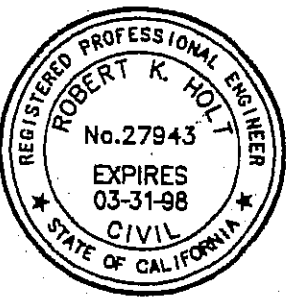
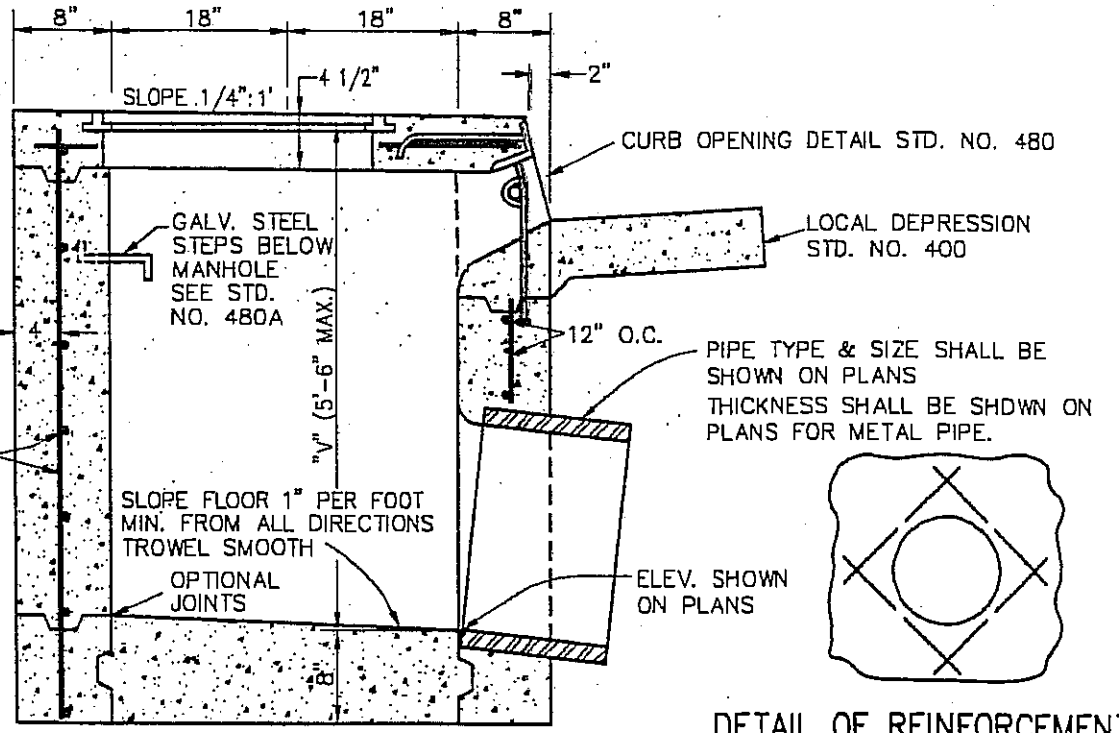

SECTION A-A

DETAIL OF REINFORCEMENT
 AROUND PIPE

APPROVED:	DATE
APPROVED: TOWN ENGINEER <i>Robert K. Holt</i>	R.C.E. 27943
REVISION	BY DATE



Town of
Yucca Valley

TYPE "A"
 CATCH BASIN

STANDARD DRAWING NO. 475

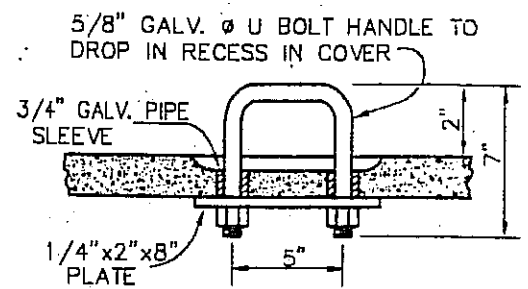
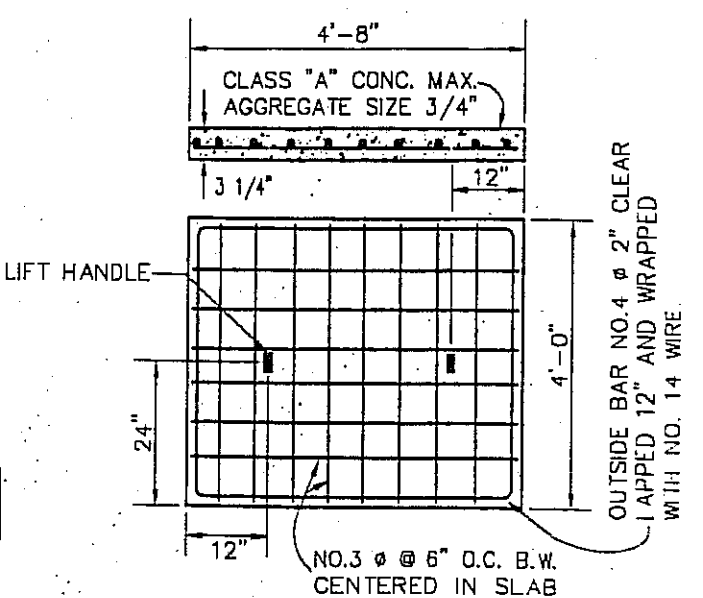
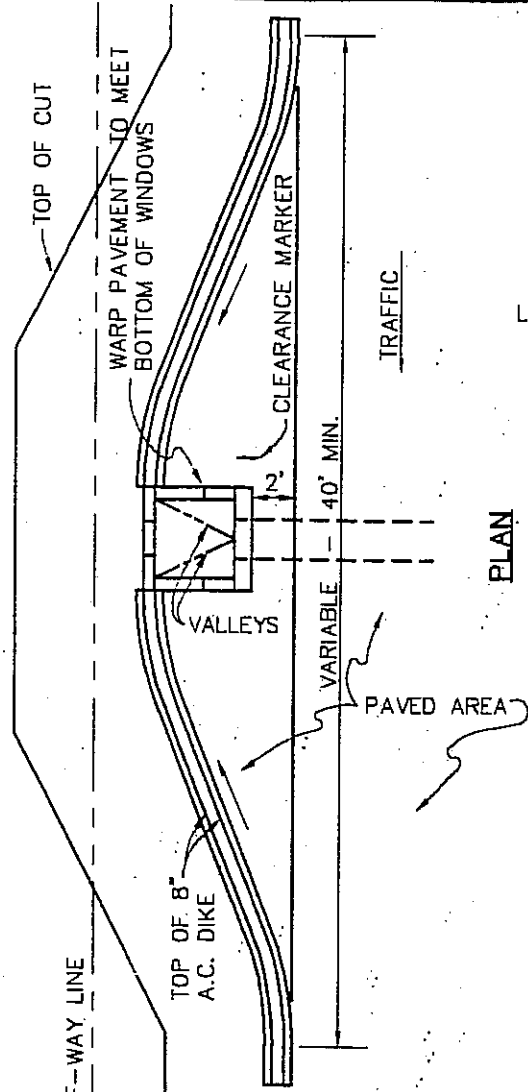

CONC. COVER AND HANDLE DETAIL

VARIABLE - MIN. 40'
 CLEAR R/W OF ALL TREES, STUMPS, BRUSH, ETC. CLEAR SLOPES AND DEDICATE SLOPE RIGHTS. NO BRUSH, STUMPS, ETC., TO BE USED IN FILLS.

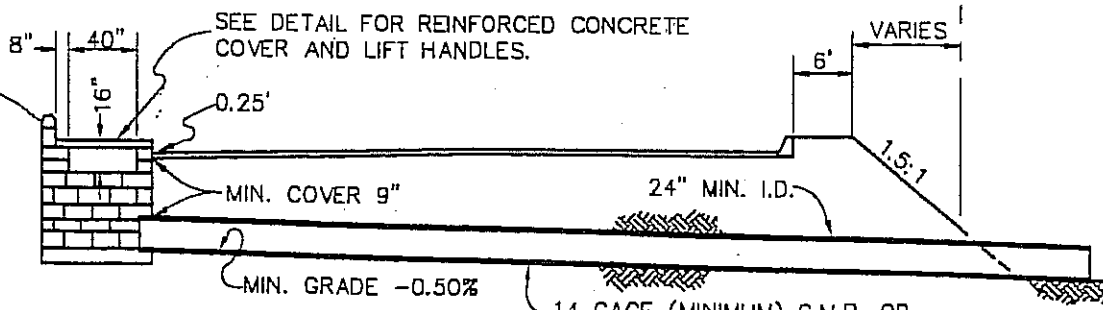

PROFILE 14 GAGE (MINIMUM) C.M.P. OR REINFORCED CONCRETE PIPE (CLASS III)

NOTES:
 FOR CONSTRUCTION DETAILS OF CATCH BASIN SEE STD. NO. 448A.

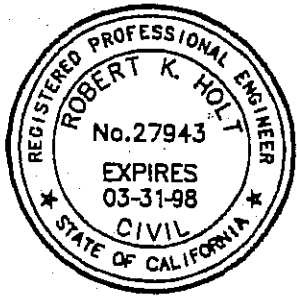

APPROVED:	DATE
APPROVED: TOWN ENGINEER <i>Robert K. Holt</i>	R.C.E. 27943
REVISION	BY DATE



Town of
Yucca Valley

CATCH BASIN
 MOUNTAIN ROADS

STANDARD DRAWING NO. 476

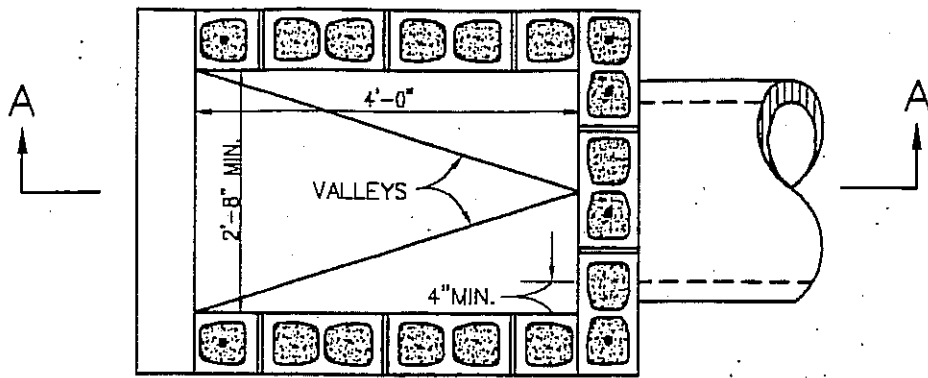

PLAN

CONCRETE CAP ON
BOND BEAM WITH
#3 BAR CONTINUOUS.

SEE STANDARD NO. 476
FOR COVER DETAILS

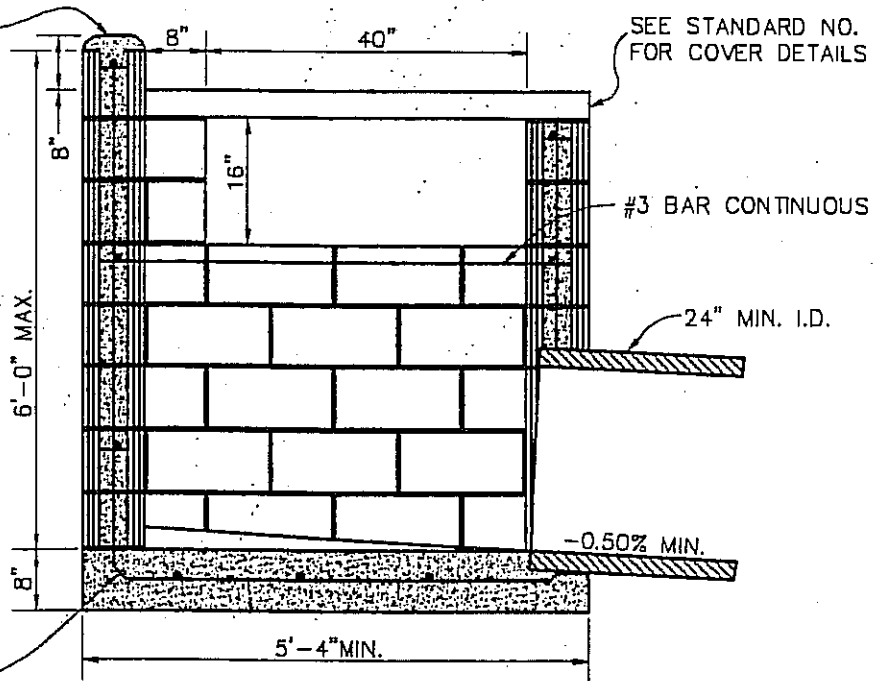

REINFORCEMENTS IN
BASE SHALL BE #3
BARS 16" O.C. BENT
AS VERTICAL DOWELS

SECTION A-A

NOTES:

1. 8"x8"x16" CONC. BLOCK WITH #3 STEEL 16" O.C. VERT. AND 24" O.C. HORIZ.
2. FILL ALL BLOCKS WITH GROUT.
3. BASE OF CATCH BASIN SHALL BE CONSTRUCTED WITH CLASS 'B' CONCRETE.
4. HORIZONTAL STEEL SHALL BE PLACED IN BOND BEAM BLOCKS.

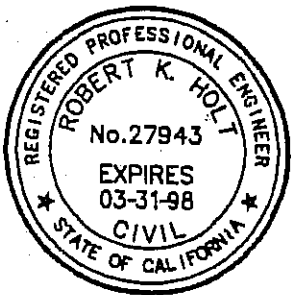

APPROVED:

DATE

APPROVED: TOWN ENGINEER

Robert K. Holt

R.C.E. 27943



Town of
Yucca Valley

CATCH BASIN
MOUNTAIN ROADS

REVISION

BY DATE

STANDARD DRAWING NO. 476A

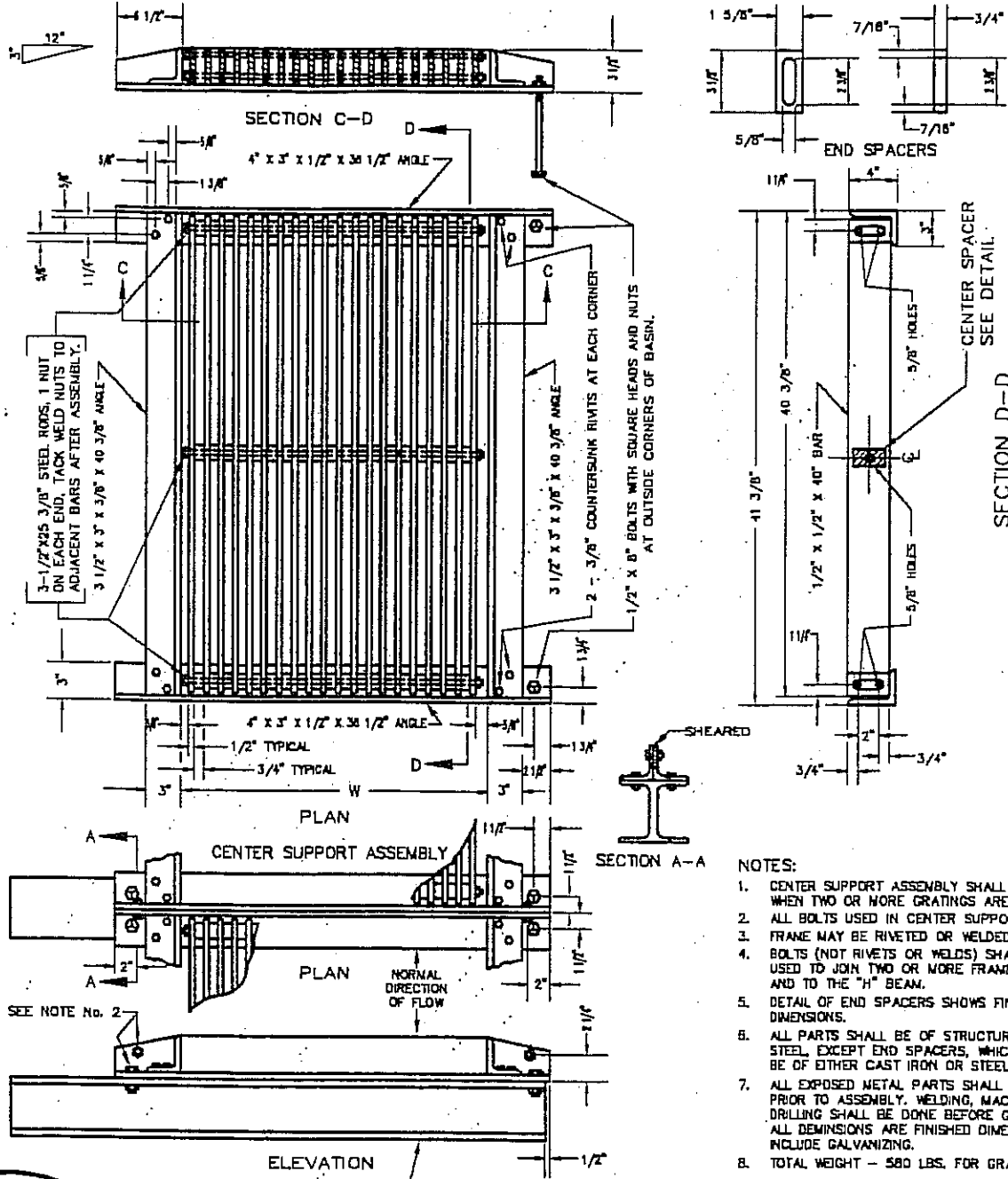

- NOTES:
1. CENTER SUPPORT ASSEMBLY SHALL BE USED WHEN TWO OR MORE GRATINGS ARE SPECIFIED.
 2. ALL BOLTS USED IN CENTER SUPPORT SHALL BE 1/2".
 3. FRAME MAY BE RIVETED OR WELDED.
 4. BOLTS (NOT RIVETS OR WELDS) SHALL BE USED TO JOIN TWO OR MORE FRAMES TOGETHER AND TO THE "H" BEAM.
 5. DETAIL OF END SPACERS SHOWS FINISHED DIMENSIONS.
 6. ALL PARTS SHALL BE OF STRUCTURAL GRADE STEEL, EXCEPT END SPACERS, WHICH MAY BE OF EITHER CAST IRON OR STEEL.
 7. ALL EXPOSED METAL PARTS SHALL BE GALVANIZED PRIOR TO ASSEMBLY, WELDING, MACHINING, AND DRILLING SHALL BE DONE BEFORE GALVANIZING. ALL DIMENSIONS ARE FINISHED DIMENSIONS AND INCLUDE GALVANIZING.
 8. TOTAL WEIGHT - 580 LBS. FOR GRATE SHOWN.

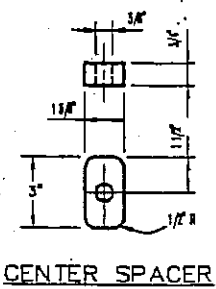
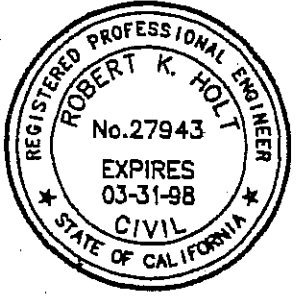

W	GRATE TYPE
25 1/2"	AS SHOWN ABOVE
24"	CALTRANS STD. D77-B

APPROVED: _____ DATE _____

APPROVED: TOWN ENGINEER
Robert K. Holt
 R.C.E. 27943

REVISION	BY	DATE



Town of
Yucca Valley

CATCH BASIN GRATE

STANDARD DRAWING NO. 477

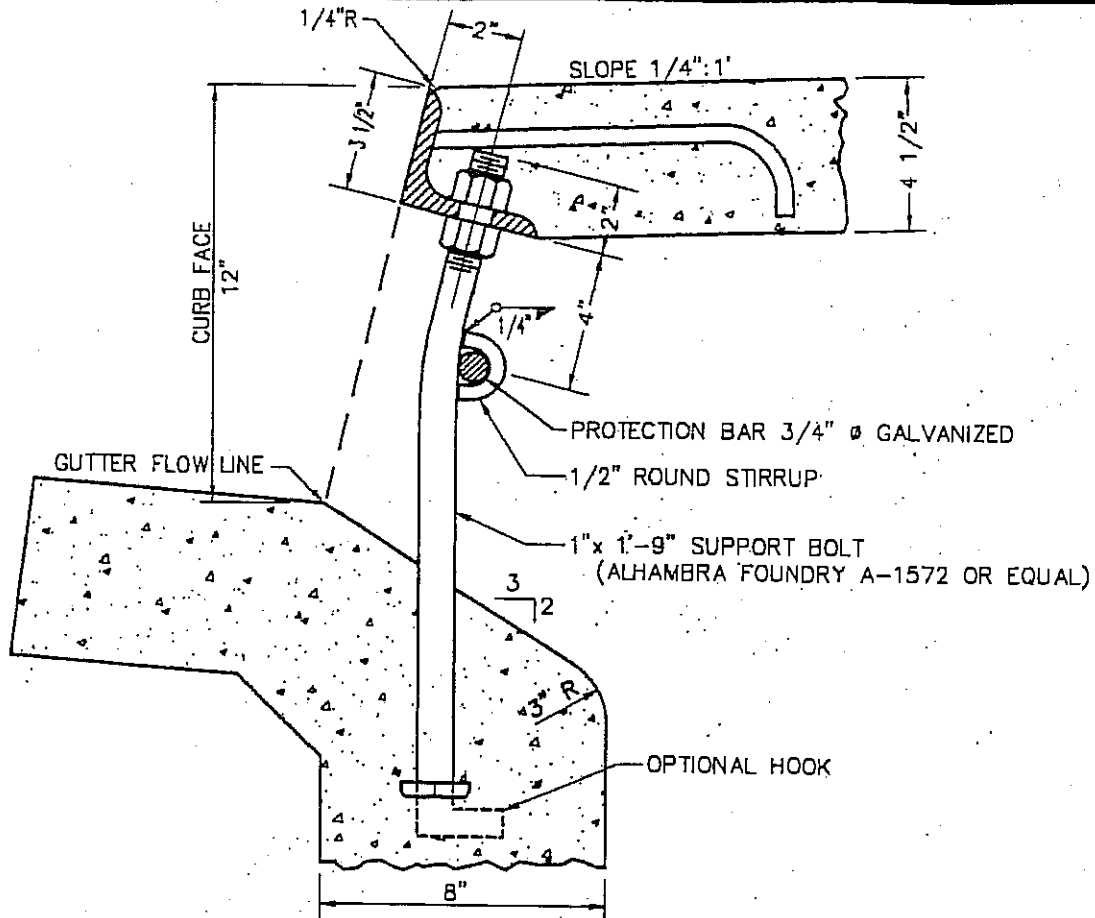

STEEL ANGLE & SUPPORT BOLT DETAIL

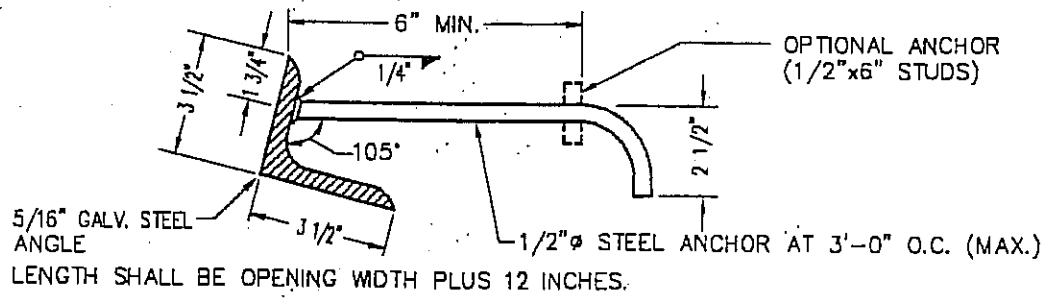

STEEL ANGLE ANCHOR

- NOTES:**
1. A PLAIN ROUND GALVANIZED STEEL PROTECTION BAR 3/4" IN DIA. SHALL BE INSTALLED AND EMBEDDED 6" AT EACH END.
 2. ALL EXPOSED METAL PARTS SHALL BE GALVANIZED. (EXCEPT FRAME AND COVER)
 3. SUPPORT BOLTS SHALL BE UNIFORMLY SPACED BUT NOT TO EXCEED 7' ON CENTER.
 4. STEEL ANGLE SHALL BE BENT TO MATCH CURB ALIGNMENT.

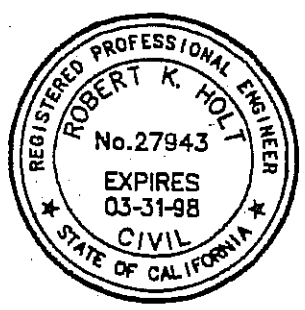

APPROVED:	DATE
APPROVED: TOWN ENGINEER <i>Robert K. Holt</i>	R.C.E. 27943
REVISION	BY DATE



Town of
Yucca Valley

CATCH BASIN
OPENING

STANDARD DRAWING NO. 480

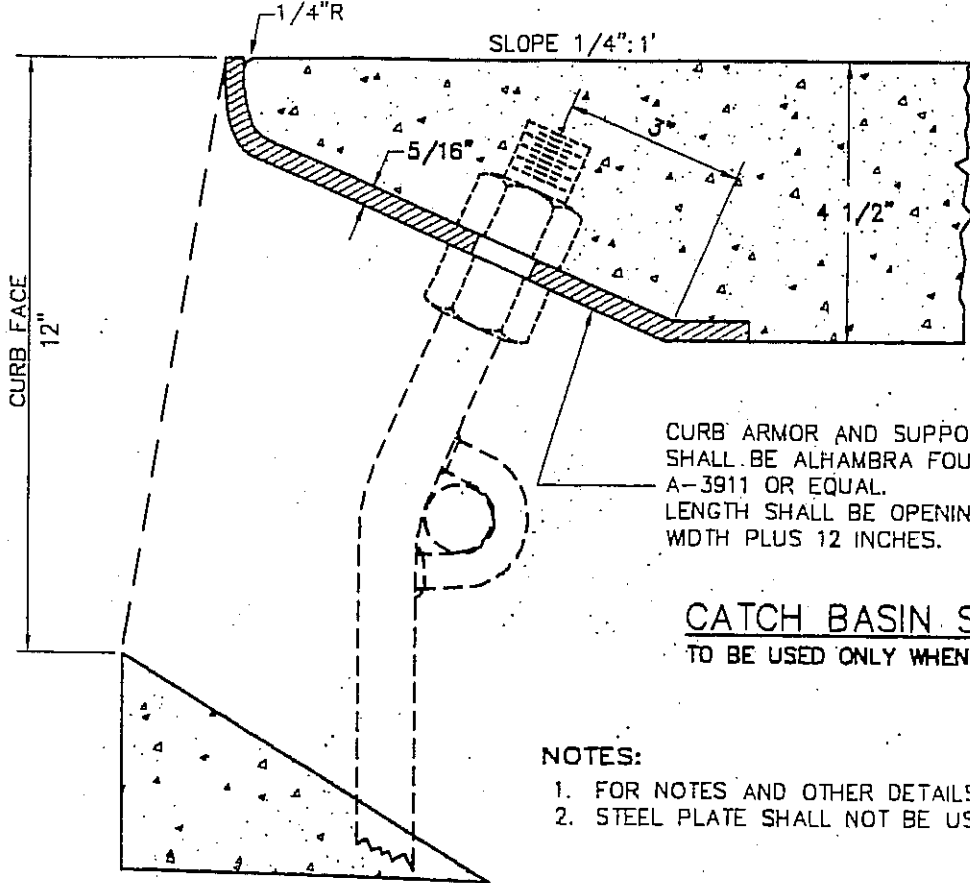

CURB ARMOR AND SUPPORT BOLTS SHALL BE ALHAMBRA FOUNDRY A-3911 OR EQUAL. LENGTH SHALL BE OPENING WIDTH PLUS 12 INCHES.

CATCH BASIN STEEL PLATE
TO BE USED ONLY WHEN SHOWN ON PLANS

NOTES:

1. FOR NOTES AND OTHER DETAILS SEE STD. NO. 480.
2. STEEL PLATE SHALL NOT BE USED ON CURVES.

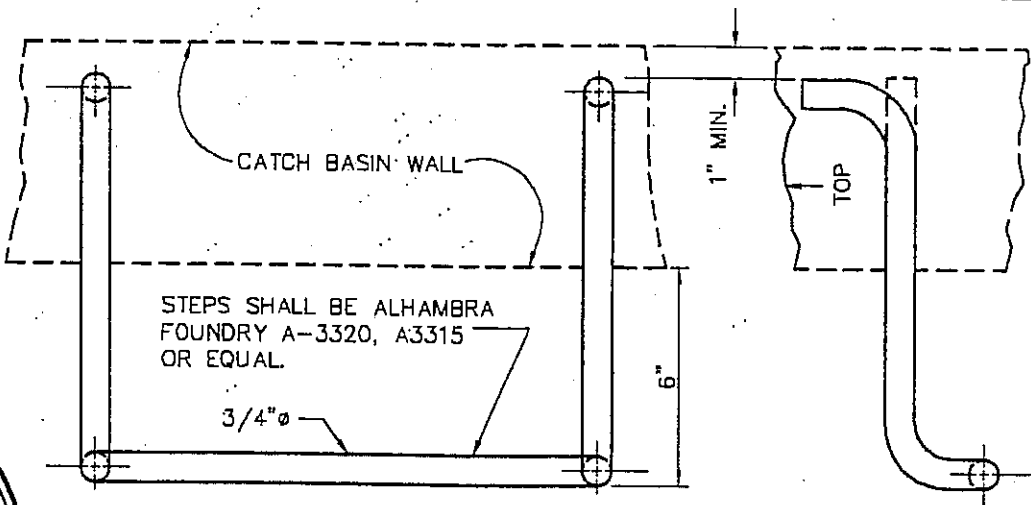

GALVANIZED STEEL STEP

NOTES:

1. STEPS - NONE REQUIRED WHERE "V" IS 3'-6" OR LESS. INSTALL ONE STEP 16"± ABOVE FLOOR WHEN "V" IS MORE THAN 3'-6" AND LESS THAN 5'-0". WHERE "V" IS MORE THAN 5'-0" STEPS SHALL BE EVENLY SPACED @ 12"± INTERVALS FROM 16"± ABOVE THE FLOOR TO WITHIN 12"± FROM THE TOP OF THE BOX. PLACE STEPS IN WALL WITHOUT PIPE OPENINGS AND UNDER MANHOLE.

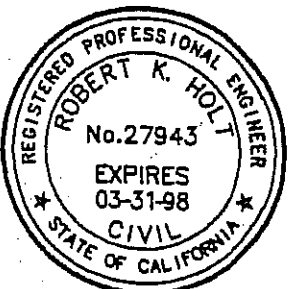

APPROVED: _____ DATE _____

APPROVED: TOWN ENGINEER
Robert K. Holt R.C.E. 27943



Town of
Yucca Valley

CATCH BASIN STEEL PLATE
GALVANIZED STEEL STEP

REVISION	BY	DATE

STANDARD DRAWING NO. 480A

"W" (INCL)	NUMBER OF SUPPORT BOLTS	NUMBER OF "X" LENGTHS
5' to 10'	1	2
10' to 15'	2	3
15' to 20'	3	4
20' to 25'	4	5
25' to 30'	5	6

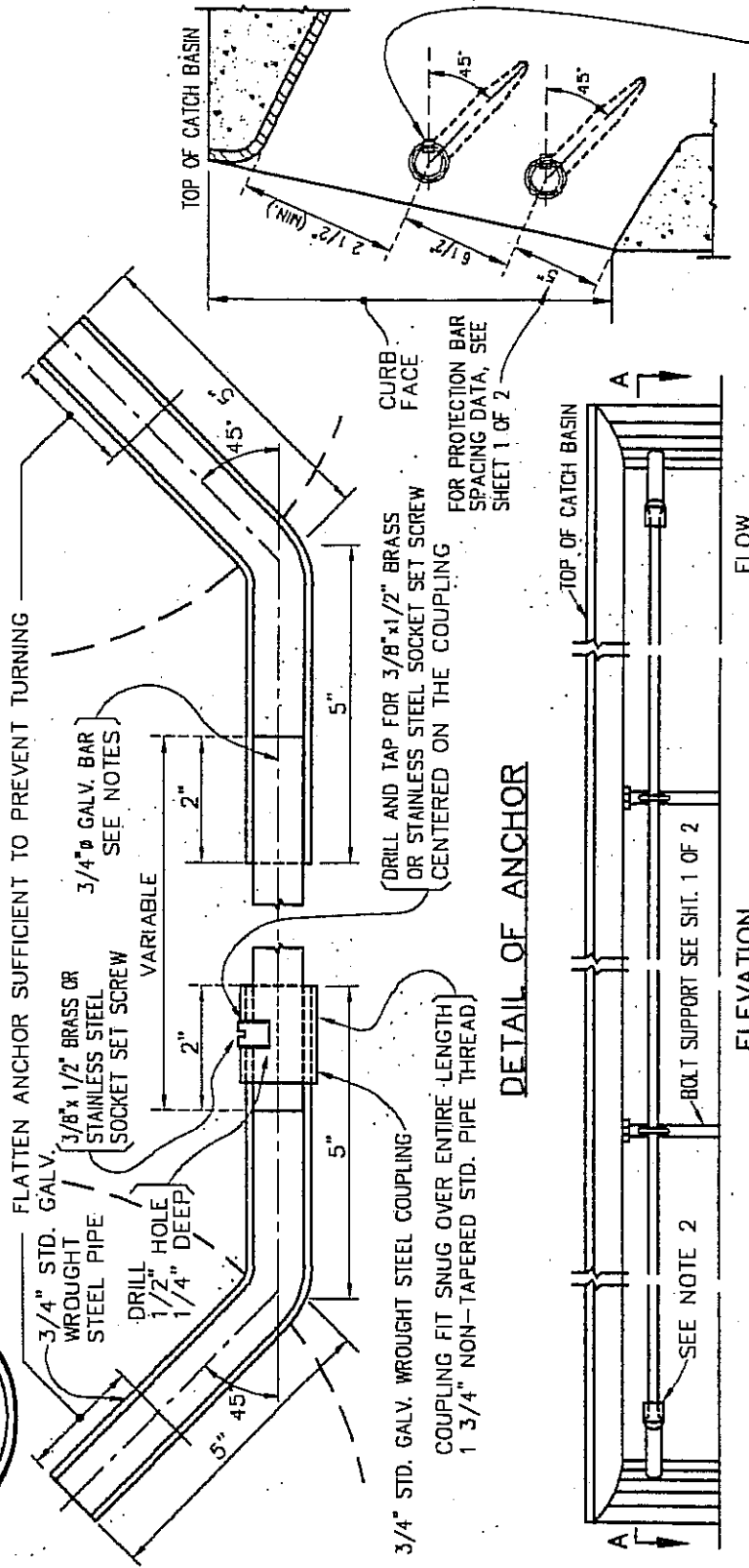

NOTE: BRASS OR STAINLESS STEEL SOCKET SET SCREW ON INSIDE OF CATCH BASIN

SECTION SHOWING LOCATION OF ANCHOR AT WALL OF CATCH BASIN

DETAIL OF ANCHOR

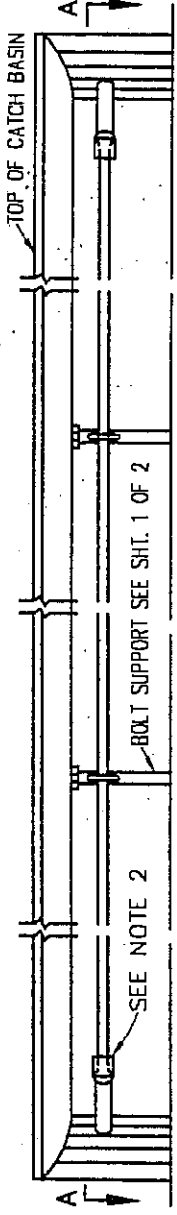

ELEVATION

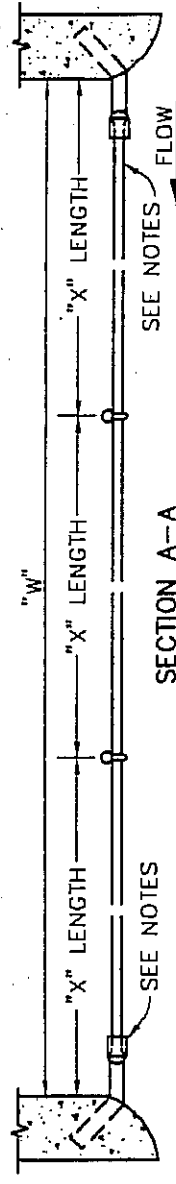

SECTION A-A

NOTES:

1. ALL BARS SHALL BE 3/4" GALV. HOT-ROLLED STEEL PER A.S.T.M. DESIGNATION A-36. BAR LENGTHS SHALL NOT EXCEED 21' AND SHALL BE CUT TO FIT IN THE FIELD. WHEN "W" IS OVER 21', PROTECTION BAR SHALL CONSIST OF TWO OR MORE SECTIONS DEPENDING UPON LENGTH OF BASIN. LOCATION OF SPECIAL SUPPORT BARS AND ADDITIONAL SOCKET SET SCREW TO BE DETERMINED BY THE ENGINEER IN THE FIELD.
2. INSTALL COUPLING AT DOWNSTREAM END OF CATCH BASIN OPENING.



APPROVED: _____ DATE _____

APPROVED: TOWN ENGINEER
Robert K. Holt
R.C.E. 27943

REVISION	BY	DATE



Town of
Yucca Valley

REMOVABLE PROTECTION BAR FOR CATCH BASINS

STANDARD DRAWING NO. 481

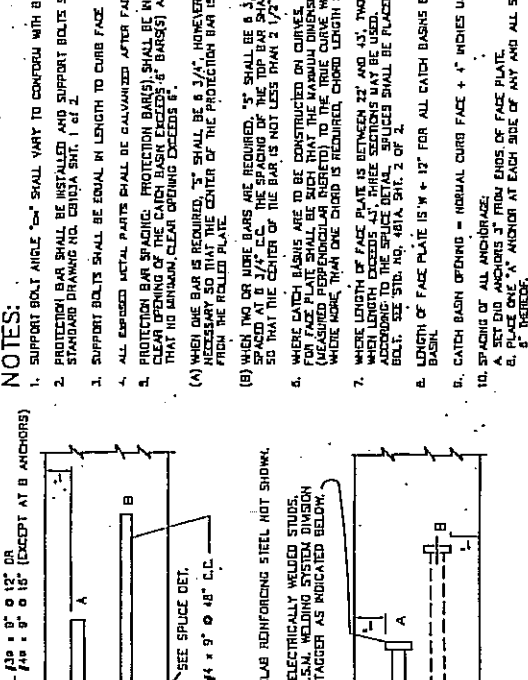

DETAIL OF CATCH BASIN OPENING

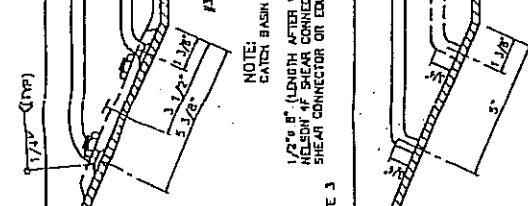

DETAIL OF CATCH BASIN OPENING

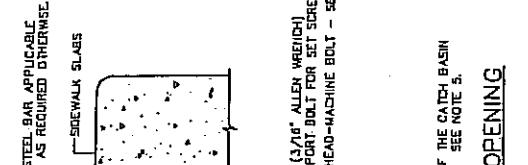

DETAIL OF CATCH BASIN OPENING

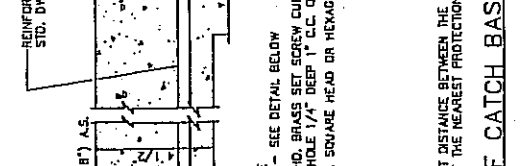

DETAIL OF CATCH BASIN OPENING

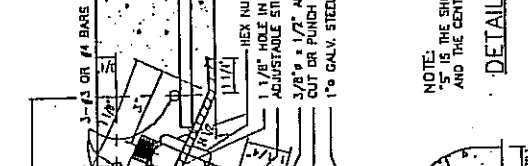

DETAIL OF CATCH BASIN OPENING



DETAIL OF CATCH BASIN OPENING

DETAIL OF CATCH BASIN OPENING

- NOTES:**
- SUPPORT BOLT HOLE "S" SHALL VARY TO CONFORM WITH BATTER OF ADJOINING CURB.
 - PROTECTION BAR SHALL BE INSTALLED AND SUPPORT BOLTS SPACED ACCORDING TO STANDARD DRAWING NO. CRCHA SH1, 1 of 2.
 - SUPPORT BOLTS SHALL BE EQUAL IN LENGTH TO CURB FACE + 1/2" FOR ALL CURB BATTERS.
 - ALL EXPOSED METAL PARTS SHALL BE GALVANIZED AFTER FABRICATION.
 - PROTECTION BAR SPACING, PROTECTION BARS SHALL BE INSTALLED WITH THE MINIMUM CLEAR OPENING OF THE CATCH BASIN (SEE BARS) AND SHALL BE PLACED SUCH THAT NO MINIMUM CLEAR OPENING EXCEEDS 6".
 - WHEN ONE BAR IS REQUIRED, "S" SHALL BE 3/4", HOWEVER, THIS SHALL BE REDUCED 1/2" WHEN THE CENTER OF THE PROTECTION BAR IS NOT LESS THAN 3 1/2" FROM THE ROLLED PLATE.
 - WHEN TWO OR MORE BARS ARE REQUIRED, "S" SHALL BE 3/4" WITH REMAINING BARS SPACED AT 1/2" C.C. THE SPACING OF THE TOP BAR SHALL BE REDUCED IF ACCESSARY SO THAT THE CENTER OF THE BAR IS NOT LESS THAN 1/2" FROM THE ROLLED PLATE.
 - WHERE CATCH BASINS ARE TO BE CONSTRUCTED ON CURVES, THE MAXIMUM CHORD LENGTH FOR FACE PLATE SHALL BE SUCH THAT THE MAXIMUM DIMENSION FROM END CHORD TO TRUE CURVE WILL NOT EXCEED ONE FOOT. WHERE NECESSARY, CHORD LENGTH SHALL BE EQUAL.
 - WHEN LENGTH OF FACE PLATE IS BETWEEN 22" AND 43", TWO SECTIONS MAY BE USED. WHEN LENGTH EXCEEDS 43", THREE SECTIONS MAY BE USED. SECTIONS SHALL BE SPACED AS SHOWN IN FIG. 1, 2, 3, 4, 5, 6, 7, 8, 9, 10, 11, 12, 13, 14, 15, 16, 17, 18, 19, 20, 21, 22, 23, 24, 25, 26, 27, 28, 29, 30, 31, 32, 33, 34, 35, 36, 37, 38, 39, 40, 41, 42, 43, 44, 45, 46, 47, 48, 49, 50, 51, 52, 53, 54, 55, 56, 57, 58, 59, 60, 61, 62, 63, 64, 65, 66, 67, 68, 69, 70, 71, 72, 73, 74, 75, 76, 77, 78, 79, 80, 81, 82, 83, 84, 85, 86, 87, 88, 89, 90, 91, 92, 93, 94, 95, 96, 97, 98, 99, 100.
 - CATCH BASIN OPENING = NORMAL CURB FACE + 4" UNLESS OTHERWISE SPECIFIED.
 - SPACING OF ALL ANCHORAGE:
 - ALL ANCHORS SHALL BE PLACED AT EACH END OF FACE PLATE.
 - ALL ANCHORS SHALL BE PLACED AT EACH END OF FACE PLATE AND ALL SPICE JOINTS AND WITHIN 5" THEREOF.

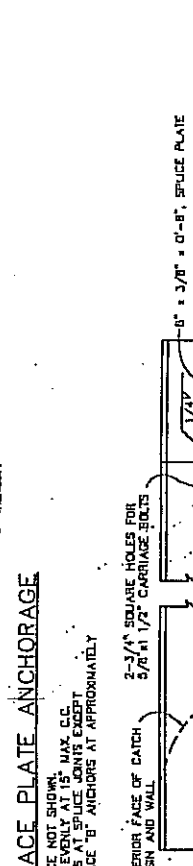

ALTERNATE METHODS FOR FACE PLATE ANCHORAGE

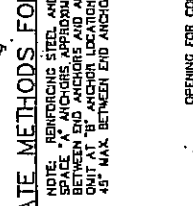

ALTERNATE METHODS FOR FACE PLATE ANCHORAGE



ALTERNATE METHODS FOR FACE PLATE ANCHORAGE



ALTERNATE METHODS FOR FACE PLATE ANCHORAGE

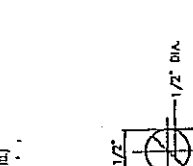

ALTERNATE METHODS FOR FACE PLATE ANCHORAGE



ALTERNATE METHODS FOR FACE PLATE ANCHORAGE

ALTERNATE METHODS FOR FACE PLATE ANCHORAGE

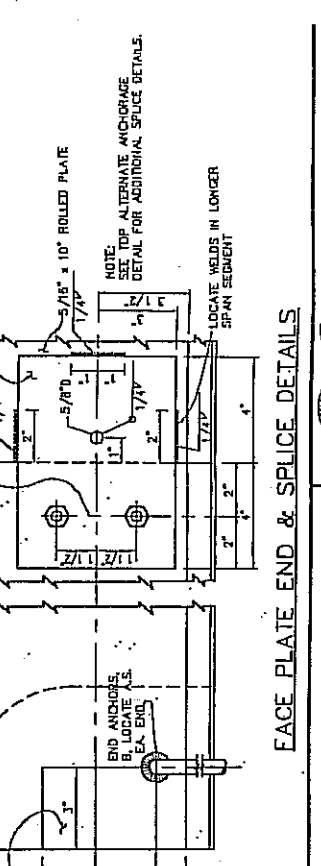

FACE PLATE END & SPICE DETAILS

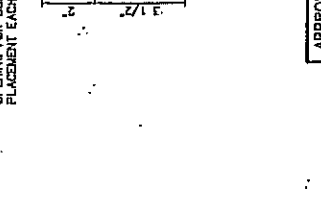

FACE PLATE END & SPICE DETAILS



FACE PLATE END & SPICE DETAILS

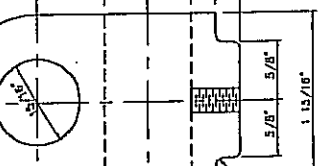

FACE PLATE END & SPICE DETAILS

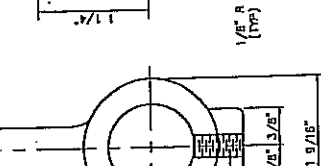

FACE PLATE END & SPICE DETAILS

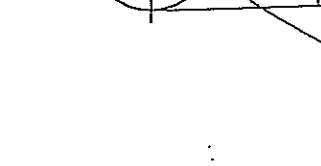

FACE PLATE END & SPICE DETAILS

FACE PLATE END & SPICE DETAILS

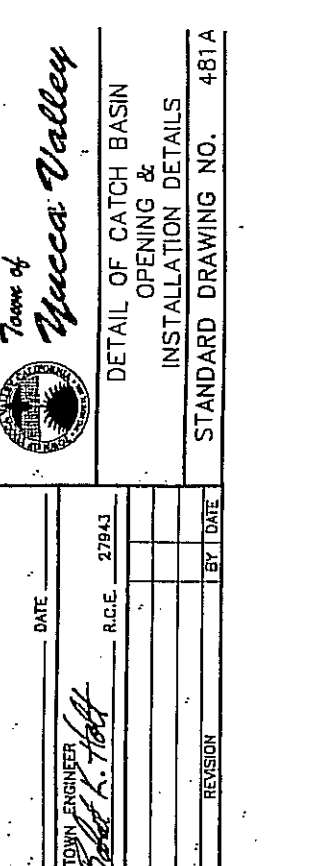

FACE PLATE END & SPICE DETAILS

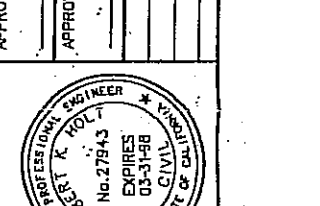

FACE PLATE END & SPICE DETAILS

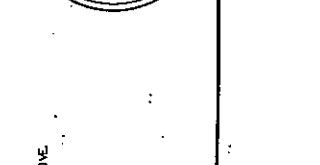

FACE PLATE END & SPICE DETAILS

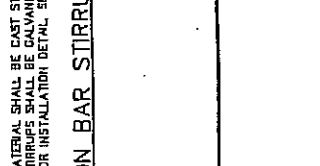

FACE PLATE END & SPICE DETAILS

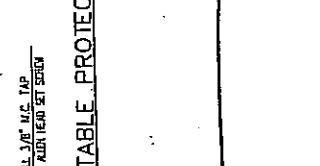

FACE PLATE END & SPICE DETAILS

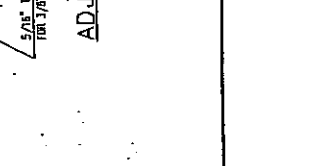

FACE PLATE END & SPICE DETAILS

FACE PLATE END & SPICE DETAILS

APPROVED: _____ DATE _____

APPROVED: TOWN ENGINEER R.C.E. 27943

REVISION _____ BY _____ DATE _____

Town of **Yucca Valley**

DETAIL OF CATCH BASIN OPENING & INSTALLATION DETAILS

STANDARD DRAWING NO. 481A

REGISTERED PROFESSIONAL ENGINEER

ROBERT K. HOLT

No. 27943

EXPIRES 05-31-98

CIVIL ENGINEER

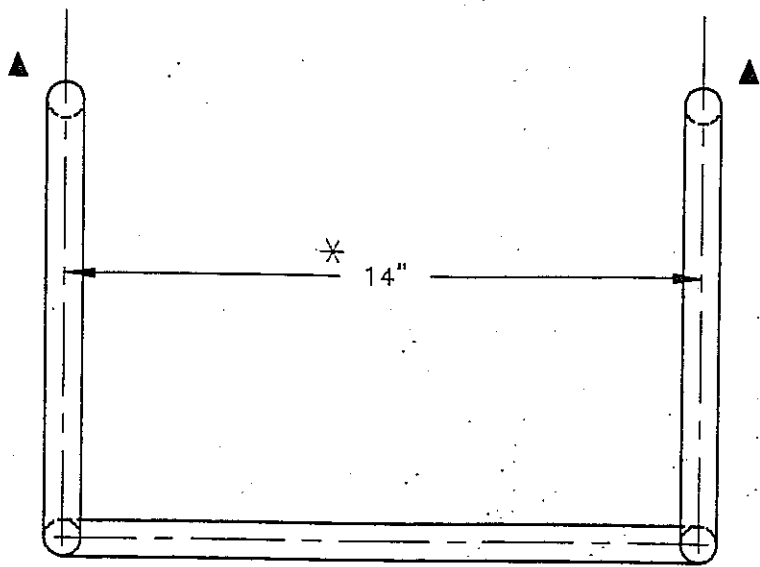

PLAN VIEW

NOTE:
 ▲ = WHEN STEEL FORMS ARE USED, ELIMINATE HOOK AND USE UPSET END.

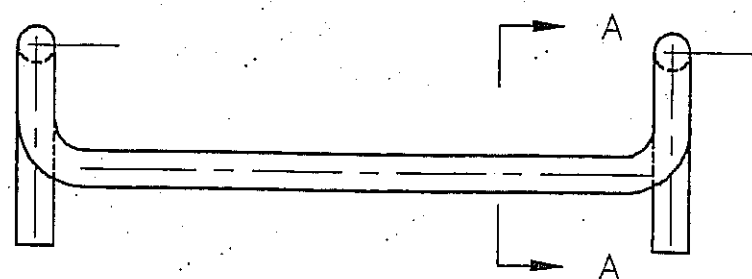

FRONT ELEVATION

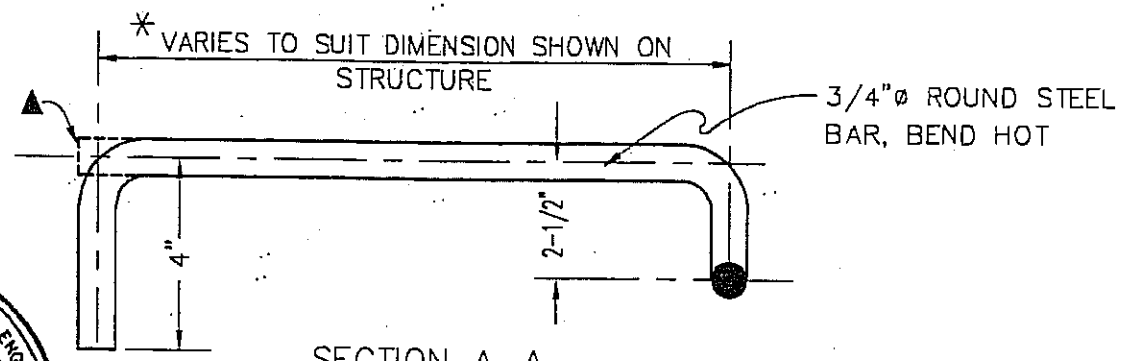

SECTION A-A
GALVANIZE AFTER BENDING

NOTE:
 THIS DETAIL SHALL BE USED WHEREVER STEPS ARE REQUIRED.

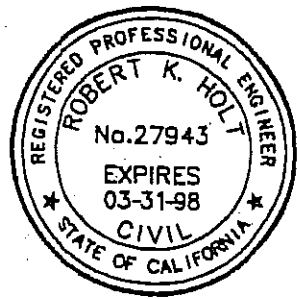

APPROVED:	DATE _____
APPROVED: TOWN ENGINEER <i>Robert K. Holt</i>	R.C.E. 27943
REVISION	BY DATE



Town of
Yucca Valley

STANDARD
 DROP STEP

STANDARD DRAWING NO. 482

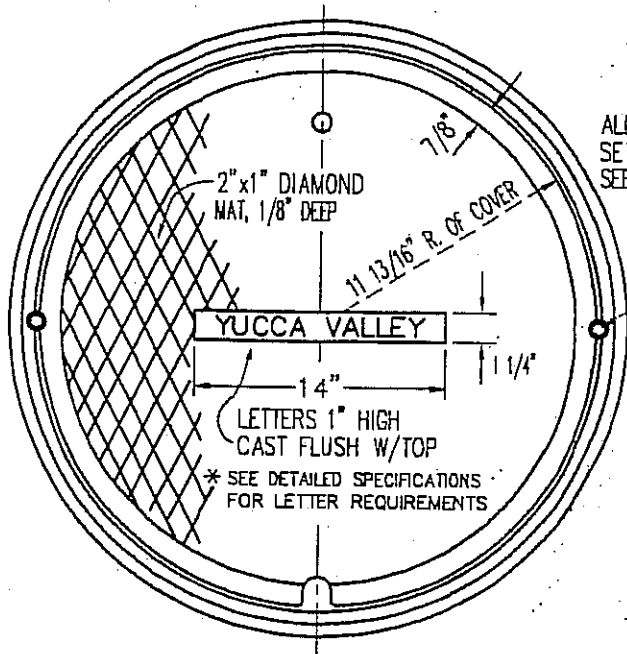

TOP OF MANHOLE FRAME & COVER
TOTAL WT. = 130 lbs.

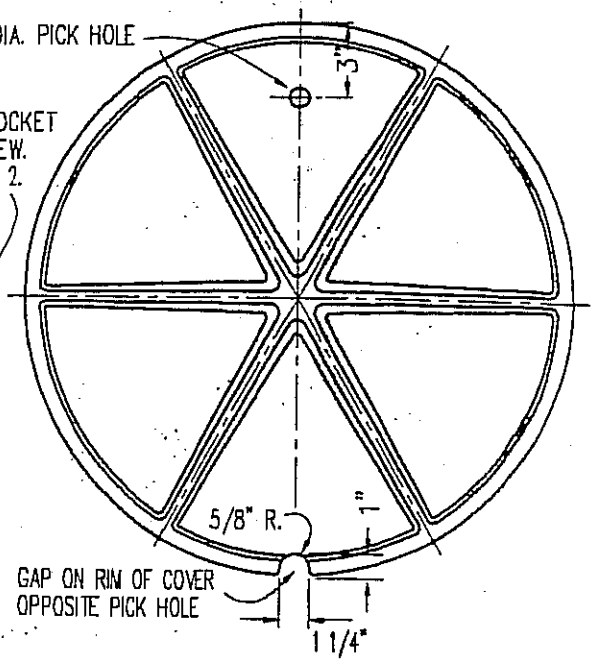

BOTTOM OF MANHOLE COVER

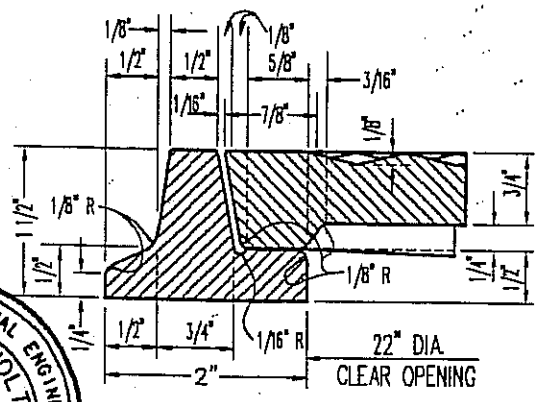
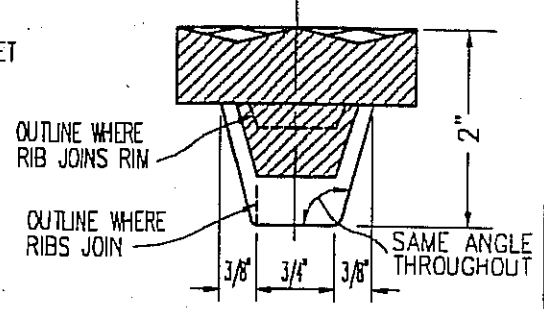
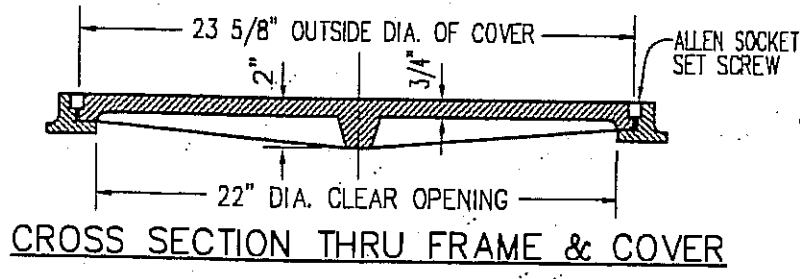

CROSS SECTION THRU RIB

NOTES:

1. FRAME AND COVER SHALL BE GRAY CAST IRON CONFORMING TO THE LATEST A.S.T.M. STANDARD A48, CLASS 30 OR BETTER. GALVANIZE PER A.S.T.M. A385.
2. INSTALL TWO 3/4" x 3/4" ALLEN SOCKET SET SCREWS, 90° TO PICK HOLE, IN HOLES DRILLED AND TAPPED 1" IN DEPTH. GALVANIZE PER A.S.T.M. 153.
3. FRAME AND COVER SHALL BE TESTED FOR ACCURACY OF FIT AND SHALL BE MARKED IN SETS BEFORE DELIVERY. RETAP FRAME AS REQUIRED TO SUIT SET SCREWS.

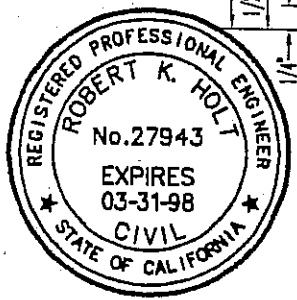

APPROVED: _____ DATE _____

APPROVED: TOWN ENGINEER
Robert K. Holt R.C.E. 27943



Town of
Yucca Valley

MANHOLE FRAME &
COVER FOR CATCH BASINS

STANDARD DRAWING NO. 483

REVISION	BY	DATE

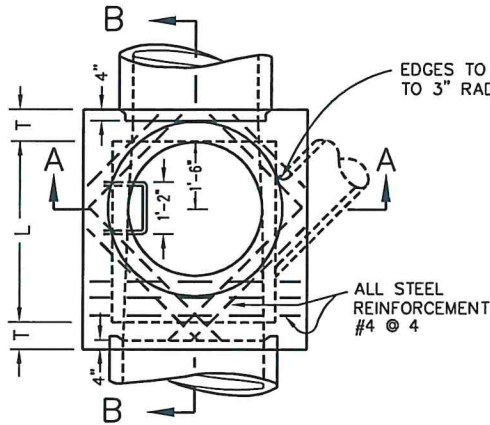

PLAN
(SHAFT NOT SHOWN)

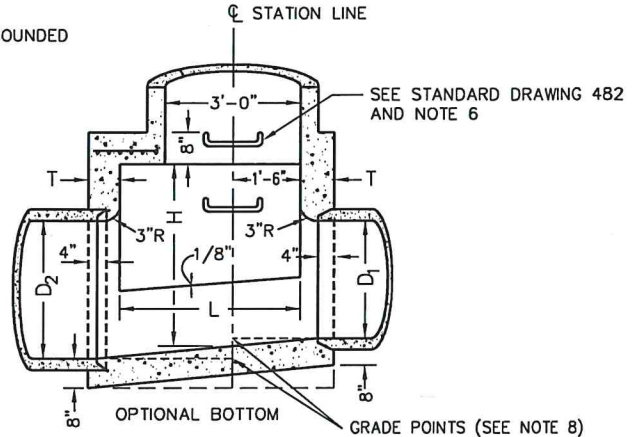

SECTION B-B

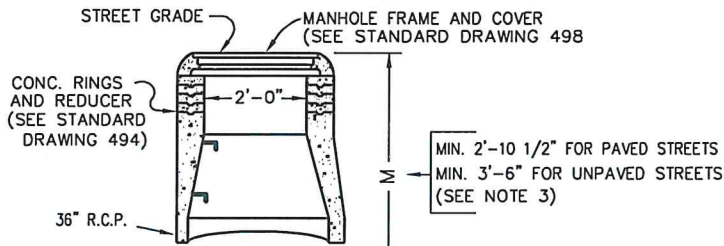

SECTION A-A

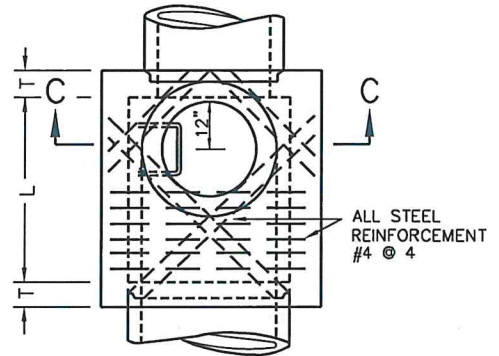

DETAIL N
PLAN
(SHAFT NOT SHOWN, SEE NOTE 3)

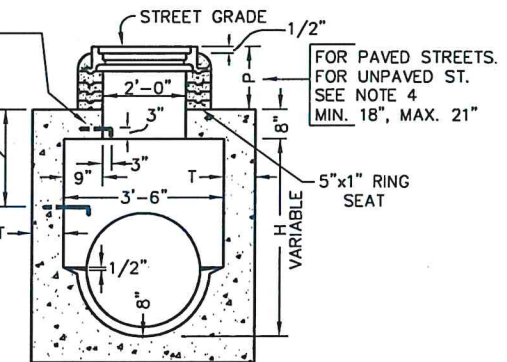
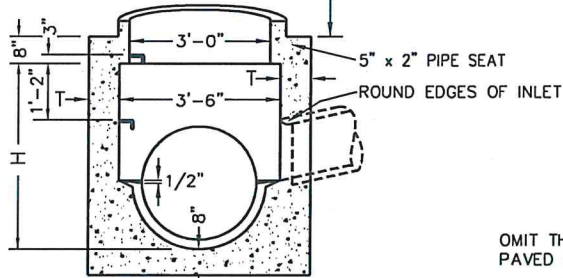

SECTION C-C

NOTE: FOR PIPE DIAMETERS 33" AND SMALLER



APPROVED: DIRECTOR OF PUBLIC WORKS

Alex Christos DATE *4/21/25*

APPROVED: TOWN ENGINEER

Noel Owsley R.C.E. 39827

ADD PIPE DIAMETER NOTE -N- 8/30/24

REVISION BY DATE



Town of
Yucca Valley

STORM DRAIN
MANHOLE NO. 1
SHEET 1 OF 2

STANDARD DRAWING NO. 490

1. HEIGHT H SHALL BE NOT LESS THAN 4'-0" BUT MAY BE INCREASED AT OPTION OF CONTRACTOR PROVIDED THAT THE VALUE OF M SHALL NOT BE LESS THAN THE MINIMUM SPECIFIED AND THAT THE REDUCER SHALL BE USED. FOR H (IN SEC. C-C) SEE NOTE 4.
2. LENGTH L SHALL BE 4' UNLESS OTHERWISE SHOWN ON IMPROVEMENT PLAN. L MAY BE INCREASED OR LOCATION OF MANHOLE SHIFTED TO MEET PIPE ENDS AT THE OPTION OF THE CONTRACTOR, EXCEPT THAT ANY CHANGE IN LOCATION OF MANHOLE MUST BE APPROVED BY THE ENGINEER.
3. SHAFT SHALL BE CONSTRUCTED AS PER SEC. C-C AND DETAIL N WHEN DEPTH M FROM STREET GRADE TO TOP OF BOX IS LESS THAN 2'-10 1/2" FOR PAVED STREETS OR 3'-6" FOR UNPAVED STREETS.
4. DEPTH P MAY BE REDUCED TO AN ABSOLUTE LIMIT OF 6 INCHES WHEN LARGER VALUES OF P WOULD REDUCE H (IN SEC. C-C) TO BE 3'-6" OR LESS.
5. T SHALL BE 8" FOR VALUES OF H UP TO AND INCLUDING 8 FEET. T SHALL BE 10" FOR VALUES OF H OVER 8 FEET.
6. STEPS SHALL BE 3/4" ROUND, GALVANIZED STEEL AND ANCHORED NOT LESS THAN 4" IN THE WALLS OF STRUCTURES. UNLESS OTHERWISE SHOWN, STEPS SHALL BE SPACED 16" ON CENTER. THE LOWEST STEP SHALL BE NOT MORE THAN 2 FT. ABOVE THE INVERT.
7. REINFORCING STEEL SHALL BE NO. 4 AND 1-1/2" CLEAR FROM INSIDE FACE OF CONCRETE.
8. STATIONS REFER TO PLAN AND PROFILE SHEETS. ELEVATIONS AT ϕ AND PROLONGED INVERT GRADE LINE. SEE NOTE 2 FOR SHIFTING LOCATION.
9. RINGS, REDUCER, AND PIPE FOR ACCESS SHAFT SHALL BE SEATED IN CEMENT MORTAR AND NEATLY POINTED OR WIPED INSIDE SHAFT.
10. FLOOR OF MANHOLE SHALL BE STEEL-TROWELED.
11. CONCRETE SHALL BE CLASS "A".



APPROVED:

DATE _____

APPROVED: TOWN ENGINEER

Robert K. Holt

R.C.E. 27943



Town of
Yucca Valley

STORM DRAIN
MANHOLE NO. 1

SHEET 2 OF 2

REVISION

BY DATE

STANDARD DRAWING NO. 490A

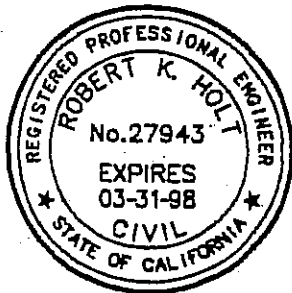

APPROVED:

APPROVED: TOWN ENGINEER

Robert K. Holt

DATE

R.C.E. 27943

REVISION

BY DATE



Town of
Yucca Valley

STORM DRAIN
MANHOLE No. 2

STANDARD DRAWING NO. 491

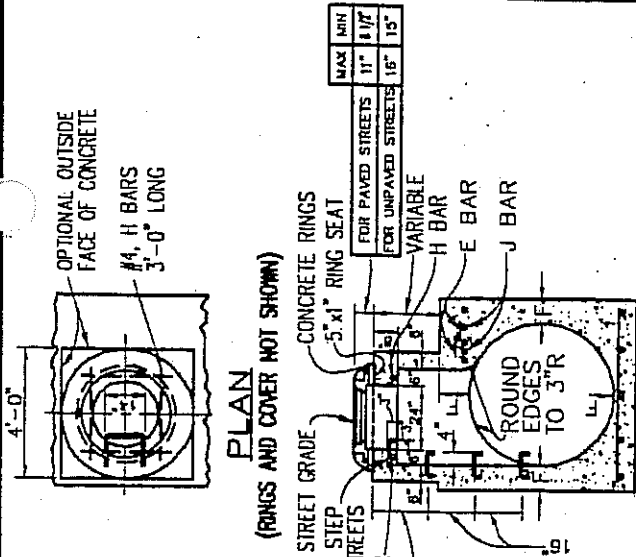
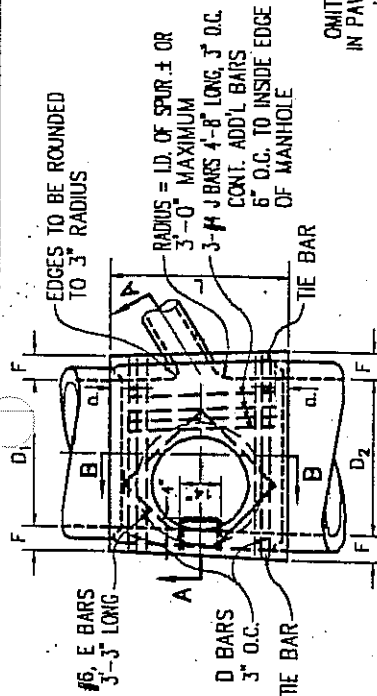

DETAIL M (SEE NOTE 3)

NOTES:

- TABLE OF VALUES FOR "F" ARE ON THIS PLAN.
- CENTER OF MANHOLE SHAFT SHALL BE LOCATED OVER CENTERLINE OF STORM DRAIN WHEN DIAMETER D₁ IS 48" OR LESS, IN WHICH CASE PLACE E BARS SYMMETRICALLY AROUND SHAFT AT 45° WITH CENTERLINE AND OMIT J BARS.
- DETAIL M: WHEN DEPTH OF MANHOLE FROM STREET GRADE TO TOP OF BOX IS LESS THAN 2'-10 1/2" FOR PAVED STREETS OR 3'-6" FOR UNPAVED STREETS, CONSTRUCT MONOLITHIC SHAFT PER DETAIL M. SHAFT FOR ANY DEPTH OF MANHOLE MAY BE CONSTRUCTED PER DETAIL M, WHEN DIAMETER D₁ IS 48" OR LESS, CENTER OF SHAFT MAY BE LOCATED PER NOTE 2.
- THICKNESS OF DECK SHALL VARY WHEN NECESSARY TO PROVIDE LEVEL PIPE SEAT BUT SHALL NOT BE LESS THAN TABULAR VALUES FOR F SHOWN ON THIS PLAN.
- REINFORCING STEEL TO BE ROUND, DEFORMED BARS, 1-1/2" CLEAR FROM INSIDE FACE OF CONCRETE UNLESS OTHERWISE SHOWN.
- STEPS SHALL 3/4" ROUND, GALVANIZED STEEL AND ANCHORED NOT LESS THAN 2" IN THE WALL OF STRUCTURE UNLESS OTHERWISE SHOWN, THE SPACING SHALL BE 18". THE LOWEST STEP SHALL NOT BE MORE THAN 2'-0" ABOVE THE INVERT. SEE STD. DWG. 482.
- RINGS, REDUCER AND PIPE FOR ACCESS SHAFT SHALL BE SEATED IN HORIZONTAL AND NEATLY POINTED OR WIPED INSIDE THE SHAFT.
- ELEVATIONS OF MANHOLES SHOWN ON PLAN APPLY AT CENTER OF SHAFT.
- FLOOR OF MANHOLE SHALL BE STEEL-TROWELED TO SPRING LINE.
- BODY OF MANHOLE SHALL BE Poured IN ONE CONTINUOUS OPERATION EXCEPT THAT A CONSTRUCTION JOINT WITH A LONGITUDINAL KEYWAY MAY BE PLACED AT THE SPRING LINE.
- LENGTH L AND EMBEDMENT P SHALL HAVE THE FOLLOWING VALUES UNLESS OTHERWISE SHOWN ON PLAN:
FOR D₁ = 66" OR LESS, L = 5'-9", P = 5'-0"
D₁ OVER 66", L = 6'-0", P = 6'-0"
- L MAY BE INCREASED OR LOCATION OF MANHOLE SHIFTED TO MEET PIPE ENDS WHEN L IS GREATER THAN THAT SHOWN ABOVE IS SPECIFIED, D BARS SHALL BE CONTINUED 8" O.C.
- D BARS SHALL BE #4 FOR D₁ = 36" OR LESS, #5 FOR D₁ = 42" TO 64" INCLUSIVE AND #6 FOR D₁ = 60" OR OVER. THE BARS SHALL BE #4 BARS.
- STRUCTURAL CONCRETE SHALL BE CLASS "A".
- CENTERLINE OF INLET PIPE TO INTERSECT INSIDE FACE OF CONE AT SPRING LINE UNLESS OTHERWISE SHOWN.
- WHEN PRESSURE MANHOLE NO. 2 IS SPECIFIED ON PLANS, SEE STD. DWG. 495 AND NOTE 3.

#D ₂ D ₁	F	#D ₂ D ₁	F
36"	5 1/2"	78"	11 3/4"
39"	7"	84"	12 1/2"
42"	7 1/2"	90"	13 1/4"
45"	7 3/4"	96"	14"
48"	8"	102"	15 1/2"
51"	8 1/2"	108"	16"
54"	9"	114"	16 1/2"
57"	9 1/4"	120"	17"
60"	9 1/2"	126"	17 1/2"
63"	10"	132"	18 1/2"
66"	10 1/4"	138"	19 1/2"
69"	10 3/4"	144"	20"
72"	11"		

* USE D₂ OR D₁, WHICHEVER IS GREATER

SECTION A-A

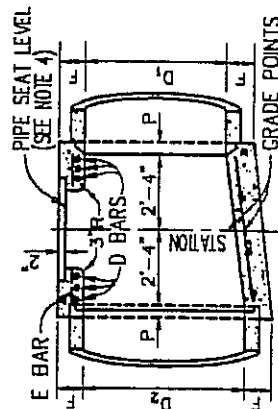

SIZE AND SPACING OF STEEL AS SHOWN ON IMPROVEMENT PLAN, EXCEPT THAT 5 BARS ON EACH SIDE OF SHAFT SHALL BE NOT SMALLER THAN #5 @ 4" O.C. OR EQUIVALENT.

#5 BARS 5' LONG @ 4" C.C.

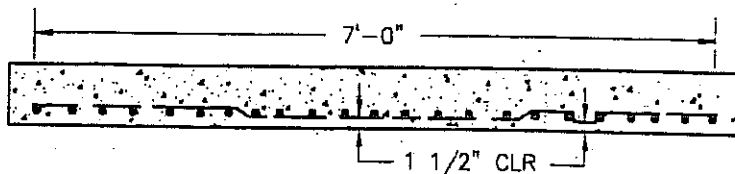

SECTION A-A

5 BARS 7' LONG 4" O.C. OF SIZE SHOWN FOR TRANSVERSE STEEL ON IMPROVEMENT PLAN EXCEPT NOT LESS THAN #5. WARP THESE BARS UNDER BARS THAT HAVE BEEN CUT FOR SHAFT OPENING

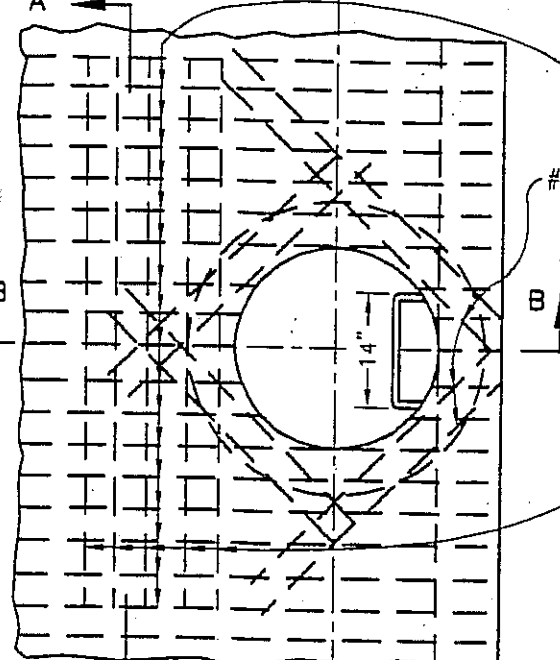

PLAN
(SHAFT NOT SHOWN)

STREET GRADE
MANHOLE FRAME AND COVER (SEE STD. DWG. 498)

CONCRETE RINGS AND REDUCER (SEE STD. DWG. 494)

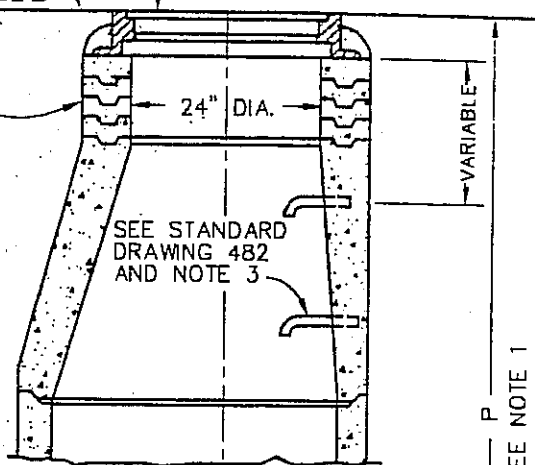

NOTE:

- 1- DEPTH P: WHEN DEPTH P FROM STREET GRADE TO TOP OF PIPE SEAT IS LESS THAN 2'-10 1/2" IN PAVED STREETS OR 3'-6" IN UNPAVED STREETS, CONSTRUCT 2 FT. DIAMETER SHAFT USING CONCRETE RINGS AS PER STANDARD PLAN FOR CONCRETE RINGS, OTHERWISE, CONSTRUCT 3 FT. SHAFT AS SHOWN ON THIS PLAN.
- 2- STATIONS SHOWN ON IMPROVEMENT PLAN REFER TO CENTERLINE OF SHAFT.
- 3- STEPS SHALL BE 3/4" ROUND GALVANIZED STEEL ANCHORED NOT LESS THAN 4" IN WALLS OF STRUCTURE AND UNLESS OTHERWISE SHOWN, SHALL BE SPACED 16" ON CENTER. THE LOWEST STEP SHALL NOT BE MORE THAN 2 FEET ABOVE THE FLOOR.

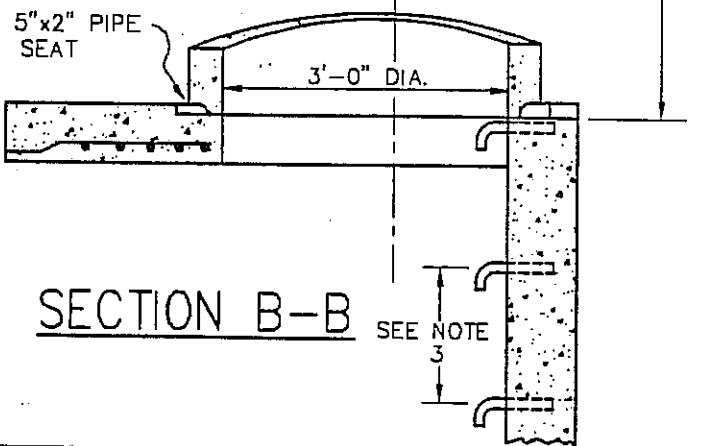

SECTION B-B

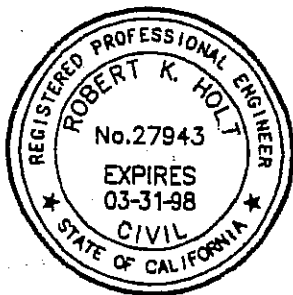

APPROVED: _____ DATE _____

APPROVED: TOWN ENGINEER
Robert K. Holt R.C.E. 27943



Town of
Yucca Valley

STORM DRAIN
MANHOLE NO. 3

STANDARD DRAWING NO. 492

REVISION	BY	DATE

3/4" GALV. STEEL STEPS 18" O.C. (SEE STD. DWG. 482, 483, AND NOTE 6)

5'-2" PIPE SEAT

3/8" R.C.P.

CONCRETE RINGS FOR PAVED STREETS 11" B 1/2" FOR UNPAVED STREETS 1/2" L 5"

MAX. MIN.

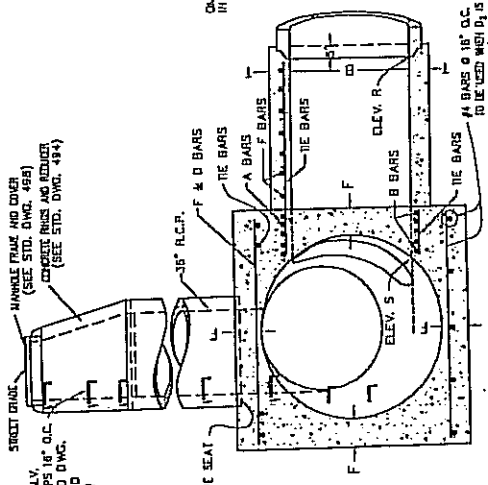

SECTION N-N-P-Q
PROJECTED P-P-Q

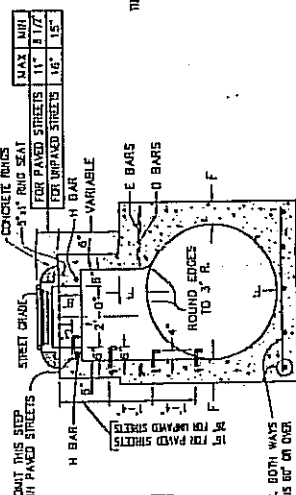

DETAIL M
(SEE NOTE 3)

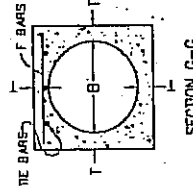

SECTION G-G

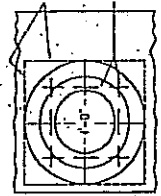

PLAN
(PIES AND COVER NOT SHOWN)

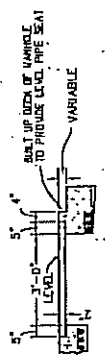

SEAT FOR SHAFT
WHEN TOP IS NOT LEVEL

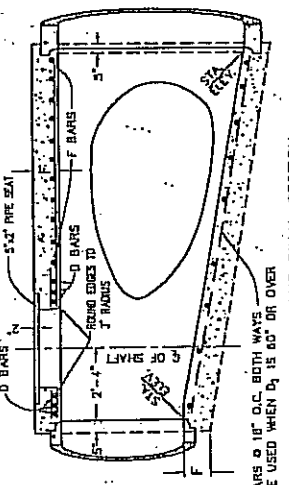

LONGITUDINAL SECTION

* BARS 18" O.C. BOTH WAYS TO BE USED WHEN D₁ IS 60" OR OVER

TABLE OF BAR SIZES			
D ₁ , D ₂ OR B	A & B BARS	D & F BARS	
12" - 36"	NO. 5 @ 3"	NO. 4 @ 6"	
42" - 64"	NO. 5 @ 3"	NO. 5 @ 6"	
90" - 144"	NO. 7 @ 3"	NO. 5 @ 6"	

* USE D₂ OR D₁, WHICHEVER IS GREATER, OR B.

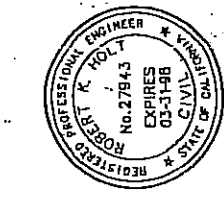

APPROVED: _____ DATE _____

APPROVED: TOWN ENGINEER
Robert K. Holt R.C.E. 27943

REVISION	BY	DATE

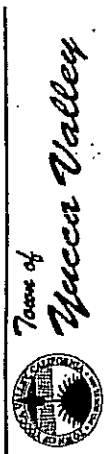

STORM DRAIN
MANHOLE NO. 4

STANDARD DRAWING NO. 493

NOTES

- 1- VALUES FOR A, B, C, D₁, D₂, ELEV. R AND ELEV. S ARE SHOWN ON THE IMPROVEMENT PLANS. TABLE OF VALUES FOR F AND T HEREON.
- 2- LATERALS: IF LATERALS ENTER ON BOTH SIDES OF MANHOLE, ACCESS SHAFT SHALL BE LOCATED ON SIDE RECEIVING THE SMALLER LATERAL.
- 3- CENTER OF MANHOLE SHAFT SHALL BE LOCATED OVER CENTERLINE OF MAIN STORM DRAIN WHEN D₁ IS 48" OR LESS, IN WHICH CASE PLACE 8 E BARS SYMMETRICALLY AROUND SHAFT AT 45' WITH CENTERLINE.
- 4- LENGTH L MAY BE INCREASED AT OPTION OF CONTRACTOR TO MEET PIPE ENDS, BUT ANY CHANGE IN LOCATION OF SPUR MUST BE APPROVED BY THE ENGINEER.
- 5- DETAIL N: WHEN DEPTH OF MANHOLE FROM STREET GRADE TO TOP OF BOX IS LESS THAN 2'-10 1/2" FOR PAVED STREETS OR 3'-6" FOR UNPAVED STREETS, CONSTRUCT MONOLITHIC SHAFT PER DETAIL N. THE CONTRACTOR SHALL HAVE THE OPTION OF CONSTRUCTING SHAFT AS PER DETAIL N FOR ANY DEPTH OF MANHOLE WHEN DIAMETER D₁ IS 48" OR LESS, CENTER OF SHAFT SHALL BE LOCATED PER NOTE 3.
- 6- REINFORCING STEEL SHALL BE ROUND, DEFORMED, STRAIGHT BARS, 1 1/2" CLEAR FROM INSIDE FACE UNLESS OTHERWISE SHOWN. THE BARS SHALL BE NO. 4 AND SPACED 18" ON CENTERS OR CLOSER.
- 7- CONCRETE SHALL BE CLASS "A".
- 8- STEPS SHALL BE 3/4" GALVANIZED STEEL AND ANCHORED NOT LESS THAN 4" IN WALLS OF STRUCTURE. UNLESS OTHERWISE SHOWN THE SPACING SHALL BE 16" ON CENTER. THE LOWEST STEP SHALL BE NOT MORE THAN 2 FT. ABOVE THE INVERT.
- 9- RINGS, REDUCERS, AND PIPE FOR ACCESS SHAFT SHALL BE SEATED IN CEMENT MORTAR AND NEATLY POINTED OR WIPED INSIDE SHAFT.
- 10- FLOOR OF MANHOLE SHALL BE STEEL-TROWELED TO SPRING LINE.
- 11- BODY OF MANHOLE, INCLUDING SPUR, SHALL BE POURED IN ONE CONTINUOUS OPERATION, EXCEPT THAT THE CONTRACTOR SHALL HAVE THE OPTION OF PLACING AT THE SPRING LINE A CONSTRUCTION JOINT WITH LONGITUDINAL KEYWAY.

* USE D₁ OR D₂, WHICHEVER IS GREATER, OR B.

** IF D₂, D₁, OR B FALLS BETWEEN TABULATED VALUES THEN USE THE NEXT HIGHEST VALUE TO DETERMINE F OR T.

TABLE OF VALUES FOR F AND T

X D ₁ , D ₂	F	B	T	B	T
12"	4"	12"	4"	78"	11 3/4"
15"	4 1/4"	15"	4 1/4"	84"	12 1/2"
18"	4 1/2"	18"	4 1/2"	90"	13 1/4"
21"	5"	21"	5"	96"	14"
24"	5 1/4"	24"	5 1/4"	102"	15 1/2"
27"	5 1/2"	27"	5 1/2"	108"	16"
30"	6"	30"	6"	114"	16 1/2"
33"	6 1/4"	33"	6 1/4"	120"	17"
36"	6 1/2"	36"	6 1/2"	126"	17"
39"	7"	39"	7"	132"	17 1/2"
42"	7 1/2"	42"	7 1/2"	138"	17 1/2"
45"	7 3/4"	45"	7 3/4"	144"	18"
48"	8"	48"	8"		
51"	8 1/2"	51"	8 1/2"		
54"	9"	54"	9"		
57"	9 1/4"	57"	9 1/4"		
60"	9 1/2"	60"	9 1/2"		
63"	10"	63"	10"		
66"	10 1/4"	66"	10 1/4"		
69"	10 3/4"	69"	10 3/4"		
72"	11"	72"	11"		
78"	11 3/4"				
84"	12 1/2"				
90"	13 1/4"				
96"	14"				
102"	15 1/2"				
108"	16"				
114"	16 1/2"				
120"	17"				
126"	17"				
132"	17 1/2"				
138"	17 1/2"				
144"	18"				

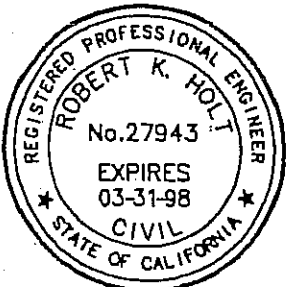

APPROVED: _____ DATE _____

APPROVED: TOWN ENGINEER
Robert K. Holt R.C.E. 27943



Town of
Yucca Valley

STORM DRAIN
 MANHOLE NO. 4

STANDARD DRAWING NO. 493A

REVISION BY DATE

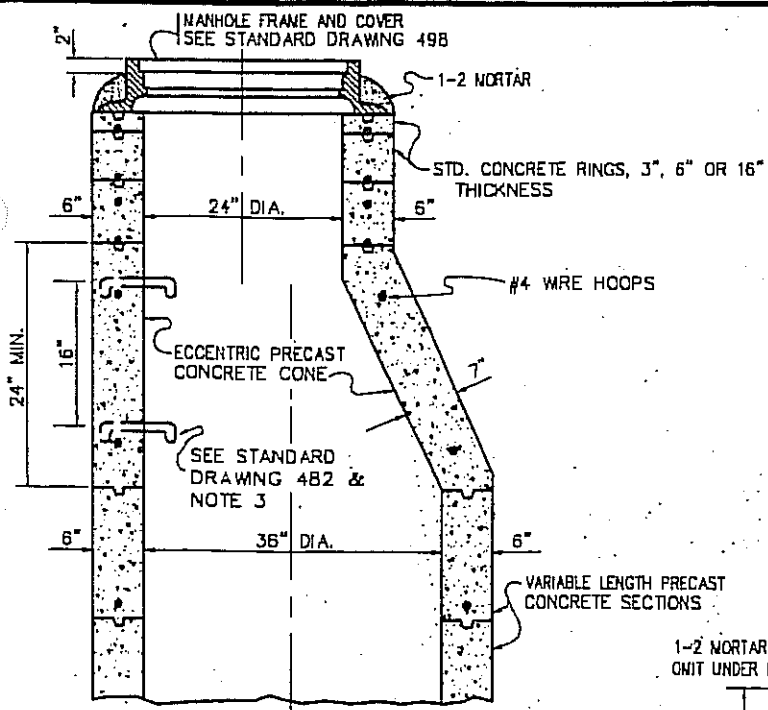

VERTICAL SECTION OF PLAIN CONCRETE ECCENTRIC MANHOLE SHAFT

NOTES:

1. ALL JOINTS SHALL BE FILLED WITH 1-2 MORTAR AND NEATLY POINTED OR WIPED INSIDE OF SHAFT.
2. COLLAR OF 1-2 MORTAR AROUND COVER FRAME SHALL BE OMITTED IN ROCK AND OIL STREETS AND IN PAVED STREETS.
3. STEPS SHALL BE 3/4 INCH ROUND GALVANIZED STEEL. TOP STEP SHALL BE PLACED DIRECTLY BENEATH THE MANHOLE COVER FRAME. WIDTH OF ALL STEPS SHALL BE 14 INCHES BETWEEN LEG CENTERS. EXCEPT WHERE SHOWN OTHERWISE, SPACING OF STEPS IN SHAFT SHALL BE 16 INCHES ON CENTER.
4. ECCENTRIC MANHOLE SHAFT, REDUCER, AND RINGS MAY BE PLAIN CONCRETE. FOR UNREINFORCED SECTIONS, THE MINIMUM THICKNESS SHALL BE 6 INCHES. THE CONCRETE USED SHALL BE CLASS "A".

2 1/2 INCH RINGS SHALL BE REINFORCED WITH TWO 1/4" ROUND STEEL HOOPS; 6 INCH AND 8 INCH RINGS SHALL BE REINFORCED WITH FOUR HOOPS, TIED WITH #14 A.S. & W. GAUGE WIRE 8 INCHES ON CENTERS

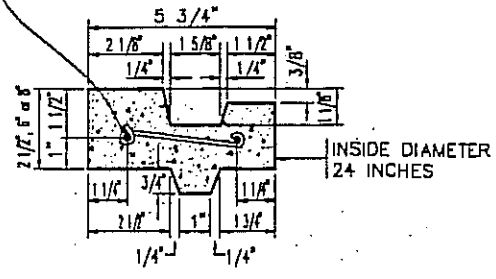

CROSS SECTION OF REINFORCED CONCRETE RING

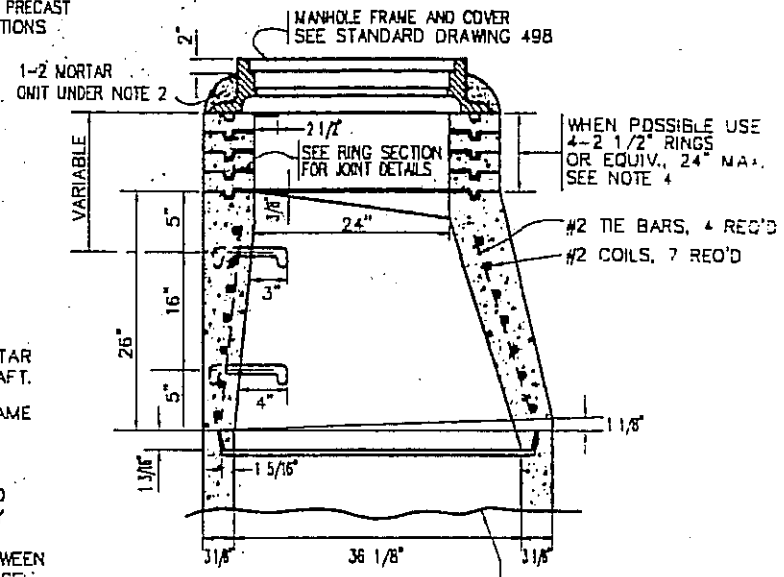

VERTICAL SECTION OF REINFORCED CONCRETE ECCENTRIC MANHOLE SHAFT

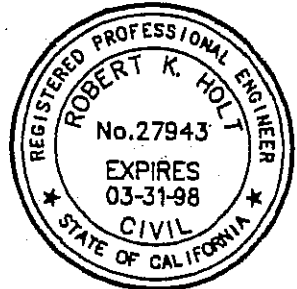

APPROVED: _____ DATE _____

APPROVED: TOWN ENGINEER
Robert K. Holt
 R.C.E. 27943

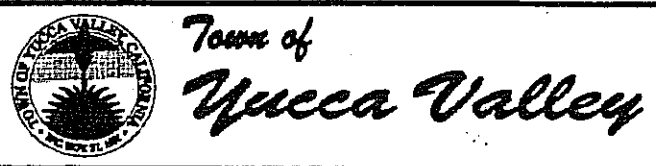

MANHOLE SHAFT FOR CAST PIPE

STANDARD DRAWING NO. 494

REVISION	BY	DATE

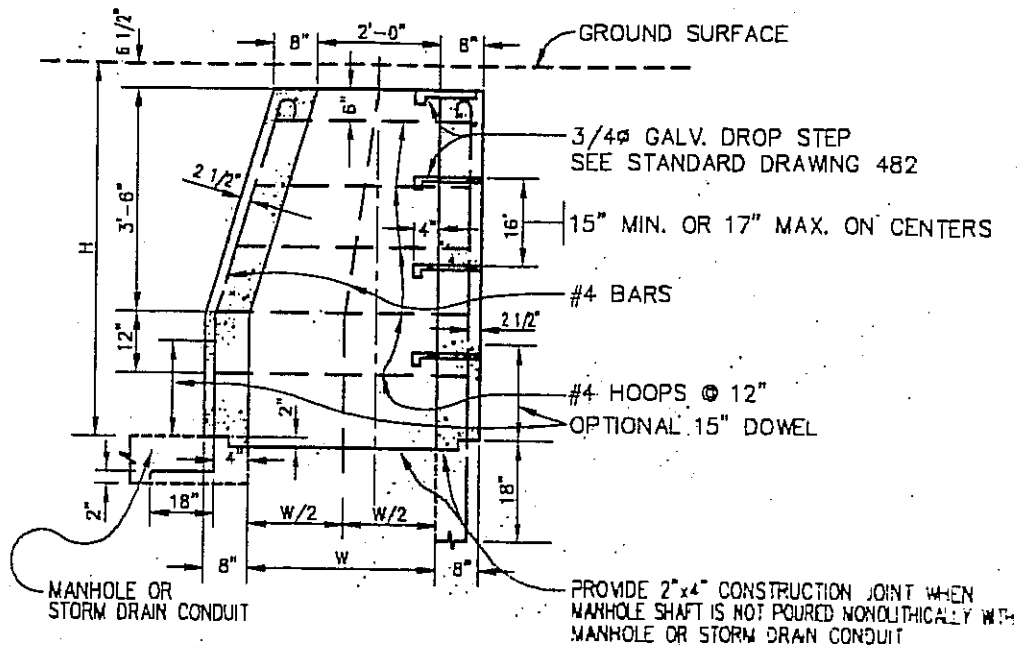

SECTION A-A

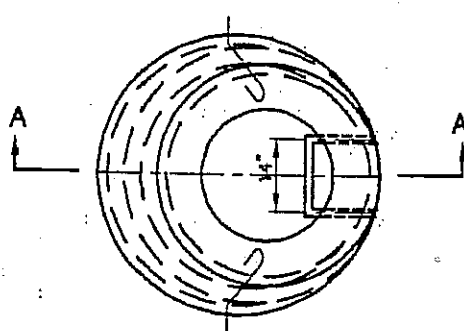

PLAN

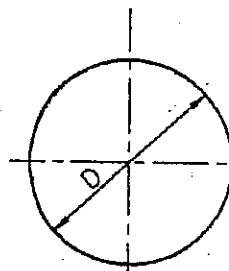

#4 HOOP BARS

WHERE H IS MORE THAN 4'-0", D=3'-1 3/4" FOR TOPMOST HOOP IN SHAFT; EACH LOWER HOOP IN SUCCESSION INCREASES 3 1/2" IN DIAMETER TO A MAXIMUM OF 4'-0" IN THE VERTICAL PORTION OF THE SHAFT.

NOTES:

- IF "H" IS LESS THAN 1'-6", W=2'-0"
IF "H" IS BETWEEN 1'-6" AND 2'-6", W=2'-6"
IF "H" IS 2'-6" OR MORE, W=3'-0"
IF "H" IS MORE THAN 4'-0 1/2", BRING WALLS VERTICALLY TO 4'-0 1/2" BELOW SURFACE AND TAPER FROM 3'-0" TO 2'-0" AS SHOWN.
- THIS STRUCTURE SHALL BE USED WITH STANDARD PRESSURE MANHOLE FRAME AND COVER. SEE STD. DWG. 499. IT MAY BE USED FOR HYDROSTATIC HEADS UP TO 25' ABOVE THE STEEL PLATE.
- CONCRETE SHALL BE CLASS "A".

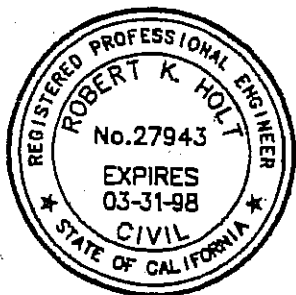

APPROVED:

DATE

APPROVED: TOWN ENGINEER

Robert K. Holt

R.C.E. 27943



Town of Yucca Valley

STANDARD PRESSURE
MANHOLE SHAFT

REVISION

BY DATE

STANDARD DRAWING NO. 495

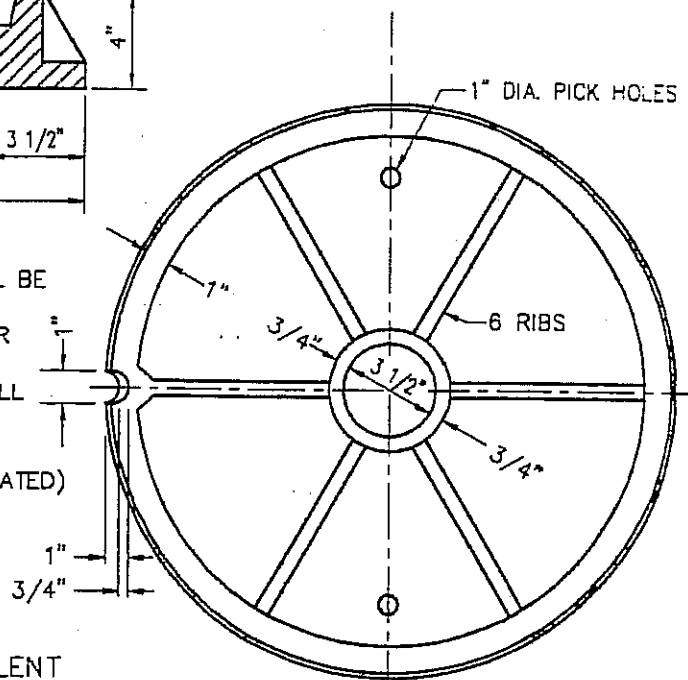
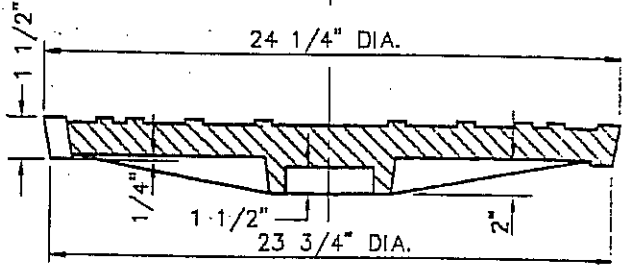
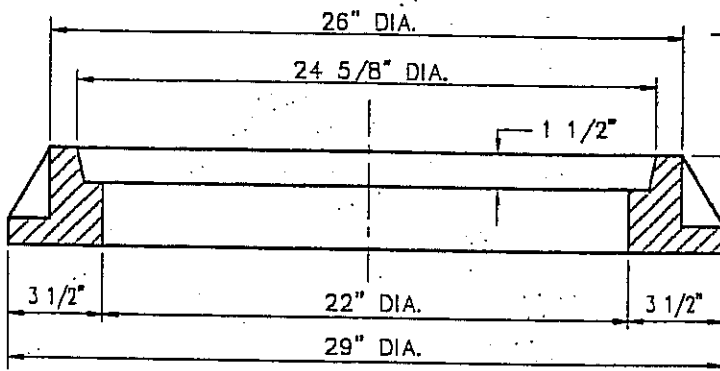
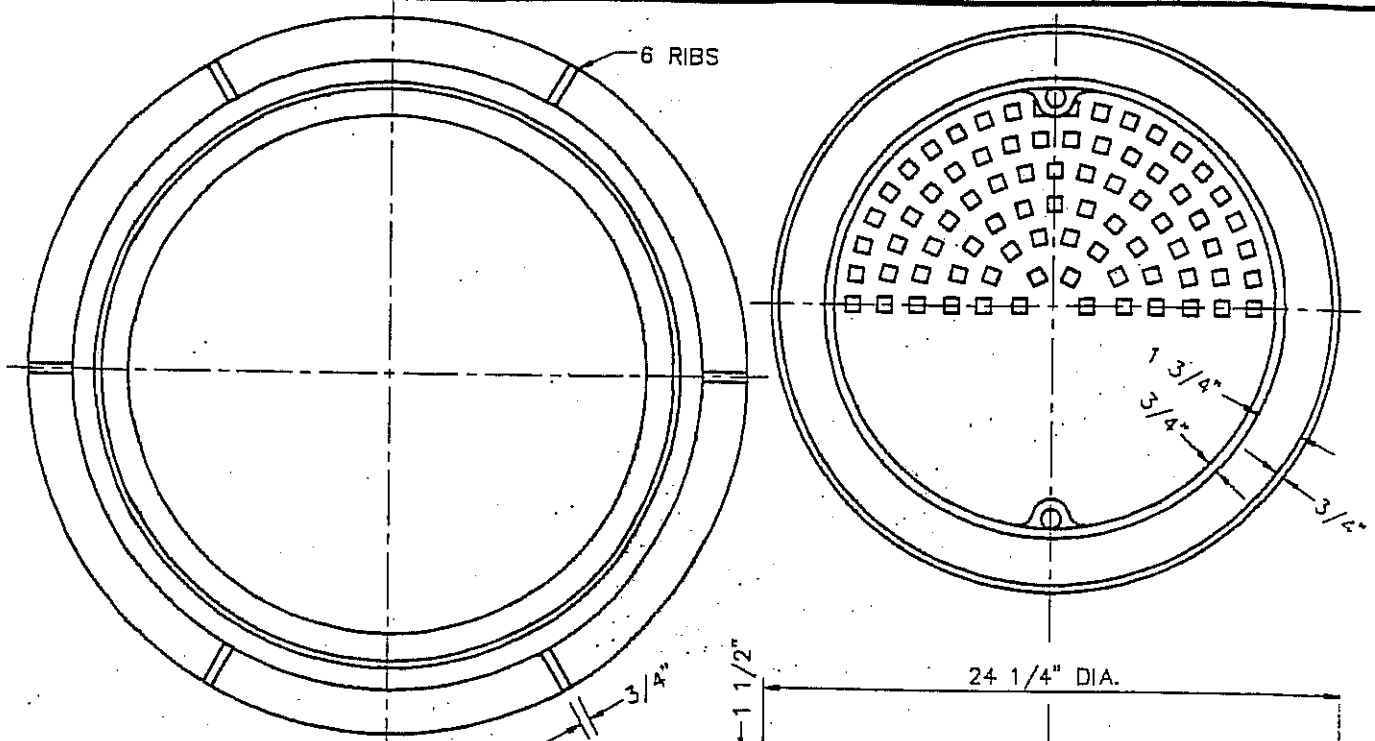

NOTES:

1. SEATS OF FRAME AND COVER SHALL BE MACHINED TO PREVENT NOISE
2. TOTAL WEIGHT OF FRAME AND COVER APPROX. 380 LBS.
3. MINIMUM CLEAR OPENING 22" DIA. ALL OTHER DIMENSIONS ARE NOMINAL

MATERIAL: CAST IRON (ASPHALT COATED)

ALHAMBRA A-1310 OR EQUIVALENT

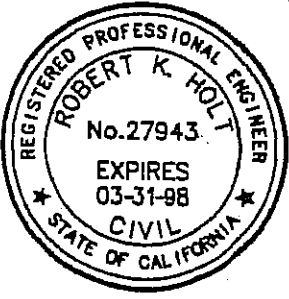

APPROVED:

_____ DATE _____

APPROVED: TOWN ENGINEER

Robert K. Holt

R.C.E. 27943



Town of Yucca Valley

MANHOLE FRAME &
COVER - ROADWAY

STANDARD DRAWING NO. 496

REVISION	BY	DATE

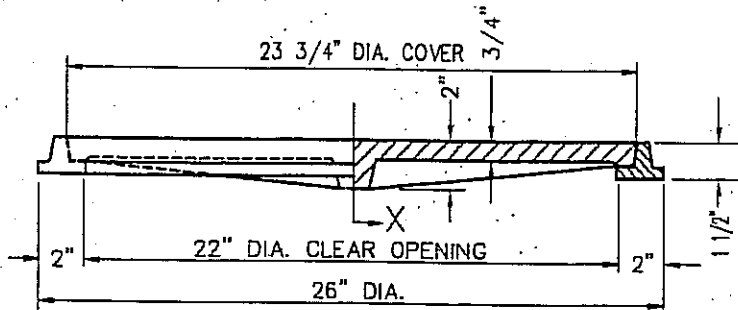
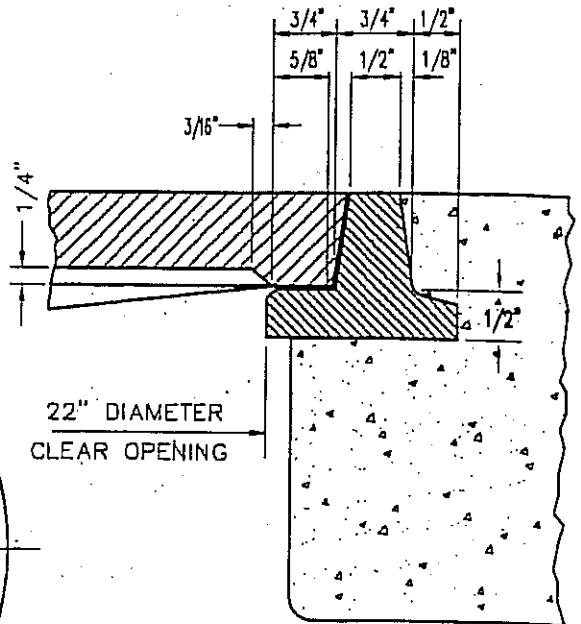
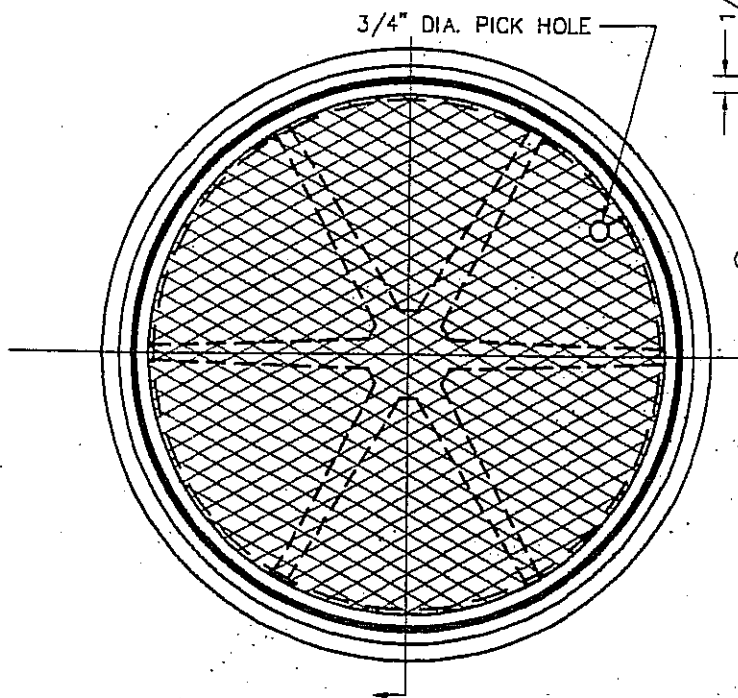

MATERIAL: CAST IRON (ASPHALT COATED OR GALVANIZED)

NOTES:

1. SEATS OF FRAME AND COVER SHALL BE MACHINED TO PREVENT NOISE.
2. TOTAL WEIGHT OF FRAME AND COVER APPROX. 130 LBS.
3. MINIMUM CLEAR OPENING 22" DIAMETER. ALL OTHER DIMENSIONS ARE NOMINAL.

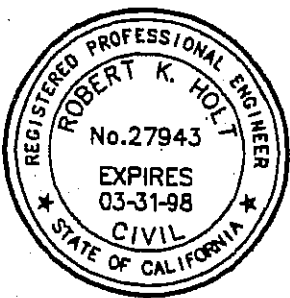

ALHAMBRA A-1530 OR EQUIVALENT

APPROVED:

DATE

APPROVED: TOWN ENGINEER

Robert K. Holt

R.C.E. 27943



Town of
Yucca Valley

MANHOLE FRAME &
COVER - PARKWAY

REVISION

BY DATE

STANDARD DRAWING NO. 497

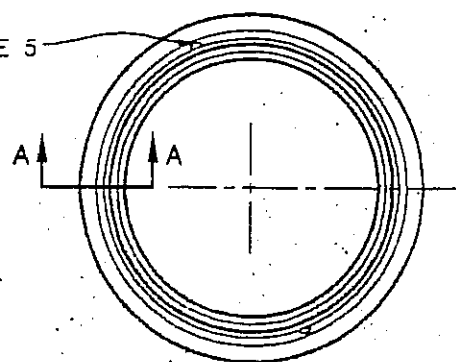
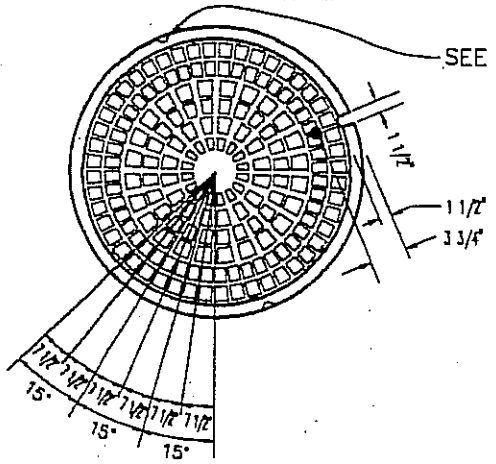
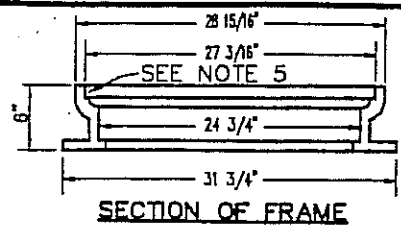
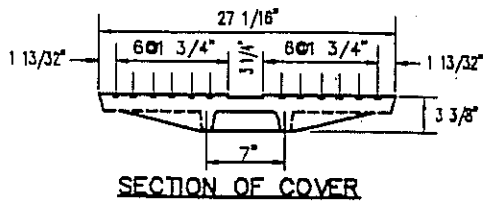

TOP PLAN OF COVER
WEIGHT=262 LBS.

PLAN OF FRAME
WEIGHT=196 LBS.

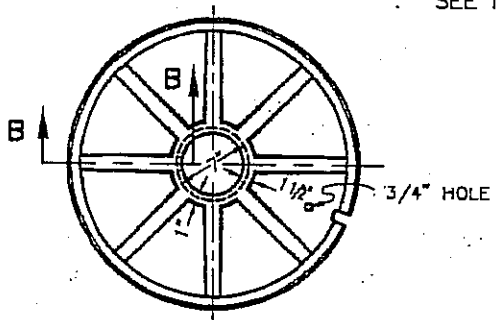

BOTTOM PLAN OF COVER

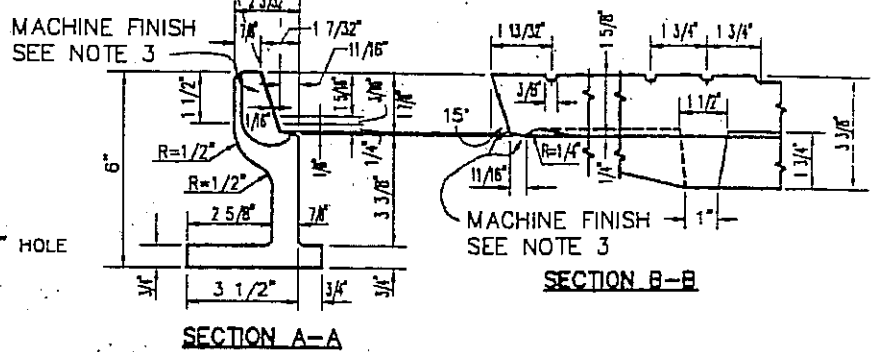

SECTION A-A

NOTES:

1. MANHOLE FRAME AND COVER SHALL BE MADE OF GRAY CAST IRON CONFORMING TO THE LATEST A.S.T.M. STANDARD A48, CLASS 30 OR BETTER.
2. ALL PARTS OF THE MANHOLE FRAME AND COVER EXCEPT MACHINED SURFACES SHALL BE COATED WITH ASPHALTUM PAINT.
3. MANHOLE FRAME AND COVER SHALL BE TESTED FOR ACCURACY OF FIT AND SHALL BE MARKED IN SETS BEFORE DELIVERY. THE COVER SHALL FIT THE FRAME SNUGLY BUT NOT TIGHTLY.
4. THE WEIGHTS OF THE FRAME AND COVER SHALL NOT VARY MORE THAN TWO PERCENT FROM THOSE GIVEN HEREON.
5. COVERS FOR MANHOLES LOCATED IN RIGHT OF WAY, EASEMENTS, ALLEYS, PARKWAYS, AND ALL OTHER PLACES EXCEPT PAVED STREETS SHALL BE PROVIDED WITH ALLEN SOCKET SET SCREW LOCKING DEVICES. THE CONTRACTOR SHALL DRILL AND TAP TWO HOLES TO A DEPTH OF 1" AT 90° TO PICK HOLE AND INSTALL 3/4"x3/4" ALLEN SOCKET SET SCREWS THEREIN.

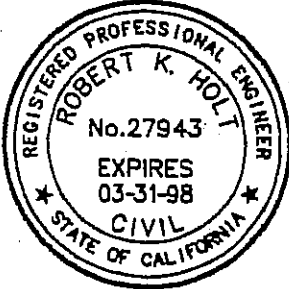

APPROVED: _____ DATE _____

APPROVED: TOWN ENGINEER
Robert K. Holt R.C.E. 27943



Town of
Yucca Valley

MANHOLE FRAME & COVER
NON-ROCKING

STANDARD DRAWING NO. 498

REVISION	BY	DATE

