

Section 3 – Utility, Street Light, and Sign Details

<u>Drawing No.</u>	<u>Description</u>
300	Street Light for Major and Arterial Streets
301	Street Light for Collector Streets
302	Street Light for Local Streets
303	Street Light Concrete Footing Details
304	Traffic Signal Pull Box Installation
305	Street Lighting General Notes
310	Fire Hydrant Location
311	Utility Valve Cover Installation
320	Underground Utility Location
321	Street Marker
322	Street Name Sign & Post

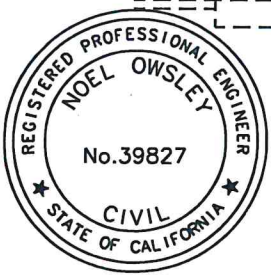
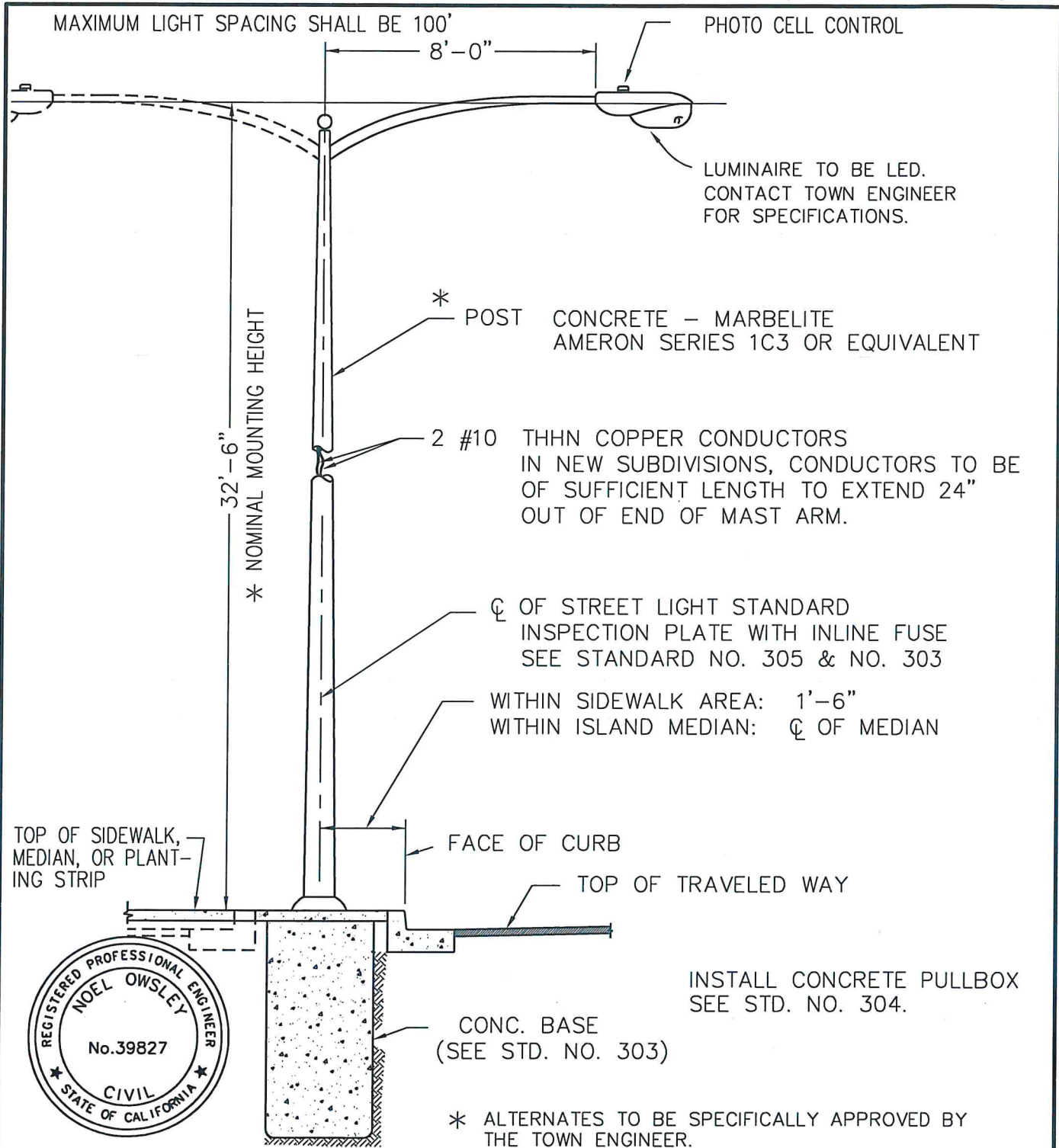

APPROVED: DIRECTOR OF PUBLIC WORKS
Alex Chishti DATE *4/21/24*

APPROVED: TOWN ENGINEER
Noel Owsley R.C.E. 39827

▲ REVISED LUMINAIRE	-N-	8/30/24
REVISION	BY	DATE



Town of
Yucca Valley

STREET LIGHT
FOR
MAJOR AND ARTERIAL STREETS
STANDARD DRAWING NO. 300

MAXIMUM LIGHT SPACING SHALL BE 200'

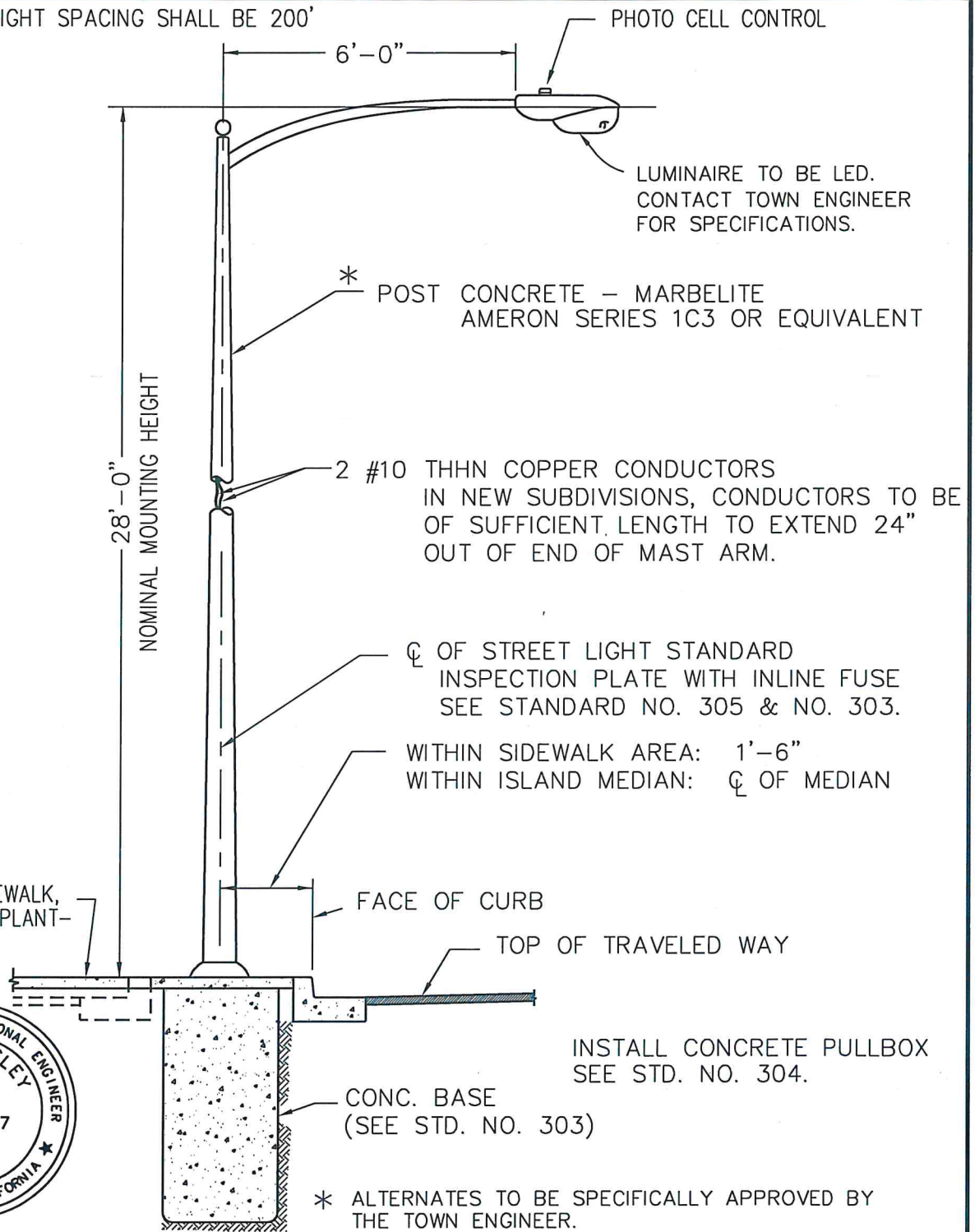

APPROVED: DIRECTOR OF PUBLIC WORKS
Alex Gicht DATE *4/21/25*

APPROVED: TOWN ENGINEER
Noel Owsley R.C.E. 39827

▲ REVISED LUMINAIRE	-N-	8/30/24
REVISION	BY	DATE



Town of
Yucca Valley

STREET LIGHT
 FOR
 COLLECTOR STREETS

STANDARD DRAWING NO. 301

MAXIMUM LIGHT SPACING SHALL BE 200'

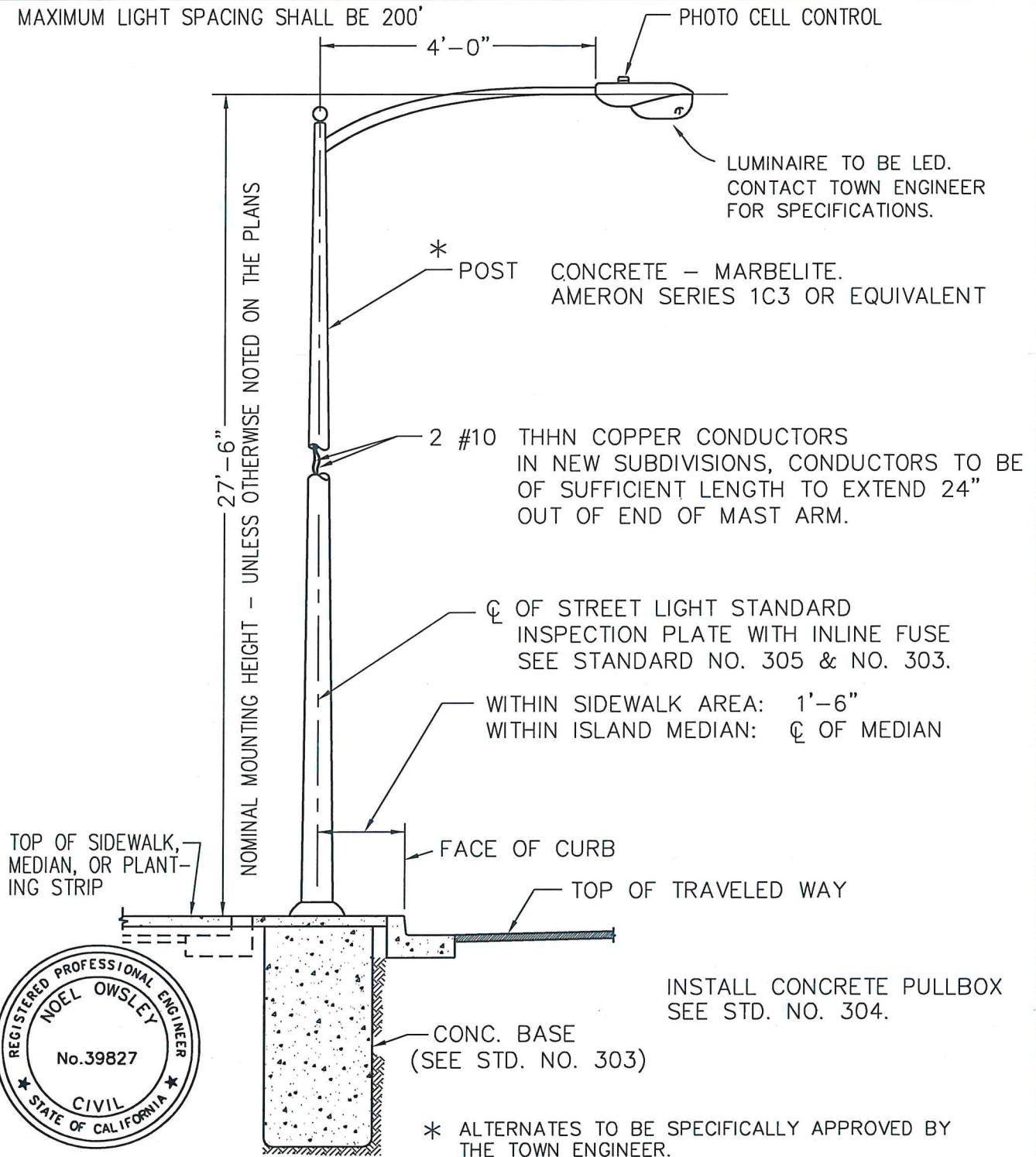

APPROVED: DIRECTOR OF PUBLIC WORKS

Alex Christa

DATE 4/21/20

APPROVED: TOWN ENGINEER

Noel Owsley

R.C.E. 39827



Town of
Yucca Valley

STREET LIGHT
FOR
LOCAL STREETS

1	REVISED LUMINAIRE	-N-	8/30/24
	REVISION	BY	DATE

STANDARD DRAWING NO. 302

SECTION

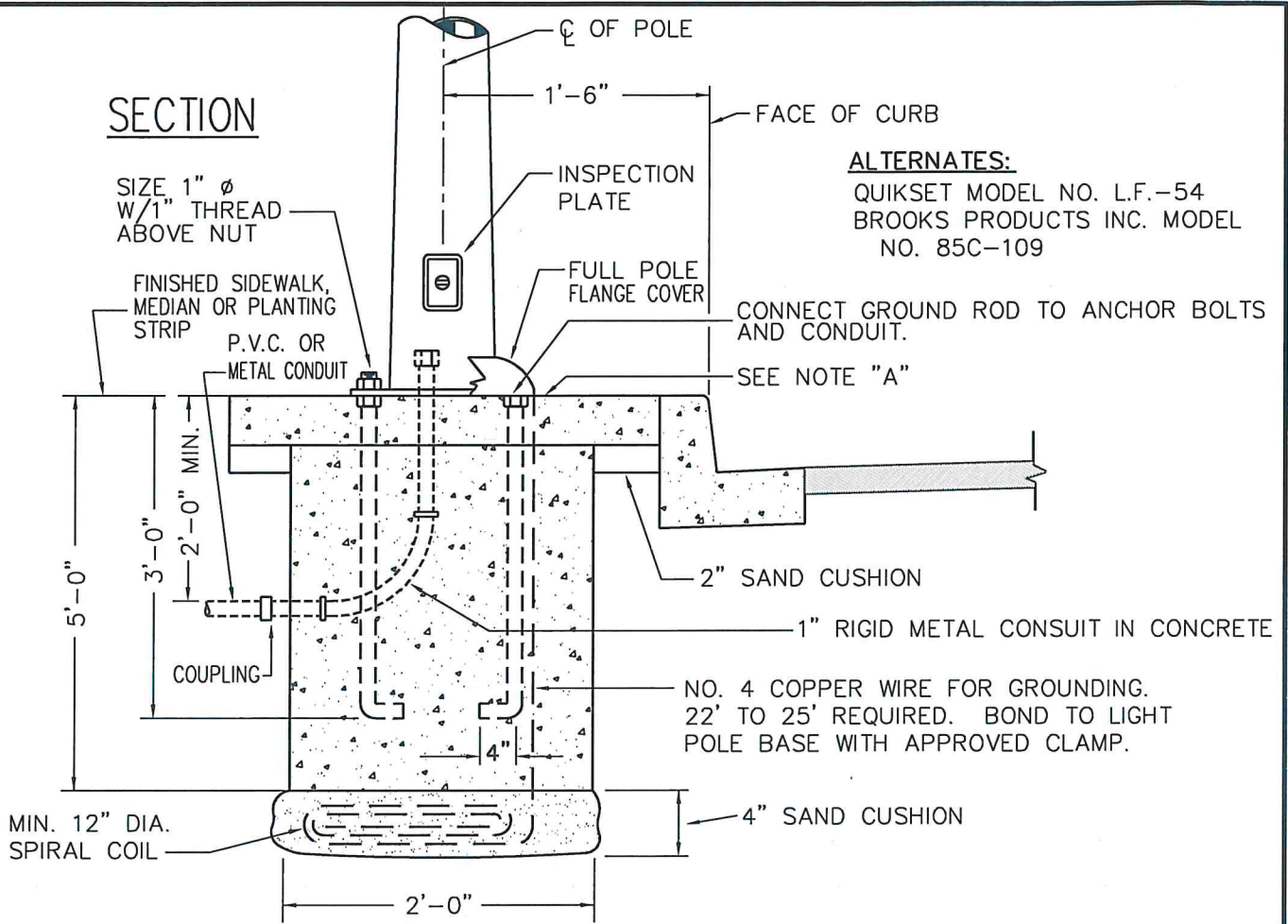

ALTERNATES:
 QUIKSET MODEL NO. L.F.-54
 BROOKS PRODUCTS INC. MODEL NO. 85C-109

CONNECT GROUND ROD TO ANCHOR BOLTS AND CONDUIT.
 SEE NOTE "A"

MIN. 12" DIA. SPIRAL COIL

NO. 4 COPPER WIRE FOR GROUNDING. 22' TO 25' REQUIRED. BOND TO LIGHT POLE BASE WITH APPROVED CLAMP.

CONCRETE SHALL BE CLASS "A" P.C.C. POUR AGAINST UNDISTURBED SOIL.

PLAN

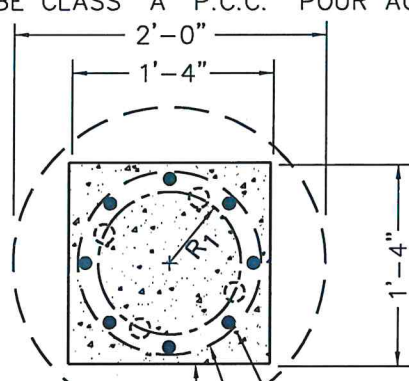

NOTES:
 A. IN UNDEVELOPED AREAS, CONSTRUCT A 2' x 2' CONC. PAD (4" THICK). IF ROUND FOOTING IS POURED, STOP AT THE ELEVATION OF BOTTOM OF THE SIDEWALK.
 R₁ = ANCHOR BOLT DIA. DIMENSION R AND BOLT PATTERN TO SUIT POLE BASE FURNISHED.



OPTIONAL SQUARE OR ROUND FOOTING
 8 #4 VERTICAL
 #3 HOOPS @ 12" C.C.

FOOTING TO BE CONSTRUCTED BY SCE FORCES

APPROVED: DIRECTOR OF PUBLIC WORKS
Alex Nista DATE 4/21/22

APPROVED: TOWN ENGINEER
Noel Owsley R.C.E. 39827

ADDED SCE CONSTR. NOTE	-N-	8/30/24
REVISION	BY	DATE



STREET LIGHT
 CONCRETE FOOTING DETAILS

STANDARD DRAWING NO. 303

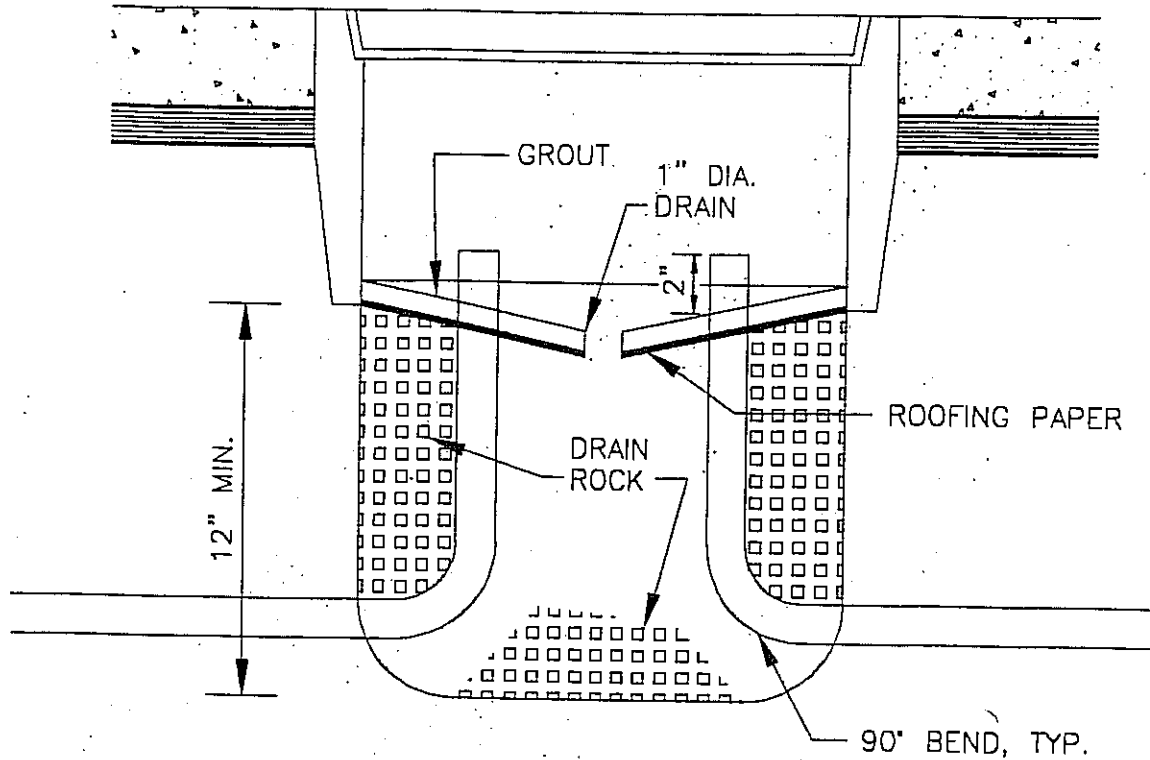

NO. 5 CONCRETE PULLBOX

NOTES:

1. DESIGN SHALL CONFORM TO THESE REQUIREMENTS EXCEPT AS OTHERWISE APPROVED BY THE TOWN ENGINEER.

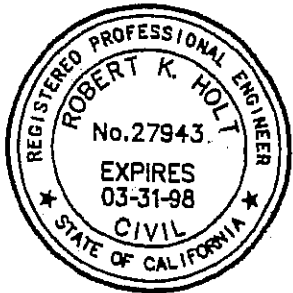

APPROVED:

DATE _____

APPROVED: TOWN ENGINEER

Robert K. Holt

R.C.E. 27943



Town of
Yucca Valley

TRAFFIC SIGNAL
PULL BOX INSTALLATION

REVISION

BY DATE

STANDARD DRAWING NO. 304

GENERAL NOTES:

1. ALL WIRING METHODS AND EQUIPMENT CONSTRUCTION SHALL CONFORM TO THE NATIONAL ELECTRICAL CODE.
2. ALL CONDUIT TO BE USED SHALL BE A MINIMUM OF 2" DIAMETER, SCHEDULE 40 P.V.C., EXCEPT FROM EACH STREET LIGHT TO ADJACENT PULL BOX WHICH MAY BE 1" DIAMETER P.V.C. OR METAL, AND SHALL HAVE THE FOLLOWING COVER FROM TOP OF CONDUIT.
 - A. WITHIN SIDEWALK OF PARKWAY AREAS: 2'-0" MIN.
 - B. WITHIN ROADWAY AREAS: 4'-0" MIN.
3. ALL METAL CONDUIT AND OTHER METAL PARTS SHALL BE CONTINUOUSLY BONDED AND GROUNDED.
4. ALL BENDS AND/OR OFFSETS SHALL BE MADE WITH FACTORY SECTIONS.
5. UNLESS OTHERWISE APPROVED BY THE TOWN ENGINEER, A NO. 5 PULL BOX (STATE STD. ES-8) SHALL BE USED AT ALL STREET LIGHT STANDARDS.
6. ALL PULL BOXES SHALL BE PER STD. 304.
7. JUNCTION BOXES TO BE NOT MORE THAN 250 FEET APART ON LONG RUNS.
8. WHEN PULL BOXES ARE SUBJECT TO VEHICULAR TRAFFIC, THEY SHALL BE SET ON ON CONCRETE FOOTINGS AND CAST IRON TRAFFIC COVERS SHALL BE INSTALLED.
9. ALL SPLICES TO BE APPROVED SOLDERLESS WATERPROOF CONNECTORS OF PROPER SIZE. (EXAMPLE: WIRENUT OR SPLIT BOLT PLUS TAPE PLUS COATING.)
10. ALL EMPTY CONDUITS SHALL HAVE A 1/4" NYLON PULL ROPE PROVIDED INSIDE.
11. ALL CONDUITS SHALL BE SEALED WITH AN APPROVED DUCT SEAL. CONDUITS STUBBED FOR FUTURE EXTENSION SHALL BE CAPPED.
12. ALL STREET LIGHTING PROJECTS ARE SUBJECT TO APPROVAL BY THE TOWN ENGINEER.
13. ALL PULLBOX COVERS SHALL BE SECURED WITH BRASS HOLD DOWN BOLTS AND INSCRIBED, "STREET LIGHTING".
14. ALL STREET LIGHTS EQUIPPED WITH A PHOTOCELL CONTROL SHALL HAVE THE PHOTOCELL ORIENTED TO THE NORTH.
15. ALL WIRE SHALL BE THHN A.W.G. WITH THE MINIMUM SIZE TO BE #8.
16. LIGHT POLES ON ALL STREETS OTHER THAN MINOR STREETS OR CUL-DE-SACS SHALL BE GALVANIZED STREET STANDARDS IN ACCORDANCE WITH TOWN STANDARD PLANS.
17. THE DEVELOPER/ENGINEER SHALL MAKE ARRANGEMENTS FOR SERVICE POINTS WITH S.C.E. THE DEVELOPER SHALL BE RESPONSIBLE FOR ALL COSTS ASSOCIATED THEREWITH WHICH SHALL BE PAID DIRECTLY TO S.C.E. THE CONTRACTOR SHALL VERIFY THE STREET LIGHT SERVICE POINT LOCATION(S) WITH S.C.E. PRIOR TO INSTALLATION.
18. DEVELOPER SHALL INSTALL, IN ACCORDANCE WITH TOWN STANDARDS GALVANIZED STEEL POLES, APPROPRIATE MAST ARM LENGTHS, AND WIRING, LEAVING 2' OF WIRING EXTENDING FROM THE MAST ARM TO ALLOW CONNECTION TO THE LUMINAIRE BY S.C.E. FORCES AT A LATER DATE.
19. NEW DEVELOPMENTS LOCATED WITHIN AN EXISTING DEVELOPED AREA SHALL INSTALL THE ENTIRE LIGHTING SYSTEM, INCLUDING LUMINAIRES.
20. ALL STREET LIGHT SYSTEMS SHALL BE DESIGNED FOR 120 VOLT SERVICES UNLESS CONNECTING TO AN EXISTING SYSTEM. IN THE LATTER CASE, THE DESIGN SHALL CONFORM TO THE SYSTEM BEING CONNECTED TO AND MUST BE SPECIFICALLY APPROVED BY THE TOWN ENGINEER.
21. THE CURRENT TO BE USED TO DETERMINE CONDUCTOR SIZE SHALL BE DETERMINED AS FOLLOWS:

$$\frac{\text{TOTAL WATTAGE OF FIXTURES SERVED}}{\text{SERVICE VOLTAGE}} \times 3.5$$



APPROVED: DIRECTOR OF PUBLIC WORKS

Alex Gisulte

DATE 4/21/22

APPROVED: TOWN ENGINEER

Noel Owsley

R.C.E. 39827

1 REVISD NOTE 18

-N- 8/30/24

REVISION

BY DATE



Town of
Yucca Valley

STREET LIGHTING
GENERAL NOTES

STANDARD DRAWING NO. 305

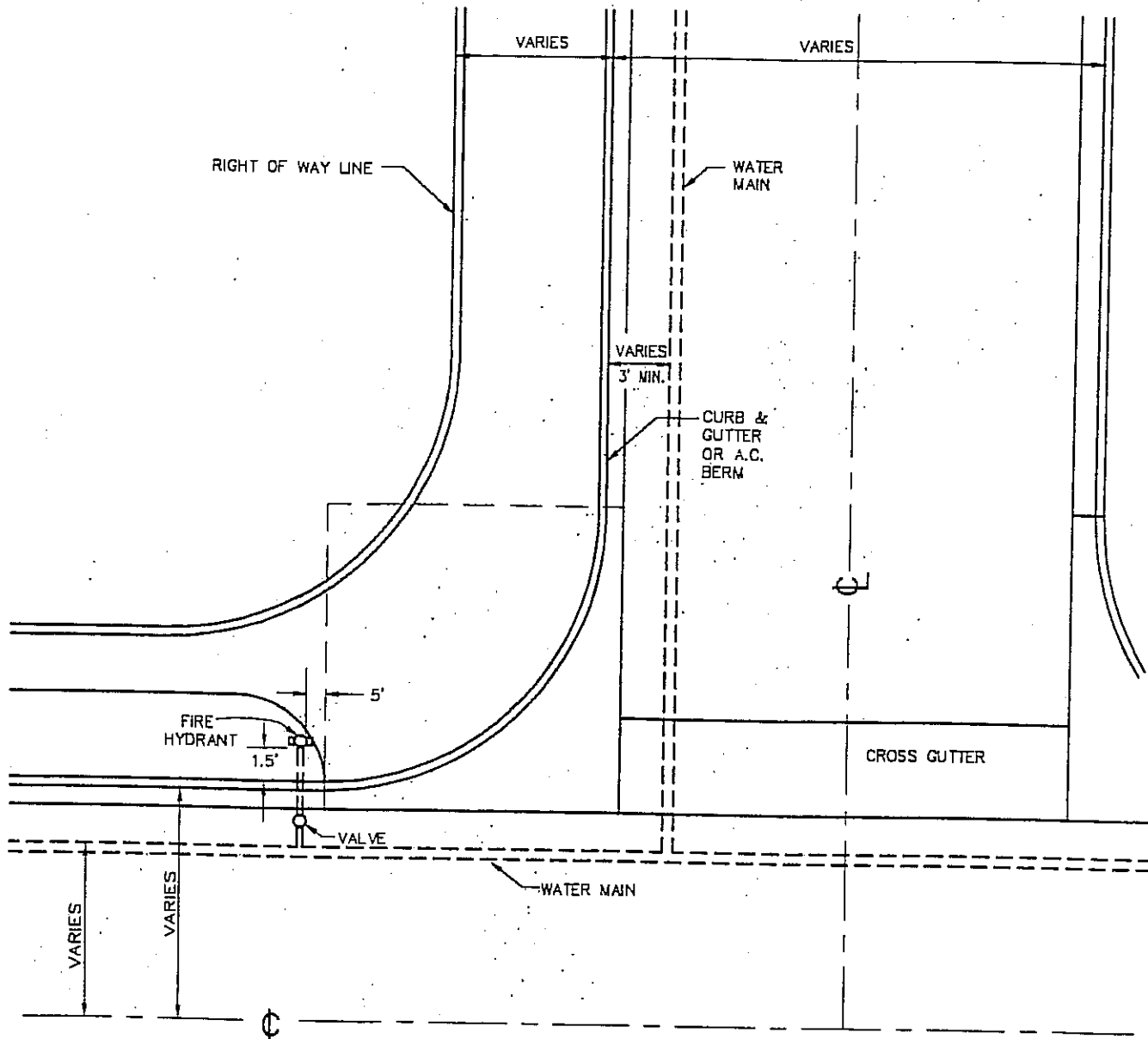

NOTES:

1. LOCATION OF WATER LINES AND VALVES SHALL BE SHOWN ON THE PLAN VIEW FOR SUBDIVISION IMPROVEMENT PLANS. SEE HEALTH DEPARTMENT STANDARDS, SECTION 7, DISTRIBUTION SYSTEMS, FOR MINIMUM DEPTH.
2. HYDRANT TO BE SET PLUMB WITH NOZZLE A MINIMUM OF EIGHTEEN (18") INCHES ABOVE GROUND LEVEL. WHEN HYDRANTS ARE PLACED BEFORE GRADING IS COMPLETED, THE FINAL GRADE LINE AND ACCESSIBILITY SHOULD BE CONSIDERED.
3. NO OBSTRUCTIONS SUCH AS POLES, GUY LINES, ETC. SHOULD BE PLACED CLOSER THAN FIVE (5') FEET TO HYDRANT.

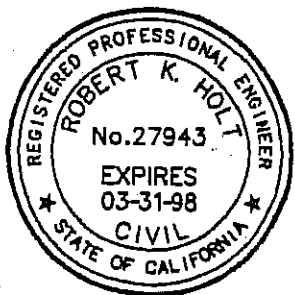

APPROVED:

DATE _____

APPROVED: TOWN ENGINEER

Robert K. Holt

R.C.E. 27943



Town of
Yucca Valley

FIRE HYDRANT
LOCATION

REVISION

BY DATE

STANDARD DRAWING NO. 310

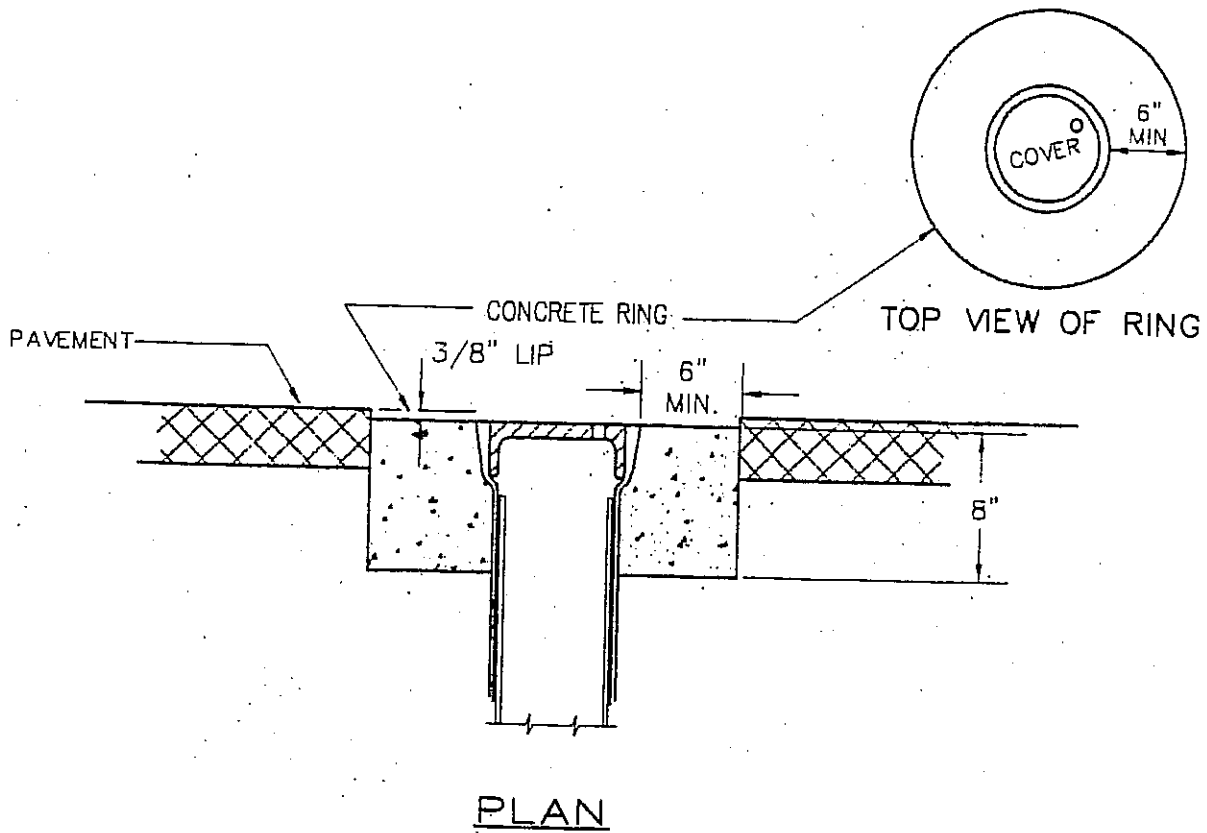

PLAN

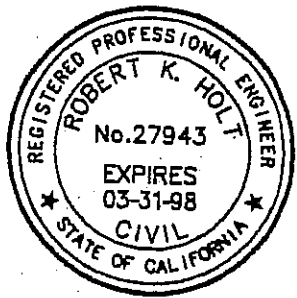

APPROVED: _____ DATE _____

APPROVED: TOWN ENGINEER
Robert K. Holt R.C.E. 27943

REVISION	BY	DATE



Town of
Yucca Valley

UTILITY
 VALVE COVER INSTALLATION

STANDARD DRAWING NO. 311

RECOMMENDED UTILITY LOCATION

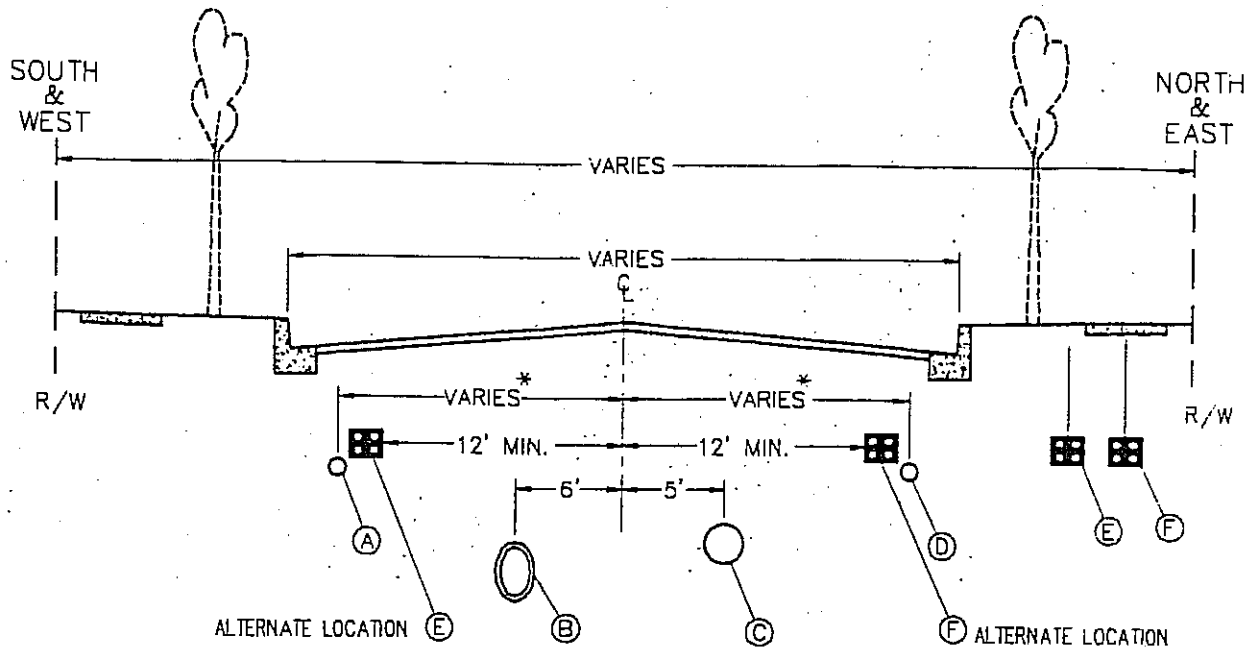

UTILITY	MIN. COVER
(A) WATER	30"
(B) STORM DRAIN	VARIES
(C) SEWER	VARIES
(D) GAS	30"
(E) POWER	36"
(F) TELEPHONE-CATV	30"

RECOMMENDED UTILITY INSTALLATION SCHEDULE

1. STORM DRAIN
2. SEWER
3. POWER & TELEPHONE
4. CURB & GUTTER
5. WATER
6. GAS
7. PAVING

NOTES:

1. WHERE ULTIMATE STREET IMPROVEMENTS ARE TO BE CONSTRUCTED, MINIMUM COVER OF UTILITY LINES MAY BE VARIED TO FACILITATE INSTALLATION.
2. THE UTILITY COMPANIES SHALL MAKE EVERY EFFORT TO LOCATE THEIR FACILITIES IN THE RECOMMENDED LOCATIONS, PARTICULARLY IN NEW SUBDIVISIONS.
3. EDISON AND TELEPHONE UTILITIES MAY USE A COMMON TRENCH. ALTERNATE LOCATION MAY BE EITHER THE EDISON POSITION OR THE TELEPHONE POSITION.
- * 4. VARIES 3' FROM THE CURB FACE TO 14' FROM C.
5. THE CENTER 24' OF STREET SHALL BE RESERVED FOR SEWER AND STORM DRAIN INSTALLATION.
6. SURFACE OF VAULT OR MANHOLE MUST MATCH PAVEMENT AND PARKWAY GRADES.
7. REPAIR OF TRENCHES AND REPLACEMENT OF PAVED SURFACING IN EXISTING ROADS SHALL BE IN ACCORDANCE WITH CURRENT "SPECIFICATIONS FOR TRENCH REPAIR."
8. WHENEVER POSSIBLE, MANHOLE COVERS SHALL NOT BE PLACED WITHIN THE SIDEWALKS.

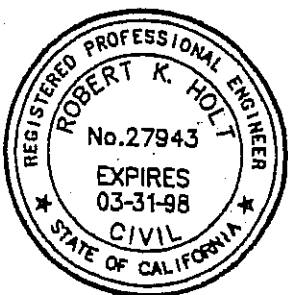

APPROVED:

DATE

APPROVED: TOWN ENGINEER

Robert K. Holt

R.C.E. 27943



Town of
Yucca Valley

UNDERGROUND
UTILITY LOCATION

STANDARD DRAWING NO. 320

REVISION

BY DATE

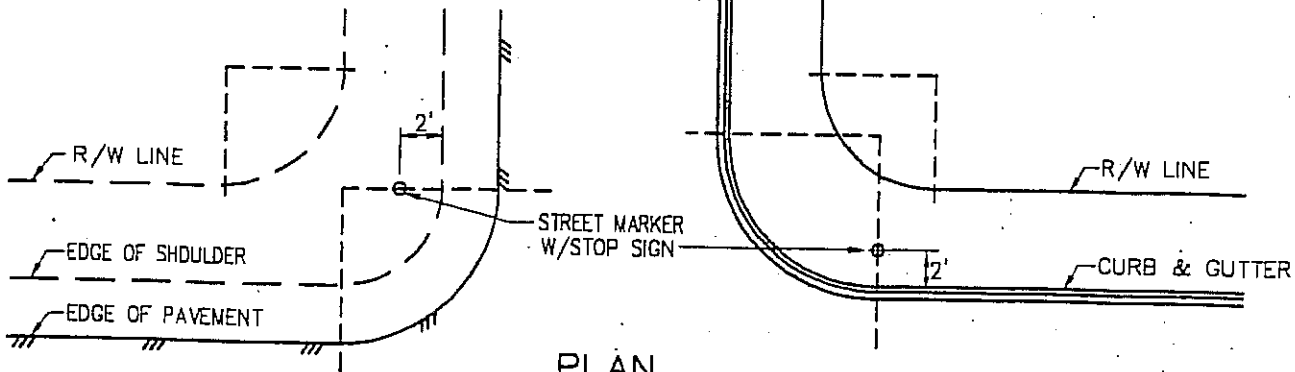

PLAN

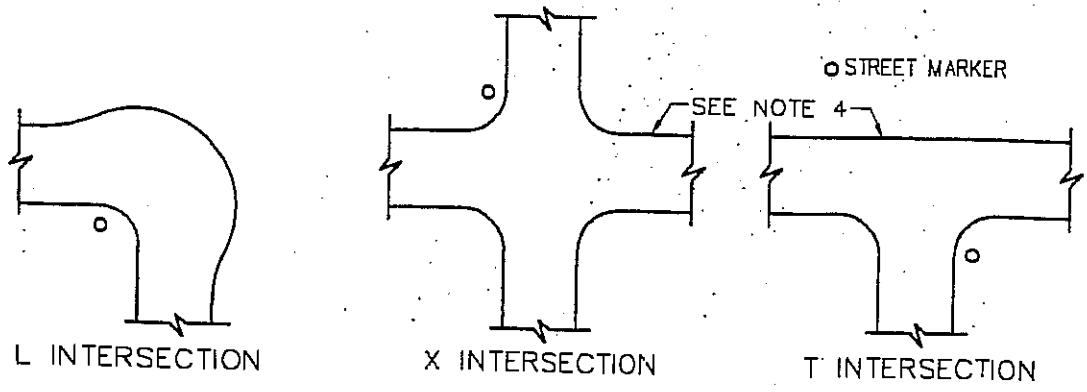

TYPICAL LOCATION

NOTES:

1. MARKER TO BE SET ON TOWN RIGHT OF WAY.
2. LOCATION OF MARKER SHOWN IS APPROXIMATE.
3. MARKERS TO BE VISIBLE FOR A DISTANCE OF 150 FEET.
4. IF EITHER ROAD IS DIVIDED INTO 4 LANES OR MORE (MAJOR ROAD), ADDITIONAL MARKERS WILL BE REQUIRED.
5. STREET MARKERS LOCATED AT MAJOR INTERSECTIONS WILL BE MOUNTED ON 12 FOOT POSTS TO ACCOMMODATE A STOP SIGN.

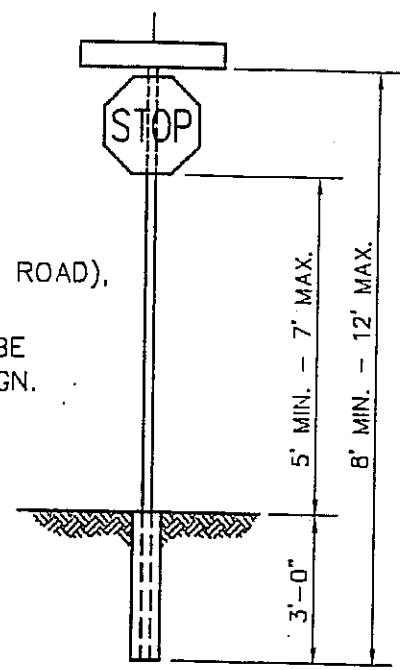

ELEVATION

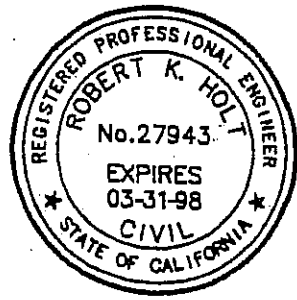

APPROVED: _____ DATE _____

APPROVED: TOWN ENGINEER
Robert K. Holt R.C.E. 27943



Town of
Yucca Valley

STREET MARKER

REVISION	BY	DATE

STANDARD DRAWING NO. 321

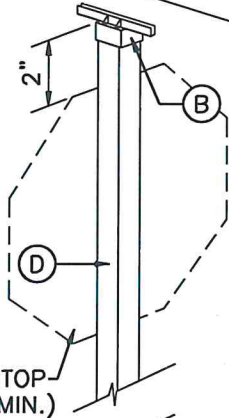
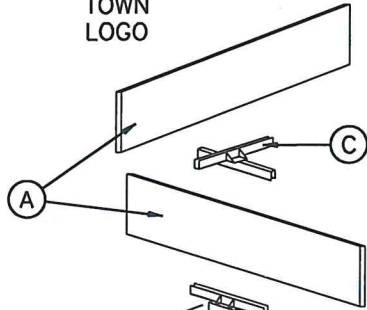
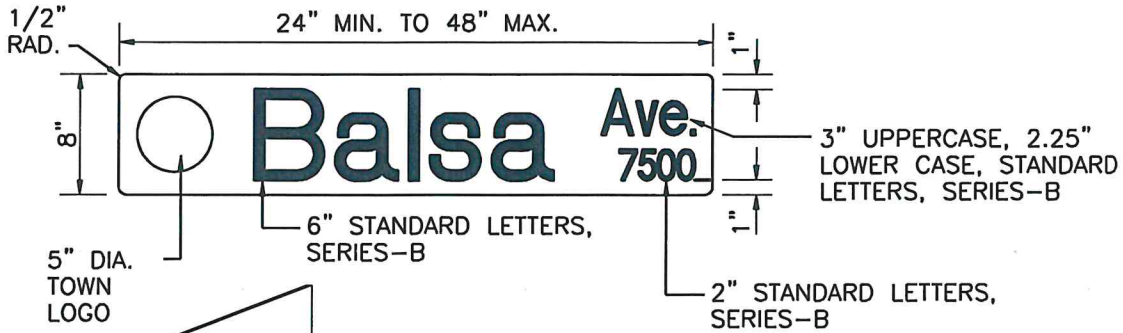

OPTIONAL STOP SIGN (30" MIN.)

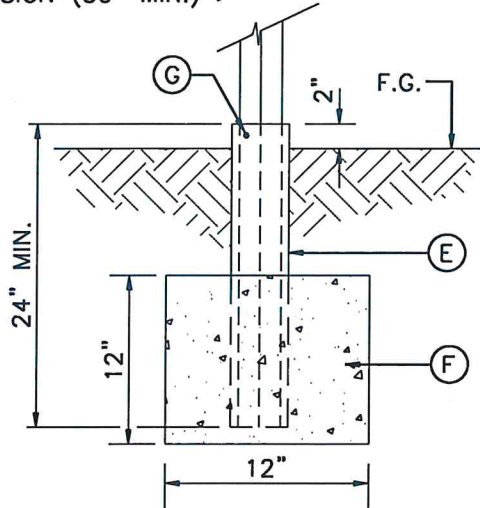

- (A) 8" FLAT BLADE SIGN BLANK
- (B) ONE PIECE CAST ANODIZED ALUMINUM POST CAP WITH SIX 3/8" STAINLESS STEEL ALLEN HEAD SET SCREWS.
- (C) ONE PIECE ANODIZED ALUMINUM CENTER CROSS SADDLE WITH FOUR 3/8" STAINLESS STEEL ALLEN SET SCREWS
- (D) 2" SQUARE QUICK PUNCH POST (L=10')
- (E) 2-1/4" SQUARE SOLID GALVINIZED POST BASE
- (F) ONE CUBIC FOOT MIN. PCC (520-C-2500)
- (G) DRIVE RIVETS OR BOLT IN CENTER OF POST, APPROX. 1" FROM TOP OF POST BASE

NOTES

ALL LETTERS, NUMBERS AND LOGOS SHALL BE WHITE, ENGINEER GRADE, 3M SCOTCHLITE HEAT-ACTIVATED REFLECTIVE SHEETING (O.A.E.)

THE SIGN BACKING SHALL BE BLUE, ENGINEER GRADE, 3M SCOTCHLITE HEAT-ACTIVATED REFLECTIVE SHEETING (O.A.E.)

SIGN BLANKS SHALL BE FLAT BLADE CONSTRUCTED OF 1/8 INCH (0.125") THICK ANODIZED ALUMINUM

APPROVED: DIRECTOR OF PUBLIC WORKS

Alex Crist DATE 4/21/25

APPROVED: TOWN ENGINEER

Noel Osley R.C.E. 39827

ADDED NEW STANDARD -N- 8/30/24

REVISION BY DATE



Town of
Yucca Valley

STREET NAME SIGN
AND POST

STANDARD DRAWING NO. 322