

March 12, 2025

Erik Nobel
Barghausen Consulting Engineers
18215 72nd Avenue South
Kent, WA 98032

**RE: CONDITIONAL USE PERMIT, (CUP) 02-25,
 ENVIRONMENTAL ASSESSMENT, (EA) 03-25
 DUTCH BROS, APN 0601-416-05**

Mr. Nobel:

Thank you for submitting the above referenced application which the Town of Yucca Valley received a deposit payment for on February 19, 2025. In accordance with Government Code Section 65943, the Town has thirty (30) days within which to notify an applicant, in writing, that an application is complete or that additional materials will be required. The thirty (30) day review period ends on March 21, 2025.

The application is deemed incomplete due to the outstanding submittal items listed below.

1. **Application**
 - a. Please completely fill out Owner/Applicant Authorization form (see attached).
2. **Grant Deed**
3. **Materials Board** – physical/tactile materials board.
4. **Utility Plan**
5. **Utility Service Availability Letters**
6. **Environmental Studies**

Please note that the following environmental studies may be prepared by the applicant or by the Town-selected consultant preparing the California Environmental Quality Act (CEQA) documentation and review. Please provide a response in writing as to whom you prefer to prepare the technical studies identified below.

Planning
(760) 369-6575
Public Works
(760) 369-6579
Building and Safety
(760) 365-0099
Code Compliance
(760) 369-6575
Engineering
(760) 369-6575
Animal Control
(760) 365-1807
Animal Shelter
(760) 365-3111
FAX (760) 228-0084



The Town of
Yucca Valley

COMMUNITY DEVELOPMENT/PUBLIC WORKS DEPARTMENT
58928 Business Center Dr.
Yucca Valley, California 92284

- a. Technical environmental studies to inform and support the environmental findings of the California Environmental Quality Act (CEQA) analysis are required. Technical studies provided by the project applicant are subject to peer review by the Town's selected consultant(s).
 - i. Traffic Analysis – Including analysis of Vehicle Miles Traveled (VMT), Average Daily Traffic (ADT), Level of Service (LOS), Circulation, and Parking. If you choose to prepare the traffic analysis, please provide the attached Traffic Scoping Form prior to initiating the study.
 - ii. Air Quality and Greenhouse Gas Analysis.
 - iii. Noise Study – including an analysis of construction activities, parking, drive-through operations, and roadway noise.
 - iv. Cultural Resources Study.
 - v. Biological Assessment – Addressing, at a minimum, the Burrowing Owl, Western Joshua Tree, and Desert Tortoise.
 - vi. Geotechnical/Soils Report.
 - vii. Hydrology Study prepared by a registered Civil Engineer.

Preliminary Comments/Corrections:

Below is a list of preliminary corrections as staff performed your completeness review. The corrections are not intended to be comprehensive but are provided as a courtesy during the completeness review. Please note that additional comments may be anticipated based on additional materials provided.

1. Site Plan

- a. Please illustrate setback distances from proposed structure to each property line.
- b. Please illustrate 3-bin trash enclosure accommodating organic waste.
- c. Please clarify which signs are menu boards to illustrate compliance with Section 9.14.030 of the Town's Development Code.
- d. Per 9.14.030(I), each drive-through aisle requires be appropriately screened with a combination of landscaping, low walls, and/or berms at a minimum of 36" to prevent headlight glare from impacting adjacent streets, properties, and parking lots. Please identify how drive-through is screened for headlight glare.
- e. Please illustrate existing and ultimate right-of-way dimensions and travel lanes.
- f. Please correct Construction Note #14 to reflect compliance with double striping standards in Section 9.33.070(C).

2. Preliminary Grading Plan

- a. Please illustrate dimensions of rear (south) driveway.
- b. Please clearly illustrate existing and ultimate right-of-way dimensions and travel lanes.
- c. Please illustrate street cross sections showing existing and proposed improvements, utilities, right-of-way, etc.
- d. Illustrate street grades with arrows indicating the direction of flow.

3. Preliminary Landscape Plan

- a. Please include existing landscaping located within the front setback area.

4. Photometric Plan

- a. Light trespass is not allowed per Chapter 8.70 of the Town's Municipal Code. 0.3 foot candles is the maximum acceptable light intensity at each property line.

Additional Information

1. Development Impact Fees (DIF) may be required for the proposed project. For more information, please see the following webpage: <https://www.yucca-valley.org/our-town/departments/community-development/planning/planning-fees>
2. In-lieu fees are estimated to be \$63,761 for the future widening of Twentynine Palms Highway.
3. Dedication of sufficient right-of-way for a 6-lane divided highway with 67-foot half width per Town Standard Drawing 106 is required. It is anticipated that an additional twelve feet (12') will be required to meet the 67' standard.
2. Please contact the County of San Bernardino Environmental Health and County San Bernardino Fire District, for their standards, application requirements, and fees.
3. Early consultation with the California Department of Fish and Wildlife regarding their requirements for an Incidental Take Permit (ITP) is encouraged.

Additional comments are anticipated upon submittal of missing information and materials. As corrections and revisions are made, please ensure consistency between plan sets. Please submit these items at your earliest convenience. If you have any questions or require any additional information, please contact Planning Division staff at 760-369-6575, extension 317.

Best regards,



JARED JEROME
Associate Planner

Owner/Applicant Authorization

Applicant/Representative: I/We have reviewed this completed application and the attached material. The information included with this application is true and correct to the best of my/our knowledge. I/We further understand that the Town may not approve the application as submitted, and may set conditions of approval. Further, I/We understand that all documents, maps, reports, etc., submitted with this application are deemed to be public records. This application does not guarantee approval or constitute a building permit application. Additional fees may be required depending on additional administrative costs.

Signature: _____

Name: John Caglia

Date: 1/30/25

Property Owner: I/We certify that I/We are presently the legal owner(s) of the above described property (if the undersigned is different from the legal property owner, a letter of authorization must accompany the form). Further, I/We acknowledge the filing of this application and certify that all of the above information is true and accurate. I/We understand that I/We are responsible for ensuring compliance with conditions of approval. I/We hereby authorize the Town of Yucca Valley and or/its designated agent(s) to enter onto the subject property to confirm the location of existing conditions and proposed improvements including compliance with applicable Town Code Requirements. Further, I/We understand that all documents, maps, reports, etc., submitted with this application are deemed to be public records. This application does not guarantee approval or constitute a building permit application. Additional fees may be required depending on additional administrative costs. I am hereby authorizing

Dutch Bros (John Caglia)

to act as my agent and is further authorized to sign any and all documents on my behalf.

Signature: _____

Name: Randall K. Smith

Date: 2/5/25

The Town of Yucca Valley is hereby granted release to copy and reproduce electronically, in whole or in part, drawings and all other materials submitted with this development application including phone numbers, addresses and e-mail addresses, for the Town's regulatory, administrative, and legal functions, including sharing of information with other governmental entities and for compliance with the California Public Records Act (CPRA). If any of these statements cannot be affirmatively acknowledged, please inform the planner before submitting a development application.

Signature: _____

Name: _____

Date: _____

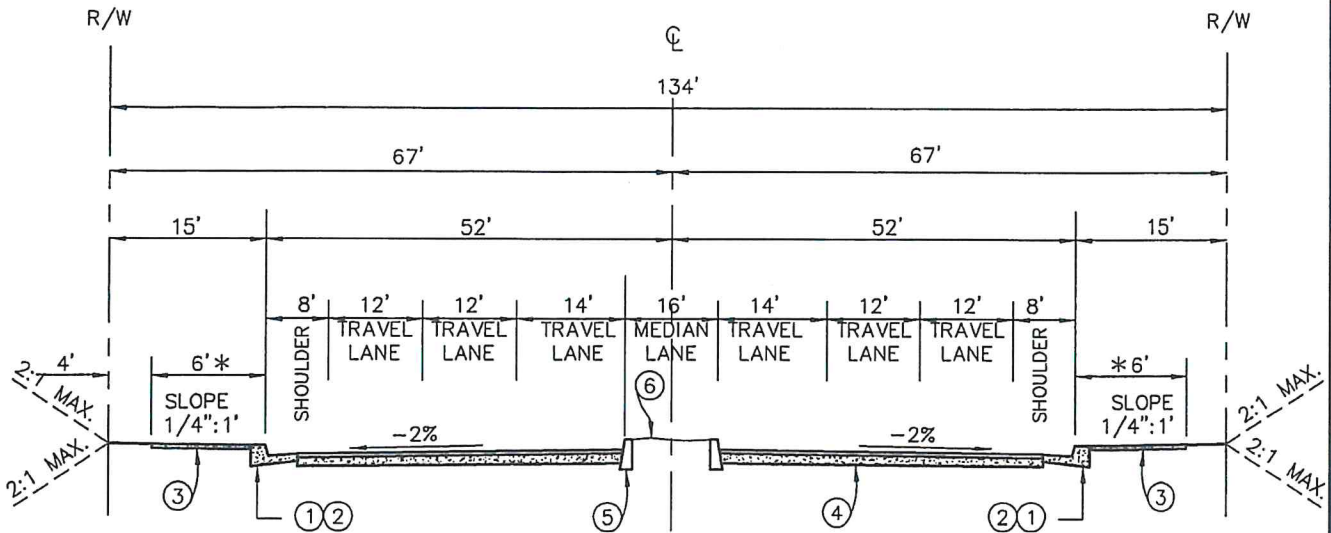

TYPICAL SECTION

NOTES:

- ① CURB AND GUTTER PER STD. DWG. NO. 200
- ② A.C. DIKE PER STD DWG. NO 202 **
- ③ SIDEWALK PER STD. DWG. NO. 220
- ④ PAVEMENT SECTION PER STD. DWG. NO. 240
- ⑤ MEDIAN CURB PER STD. DWG. NO. 200A
- ⑥ MEDIAN ISLAND LANDSCAPING PER STD. DWG. NO. 242, 242A AND 242B

* SIDEWALK REQUIREMENT PER DEVELOPMENT CODE

** LIMITED USE, SHORT TERM IMPROVEMENT PROJECTS



APPROVED: DIRECTOR OF PUBLIC WORKS

Alex Gishka DATE 11/17/16

APPROVED: TOWN ENGINEER

Noel Owsley R.C.E. 39827

▲ REVISED TO REFLECT CURRENT GENERAL PL. -N- 8/24/16

REVISION	BY	DATE



Town of
Yucca Valley

HIGHWAY
(6 LANES DIVIDED)

STANDARD DRAWING NO. 106