

**Drainage Study  
For  
Sun Mesa Road,  
Yucca Valley, CA 92284  
Datum: NAVD88**



Prepared by:  
DRP Enterprises LLC  
PO Box 4428  
Palm Springs, CA 92263

**Prepared:** November 10, 2024



# Table of Contents

---

Table of Contents.....	2
List of Exhibits.....	3
List of Attachments.....	4
List of Tables.....	5
1. Purpose and Scope.....	6
2. Background.....	7
2.1. Site Description.....	7
2.2. Existing Condition (See Exhibit A).....	7
3. Hydrology.....	8
3.1. Purpose.....	8
3.2. Methodology.....	8
Area Delineation.....	8
Discharge Calculation.....	8
Time of Concentration.....	9
3.3. Existing Condition.....	10
Basin Hydrology.....	10
Off-site Hydrology.....	12
On-site Hydrology (See Exhibit A).....	15
4. Hydraulic Analysis.....	16
4.1. Purpose.....	16
4.2. On-site Volume Mitigation Required.....	16
Calculations.....	16
4.3. Design Capture Volume.....	17
Calculations.....	17
4.4. HEC-RAS Result (See Exhibit B and Exhibit C).....	18
Basin-A Hydraulic Results.....	18
Basin-B Hydraulic Results.....	18
5. Summary and Conclusion.....	20
5.1. Hydrology.....	20
Basin Hydrology.....	20
Off-site Hydrology.....	20
On-site Hydrology.....	21
5.2. Hydraulics.....	21
On-site Volume Mitigation.....	21
Design Capture Volume (DCV).....	21
HEC-RAS Results.....	21
6. Recommendation.....	23
7. References.....	24
8. Exhibits.....	25
9. Attachments.....	42

# List of Exhibits

---

Exhibit A – Existing Condition Hydrology Map .....	25
Exhibit B – Basin-A HEC-RAS Results.....	26
Exhibit C – Basin-B HEC-RAS Results.....	27
Exhibit D – Soil Map Index.....	28
Exhibit E – Soil Group Map.....	29
Exhibit F – Time of Concentration Nomograph (Basin-A, -B, Off-A and Off-B) .....	30
Exhibit G – Pervious Curve Number (1 of 2) .....	31
Exhibit H – Pervious Curve Number (2 of 2) .....	32
Exhibit I – Land Use Impervious Cover .....	33
Exhibit J – Infiltration Rate vs SCS Curve Numbers .....	34
Exhibit K – Isohyetal Map: Desert Area 100-yr 1-Hr .....	35
Exhibit L – Isohyetal Map: Desert Area 10-yr 1-Hr .....	36
Exhibit M – Rainfall Depth vs Return Period for Partial Duration Series.....	37
Exhibit N – Intensity-Duration Curves.....	38
Exhibit O – National Flood Hazard Layer FIRMette .....	39
Exhibit P – DWR Map .....	40
Exhibit Q – NOAA Rainfall Depth .....	41

# List of Attachments

---

Attachment 1– Proposed Condition: Grading Plan..... 42  
Attachment 2 – San Bernardino County Land Use Zoning District ..... 43  
Attachment 3 – Town of Yucca Valley Flood Plain Safety Districts ..... 44

# List of Tables

---

Table 1 – Basin Time of Concentration .....	10
Table 2 – Basin Rainfall Depth .....	11
Table 3 – On-site Rainfall depth and Rainfall Intensity .....	11
Table 4 – Peak Flow Rate.....	12
Table 5 – Existing Condition: Off-A and Off-B Time of Concentration .....	13
Table 6 – Existing Condition: Off-A and Off-B Rainfall Depth .....	13
Table 7 – Existing Condition: Off-A and Off-B Rainfall depth and Rainfall Intensity.....	13
Table 8 – Existing Condition: Off-A and Off-B Peak Flow Rate .....	14
Table 9 – Summary of Peak Flow of all Basin.....	15

# 1. Purpose and Scope

---

A drainage study is required for developments exceeding 10,000 square feet or 0.23 acre as part of the Conditional Use Permit process. This report summarizes the hydrologic analyses conducted to determine the necessary drainage improvements needed to provide flood protection for the proposed development and to safely convey runoff through the site during a 100-year storm event. The study also assesses whether the 100-year storm flows from the on-site projected development will create any significant runoff.

## 2. Background

---

### 2.1. Site Description

**Location:** The project site encompasses approximately 4.34 acres and includes parcel APN 059711167, owned by the Robert Billings. It is situated in a desert area near Sun Mesa Road in Yucca Valley, California.

**Soil Classification (See Exhibit E):** According to the San Bernardino County (SBC) Hydrology Manual Soil Group Map, the project site is classified as "**Group B**" soil. In the absence of detailed site-specific soil data, this classification is applied to ensure accurate analysis. Group B soils are characterized by moderate infiltration rates when thoroughly wetted, consisting primarily of moderately deep to deep, moderately well-drained to well-drained sandy-loam soils with moderately fine to moderately coarse textures. These soils also exhibit a moderate rate of water transmission.

**Flood Plain Information (See Exhibit O and Exhibit P):** Per Firmette No. 06071C8120H, issued by the Federal Emergency Management Agency (FEMA) on June 28, 2008, the project site is designated as FEMA "**Zone X**," indicating minimal flood hazard. Although not located within the 100-year floodplain according to the Department of Water Resources (DWR) Map, the site may have some flood risk due to the presence of levees, as outlined by the National Flood Insurance Program. Additional details are provided in Exhibit O and Exhibit P.

**Zoning and Land Use (See Attachment 2 and Attachment 3):** The project site is located within the Industrial Zone of the Town of Yucca Valley. According to Section 9.10.030 of the Yucca Valley, California Code of Ordinances, the development standards for this zoning district require a minimum lot area of 5 acres, with a minimum width of 60 feet and a depth of 100 feet.

### 2.2. Existing Condition (See Exhibit A)

The project site is located in a semi-arid region with rugged desert terrain, featuring irregular slopes and varying topographic features. The soil gradient across the site varies, with the steepest slopes observed in the middle section, ranging from 6.10% to 12.50%, and in the southern section, where slopes range from 2.60% to 14.0%. The flatter areas of the site have more gradual slopes, ranging from 0.1% to 5.0%. The property spans approximately 4.34 acres, with the natural flow path directing runoff from the northwest toward the east and southeast, as shown in Exhibit A.

As depicted in Exhibit A, the basin flows into the site, splitting into two sub-basins that direct flow into the area. These sub-basins include Basin A (6.94 acres) and Basin B (10.0 acres). Additionally, the off-site portions of these sub-basins, Off-A (4.48 acres) and Off-B (7.89 acres), channel stormwater from the northwest and west toward the project site.

## 3. Hydrology

---

### 3.1. Purpose

This hydrological analysis aims to evaluate stormwater flow patterns within the existing site, as well as its contributing off-site areas. A flow path has been established, and the contributing basin has been divided into smaller sub-basins to gain a clearer understanding of localized stormwater runoff behavior. Each sub-watershed was analyzed to determine its individual contribution to the overall flow path. The peak flow for each sub-basin has been estimated in accordance with the SBC Hydrology Manual, utilizing the 100-year peak flow.

### 3.2. Methodology

#### **Area Delineation**

The project site and its surrounding area were delineated into two basins, Basin A and Basin B, which extend beyond the project boundary. Basin A and Basin B required separate analyses for both off-site and on-site areas. This study primarily aimed to determine the on-site discharge and assess the potential impact of storm events on the project area. The contour and Digital Elevation Model (DEM) data used for this analysis were obtained from the United States Geological Survey (USGS), which provided critical elevation information for accurate hydrological modeling.

#### **Discharge Calculation**

To determine the on-site discharge, the following equation was applied: the discharge of the basin ( $Q$ ) minus the off-site inflow ( $Q_{\text{offsite}}$ ). This approach considers the total discharge generated by the larger basins that extend beyond the project site (Basin-A and Basin-B). The off-site inflow, representing the portion of runoff originating from areas outside the project boundary, was subtracted from the overall basin discharge. This calculation isolates the on-site discharge, providing an accurate representation of how much runoff will affect the project area during the 100-year storm event.

By using this method, the discharge values for both on-site and off-site areas were distinguished, allowing for a focused analysis of the direct hydrological impact on the project site.

## **Time of Concentration**

The Time of Concentration (T<sub>c</sub>) and Peak Flow rates were calculated based on SBC Hydrology Manual sections D.3 and E. Section D.3 was used for drainage areas less than 640 acres, while Section E applied to areas larger than 640 acres. The methods and equations employed for these calculations are detailed in subsequent sections.

This comprehensive methodology ensured that both on-site and off-site hydrological effects were thoroughly analyzed, providing a reliable basis for understanding potential stormwater impacts on the project area.

### **Areas Less than 640 acres**

1. Determine the area (A, acres) of the total watershed tributary to the point of concentration.
2. Determine the Initial time of concentration, T<sub>c</sub>, using Figure D-1. Initial Sub-area should be less than 10 acres, have a flow path of less than 1,000 feet.
3. Using the time of concentration, determine the Intensity of rainfall in inches per hour (I) from the appropriate intensity-duration curve for the particular area using Figure D-3.
4. Calculate the area-averaged maximum loss rate, F<sub>m</sub>, which corresponds to the soil group, cover complex, and imperviousness of the drainage subarea. Loss rates for the pervious area, F<sub>p</sub>, follow from section C.6.4.
5. Compute Peak flow, Q for the point of concentration

The modified rational method formula is expressed as:

$$Q = CIA$$

$$C = 0.90 \left\{ a_i + \left[ \frac{(I - F_p)(a_p)}{I} \right] \right\}, \text{ for } I \text{ greater than } F_p$$
$$= 0.90a_i, \text{ for } I \text{ less than or equal to } F_p$$

Where,

Q = Peak discharge, in cubic feet per second (cfs)

C = Runoff Coefficient, portion of rainfall that runs off the surface (no units)

I = Average Rainfall Intensity (in inches/hour) for a duration equal to the T<sub>c</sub> for the area

A = Area of Lot in acre

*Note: If the computed T<sub>c</sub> is less than 5 minutes, use 5 minutes for the peak discharge, Q.*

### 3.3. Existing Condition

#### Basin Hydrology

Refer to Existing condition drainage patterns in Exhibit A.

Each basin was evaluated for the 100-year storm event, with peak flow rates and times of concentration (Tc) calculated to assess their contribution to the site's overall drainage and potential flood risk.

Basin-A, spanning 6.94 acres, has a flow path of 979 feet with an elevation difference of 29.70 feet. The time of concentration (Tc) for the 100-year storm event was calculated to be 9.50 minutes, resulting in a peak flow rate of 24.05 cubic feet per second (cfs). The relatively short Tc and moderate elevation change highlight the basin's potential for swift runoff response during intense storm events.

Basin-B, the largest basin, covers an area of 10 acres and features a flow path of 1,000 feet with an elevation difference of 22.80 feet. Its time of concentration (Tc) was determined to be 10 minutes for the 100-year storm event, producing a peak flow rate of 33.40 cubic feet per second (cfs). The size of this basin and its peak flow rate emphasize the importance of comprehensive flood management strategies to handle substantial runoff contributions.

Each basin was carefully analyzed to understand the flow dynamics during major storm events. The results emphasize the differing contributions of each basin, with Basin-B being the largest runoff contributor. This hydrologic analysis is crucial for designing effective flood mitigation strategies and ensuring the site's drainage system can manage stormwater runoff efficiently.

Detailed calculations are provided in the following subsection.

#### **Parameters and Calculations**

**Time of Concentration, minutes:** Time of concentration (Tc) calculations were performed using Nomograph for Determination of Time of Concentration (Tc) (based in Kirpich Formula) or Travel Time (Tt) for Natural Watersheds (**See – Exhibit F**).

Table 1 – Basin Time of Concentration

Drainage Area	Area (AC)	Flow Path (ft)	Elevation Diff (ft)	Soil Runoff Index Value	Infiltration Rate, F <sub>p</sub>	Time of Conct. (min)
Basin-A	6.94	979	29.70	56	0.268	25.90
Basin-B	10.00	1000	22.80	56	0.268	24.40

**Soil Group:** San Bernardino County Hydrology Manual was used to determine soil types. Based on San Bernardino County Hydrology Manual (**Exhibit E**), the project site is classified as 'soil type B'.

**Cover Type:** The site's land cover type was identified using Exhibit G and Exhibit H, which classifies the existing pervious land cover as "Urban Cover, Residential or Commercial Landscape." Additionally, Exhibit I recommends an impervious cover of 90% for the site.

**Rainfall Depth:** Rainfall depth are obtained from Exhibit K and Exhibit L for 100-year and 10-year 1-hour precipitation. These are then used for the estimation of 25-year rainfall depth, 1-hour using Exhibit M.

Table 2 – Basin Rainfall Depth

Storm Event	Rainfall Depth (in)
100-Year 1 hour	1.40
10-Year 1 hour	0.90

Table 3 – On-site Rainfall depth and Rainfall Intensity

Drainage Area	Impervious Cover	Slope of Intensity (Desert Area)	Rainfall Intensity (I), in/hr
Basin-A	0.90	0.70	3.92
Basin-B	0.90	0.70	3.79

**Infiltration Rate:** From the manual's Figures B-9 and B-10 (see Exhibit J) rainfall depth was estimated.

**Peak Flow, cfs:** The value for the peak flow was determined once Rainfall Data and Runoff Coefficient values were calculated using the parameters.

**For Basin-A:**

100-Yr 1-hour Precipitation depth = 1.40 inch (Exhibit K)

10-Yr 1-hour Precipitation depth = 0.90 inch (Exhibit L)

So, 25-Yr 1-hour Precipitation depth = 1.08 inch (Exhibit M)

So, 25-Yr Rainfall intensity for 9.50 min storm, I = 1.3.92 in/hr (Exhibit N)

As we discussed, 100-Yr 'existing' conditions is based on 25-Yr storm using AMC II

So, Basin-A 100-Year peak flow,  $Q = C \times I \times A = 0.90(a_i + ((I-F_p)a_p)/I) \times I \times A$

$$Q_A = 0.90 \times (0.90 + ((3.92 - 0.745 \times 0.10) / 3.92) \times 3.92 \times 6.94 = 24.05 \text{ cfs}$$

$$Q_B = 33.40 \text{ cfs}$$

The summary of the calculations of the peak flow of on-site drainage is presented below.

Table 4 – Peak Flow Rate

Drainage Area	Area (ac)	Runoff Index Values	F <sub>P</sub>	a <sub>i</sub> (%Impervious)	a <sub>p</sub> (% Perv)	Rainfall Intensity, I (in/hr)	Peak Flow, Q <sub>s</sub> (cfs)
Basin-A	6.94	56	0.745	0.90	0.10	3.92	24.05
Basin-B	6.149	86	0.268	0.90	0.10	3.79	33.40

### **Off-site Hydrology**

Refer to Existing condition drainage patterns in Exhibit A.

For the off-site hydrology analysis, the watershed was divided into two primary sections: Basin-A and Basin-B. These basins extend beyond the project site, and both the on-site and off-site portions were analyzed to determine the impact of stormwater inflow on the site. The off-site inflows, designated as Off-A and Off-B, were evaluated using the principle of conservation of energy (Q-Q<sub>in</sub>), where off-site inflow (Q<sub>in</sub>) is subtracted from the total basin discharge (Q) to isolate the on-site discharge (Q<sub>out</sub>).

#### ***Off-A (Off-site of Basin-A)***

Off-A, the off-site portion of Basin-A, encompasses a watershed area of 4.48 acres. The flow path extends 593 feet with an elevation difference of 14.60 feet, resulting in a calculated time of concentration (T<sub>c</sub>) of 8.0 minutes. For the 100-year storm event, the peak flow rate is determined to be 17.54 cubic feet per second (cfs), indicating a relatively rapid response to precipitation due to the short flow path and moderate elevation change. This highlights the significance of managing runoff efficiently to mitigate potential flooding or erosion impacts downstream.

#### ***Off-B (Off-Site Basin-B)***

Off-B, the off-site portion of Basin-B, covers a watershed area of 7.89 acres. It features a flow path of 695 feet with an elevation difference of 19.90 feet, resulting in a calculated time of concentration (T<sub>c</sub>) of 8.30 minutes. For the 100-year storm event, the peak flow rate was estimated to be 30.09 cubic feet per second (cfs). The relatively short T<sub>c</sub> and significant peak flow underscore the importance of implementing effective stormwater management strategies to address potential runoff impacts and mitigate downstream risks.

By subtracting the off-site inflows from Off-A and Off-B from the total discharge of Basin-A and Basin-B, the on-site discharge was calculated. This method allowed for a focused analysis of how the off-site portions of these watersheds affect the project site, ensuring that inflows from external areas were properly accounted for in the overall drainage design.

This off-site hydrology analysis is crucial for developing appropriate stormwater management strategies, as the inflows from surrounding areas directly influence the volume of runoff that must be managed within the project boundary.

The calculations can be seen in detail in the following sub-section.

**Parameters and Calculations**

**Time of Concentration** in minutes see Exhibit F. Table below shows the parameters needed to estimate time of concentration.

**Table 5 – Existing Condition: Off-A and Off-B Time of Concentration**

<b>Drainage Area</b>	<b>Area (AC)</b>	<b>Flow Path (ft)</b>	<b>Elevation Diff (ft)</b>	<b>Soil Runoff Index Value</b>	<b>Infiltration Rate, F<sub>p</sub></b>	<b>Time of Conct. (min)</b>
<b>Off-A</b>	4.48	593	14.60	56	0.745	8.00
<b>Off-B</b>	7.89	695	19.90	56	0.745	8.30

**Soil Group:** San Bernardino County Hydrology Manual was used to determine soil types. Based on San Bernardino County Hydrology Manual (Exhibit E), the project site is classified as ‘**soil type B**’.

**Cover Type:** The site’s land cover type was identified using Exhibit G and Exhibit H, which classifies the existing pervious land cover as "Urban Cover, Residential or Commercial Landscape." Additionally, Exhibit I recommends an impervious cover of 90% for the site.

**Rainfall Depth:** Rainfall depth are obtained from Exhibit K and Exhibit L for 100-year and 10-year 1-hour precipitation. These are then used for the estimation of 25-year rainfall depth, 1-hour using Exhibit M.

**Table 6 – Existing Condition: Off-A and Off-B Rainfall Depth**

<b>Storm Event</b>	<b>Rainfall Depth (in)</b>
<b>100-Year 1 hour</b>	1.40
<b>10-Year 1 hour</b>	0.90

**Table 7 – Existing Condition: Off-A and Off-B Rainfall depth and Rainfall Intensity**

<b>Drainage Area</b>	<b>Impervious Cover</b>	<b>Slope of Intensity (Desert Area)</b>	<b>Rainfall Intensity (I), in/hr</b>
<b>Off-A</b>	1.0	0.70	2.71
<b>Off-B</b>	1.0	0.70	2.53

**Infiltration Rate:** From the manual’s Figures B-9 and B-10 (see Exhibit J) rainfall depth was estimated.

**Peak Flow, cfs:** The value for the peak flow was determined once Rainfall Data and Runoff Coefficient values were calculated using the parameters.

100-Yr 1-hour Precipitation depth = 1.40 inch (Exhibit K)

10-Yr 1-hour Precipitation depth = 0.90 inch (Exhibit L)

So, 25-Yr 1-hour Precipitation depth = 1.08 inch (Exhibit M)

For Off-A:

So, 25-Yr Rainfall intensity for 8.0 min storm, I = 4.43 in/hr (Exhibit N)

As we discussed, 100-Yr 'existing' conditions is based on 25-Yr storm using AMC II

So, Off-A 100-Year peak flow,  $Q = C \times I \times A = 0.90(a_i + ((I-F_p)a_p)/I) \times I \times A$

$$Q_A = 0.90 \times (0.90 + ((4.43 - 0.745) \times 0.10) / 4.43) \times 4.43 \times 4.48 = 17.54 \text{ cfs}$$

$$Q_B = 30.09 \text{ cfs}$$

The summary of the off-site discharge calculations is provided below.

**Table 8 – Existing Condition: Off-A and Off-B Peak Flow Rate**

<b>Drainage Area</b>	<b>Area (AC)</b>	<b>Runoff Index Values</b>	<b>F<sub>P</sub></b>	<b>a<sub>i</sub> (% Impervious)</b>	<b>a<sub>p</sub> (% Perv)</b>	<b>Rainfall Intensity, I (in/hr)</b>	<b>Peak Flow, Qs (cfs)</b>
<b>Off-A</b>	4.48	56	0.745	0.90	0.90	4.43	17.54
<b>Off-B</b>	2.73	56	0.745	0.90	0.90	4.31	30.09

### **On-site Hydrology (See Exhibit A)**

For **Basin-A**, the total discharge was calculated to be 24.05 cubic feet per second (cfs). The inflow from the off-site portion of this basin, Off-A, was determined to be 17.54 cfs. After applying the conservation principle ( $Q - Q_{in}$ ), the on-site discharge for Basin-A is calculated at 6.51 cfs.

For **Basin-B**, the total discharge was calculated at 33.40 cfs, with an inflow from Off-B of 30.09 cfs. Using the same principle, the resulting on-site discharge for Basin-B is 3.30 cfs.

This analysis highlights that only **Basin-A** and **Basin-B** have both inflow and outflow components, meaning they significantly influence the on-site hydrology.

A summary of the peak flow rates is provided in Exhibit B, illustrating that the on-site discharges for Basin-A and Basin-B are the primary concerns for drainage management, while Basin-C and Basin-D are considered minor contributors to the overall hydrologic impact of the site. This thorough evaluation is critical for designing stormwater management strategies that effectively handle both internal and external runoff contributions.

Table 9 – Summary of Peak Flow of all Basin

<b>Drainage Area</b>	<b>Discharge, cfs</b>	<b>Off-site Flow, cfs</b>	<b>On-site Flow, cfs</b>
<b>Basin-A</b>	24.05	17.54	6.51
<b>Basin-B</b>	33.40	30.09	3.30

# 4. Hydraulic Analysis

---

## 4.1. Purpose

The purpose of this section is to evaluate and present the hydraulic measures necessary for effective stormwater management on-site, ensuring compliance with local and regulatory standards. This includes the assessment of required volume mitigation to control runoff and prevent flooding, with a focus on determining the design capture volume (DCV) and implementing appropriate on-site retention systems, such as infiltration basins.

Additionally, the section will incorporate the analysis of HEC-RAS results for the on-site runoff. The goal is to assess potential impacts from regional stormwater flows and evaluate how the site interacts with broader hydrological systems, particularly under critical storm events. This analysis will inform both the on-site mitigation strategies and any necessary adjustments to manage off-site drainage contributions effectively.

## 4.2. On-site Volume Mitigation Required

The method outlined in the San Bernardino County Hydrology Manual for estimating runoff volume from a design storm event employs an empirical factor known as the runoff curve number (CN). This factor is crucial for determining the portion of rainfall depth that converts to runoff.

For this analysis, the 2-year, 24-hour rainfall depth from NOAA is 1.53 inches. The curve number (CN) for existing conditions is 56, as specified in the San Bernardino County Hydrology Manual. Additionally, the soil storage capacity is noted to be 7.86 inches, with an initial abstraction determined to be 1.57 inches.

Using these values, the calculated runoff volume for the existing on-site conditions is approximately 4.34 acre-feet, which converts to 189,050 square feet.

See sub-section below for the detailed calculations.

### **Calculations**

So, P2-Yr 24-hour Precipitation depth = 1.53 inch (Exhibit Q)

$$S = (1000/CN) - 10 = (1000/56) - 10$$

$$S = 7.86$$

$$I_a = 0.2S = 0.20 * 7.86$$

$$I_a = 1.57$$

$$\begin{aligned}
\text{Runoff Volume pre-developed, } V_{\text{pre-dev}} &= (A/12) * \{[(P2\text{-yr } 24\text{-hr } -I_a)^2] / (P2\text{-yr } 24\text{-hr } - I_a + S)\} \\
&= (4.34/12) * \{[(1.53 - 1.57)^2] / (1.53 - 1.57 + 7.86)\} \\
&= 0.001 \text{ ac-ft} = 3.46 \text{ cf}
\end{aligned}$$

### 4.3. Design Capture Volume

In accordance with Section E.12.e of the Phase 2 MS4 Permit issued by the California State Water Resources Control Board, four alternatives are provided for calculating the Design Capture Volume (DCV) when sizing Low Impact Development (LID) features and other Best Management Practices (BMPs). For the Mojave River Watershed, the Technical Guidance for Water Quality Management Plans (WQMP) specifies that the 24-hour, 85th percentile storm event is used to calculate the DCV.

For a given site with an area of 189,050 square feet, 90% impervious surface for the recommended value for Industrial Land use by the SBC Hydrology Manual, and constants specific to the site's climatic region (1.2371) and 48-hour drawdown rate (1.963), the Design Capture Volume (as per the Mojave River Watershed guidance) is calculated to be 13,243.12 cubic feet (cf).

See calculations in detail below.

#### Calculations

DMA-A Area,  $A = 189,050 \text{ ft}^2$

Project Imperviousness,  $\text{Imp}\% = 90\% = 0.90$

Runoff Coefficient,  $(R_c) = 0.858(\text{Imp}\%)^3 - 0.78(\text{Imp}\%)^2 + 0.774(\text{Imp}\%) + 0.04 = 0.73$

1-hour rainfall depth for a 2-year return period (in),  $P_{1\text{hr}} = 0.474 \text{ in}$

Mean 6-hr Precipitation (inches),  $P_6 = P_{1\text{hr}} * C1$  (where  $C1$  is a function of site climatic region = 1.2371)

$$P_6 = 0.586 \text{ in}$$

Design capture volume,  $\text{DCV} (\text{ft}^3) = 1/12 * [A * R_c * P_6 * C2]$ ,

where  $C2$  is a function of drawdown rate (48-hr = 1.963)

$$\text{So, } \text{DCV} = 1/12 * [189,050 * 0.73 * 0.586 * 1.963] = 13,243.12 \text{ ft}^3$$

So,  $\text{DCV} > \text{Runoff Volume Pre-dev}$

## 4.4. HEC-RAS Result (See Exhibit B and Exhibit C)

### **Basin-A Hydraulic Results**

The hydraulic simulation for Basin A, encompassing a drainage area of 6.94 acres, was performed using a manual approach based on the San Bernardino County (SBC) Hydrology Manual to evaluate flow dynamics and channel behavior. Six cross-sections were strategically placed along the flow path at station points STA 383, STA 332, STA 259, STA 176, STA 94, and STA 54 to ensure detailed representation of the basin's topography. The peak discharge for the 100-year storm event was calculated to be 24.05 cubic feet per second (cfs).

Channel velocities varied across the cross-sections, ranging from 0.76 feet per second at STA 94, the slowest point, to 1.81 feet per second at STA 332, where the velocity was highest. Water surface elevations (W.S. Elevations) exhibited variability as well, with the highest elevation recorded at STA 383, reaching 3724.52 feet. The critical water surface elevation (Crit. W.S.) peaked at STA 259 with a value of 3720.76 feet, while the lowest critical elevation was observed at STA 54 at 3715.92 feet.

The variability in channel velocities and water surface elevations reflects the influence of the basin's topography on flow dynamics. Slower velocities at flatter or wider sections and faster velocities in steeper or narrower areas underscore the importance of site-specific hydraulic considerations. The elevated water surface at STA 383 identifies this section as a critical area for potential flooding during peak flow conditions. Similarly, the high critical water surface elevation at STA 259 highlights its sensitivity to flow changes, making it another point of concern.

These results suggest the need for targeted flood mitigation measures, such as structural reinforcements or flow diversion strategies, to manage peak flow events effectively and reduce the risk of flooding in Basin A's critical areas.

### **Basin-B Hydraulic Results**

The hydraulic simulation for Basin B, encompassing a drainage area of 10 acres, was conducted using a manual approach based on the San Bernardino County (SBC) Hydrology Manual to evaluate flow dynamics and channel behavior. Six cross-sections were strategically identified along the flow path at station points STA 291, STA 246, STA 196, STA 120, STA 71, and STA 28 to ensure accurate representation of the basin's topographic and hydraulic characteristics. The analysis yielded a peak discharge of 33.40 cubic feet per second (cfs) for the 100-year storm event.

Channel velocities ranged from 1.45 feet per second at STA 120, the slowest section, to 2.15 feet per second at STA 28, the fastest section, reflecting variations in flow dynamics influenced by changes in the channel's geometry and slope. The highest water surface elevation (W.S. Elevation) was recorded at STA 291, reaching 3718.23 feet, while the critical water surface elevation (Crit. W.S.) was noted at STA 9, with a value of 3710.65 feet.

The results highlight the variability in flow conditions, with slower velocities observed in flatter or wider sections of the channel and faster velocities in steeper or narrower areas. The elevated water surface at STA 291 suggests a potential area of concern for high water levels during peak flow conditions, while the critical water surface elevation at STA 9 underscores the sensitivity of this location to changes in flow depth and velocity.

These findings indicate the necessity for site-specific flood mitigation measures to address peak flow conditions effectively. Targeted interventions, such as structural reinforcements or slope modifications, may be required to mitigate flooding risks and manage flow dynamics along Basin B's critical points.

## 5. Summary and Conclusion

---

### 5.1. Hydrology

#### **Basin Hydrology**

Each basin was evaluated for the 100-year storm event, with the times of concentration (Tc) and peak flow rates calculated to assess their impact on the site's drainage and flood risk.

#### ***Basin-A:***

Covering 6.94 acres, Basin-A has a flow path of 979 feet and an elevation change of 29.70 feet. The recalculated Tc is 9.50 minutes, producing a peak flow rate of 24.05 cfs. It has a moderate elevation change, indicating swift runoff.

#### ***Basin-B:***

The largest basin, covering 10 acres, with a flow path of 1,000 feet and an elevation difference of 22.80 feet. Its Tc is 10.0 minutes, with a peak flow rate of 33.40 cfs. Larger runoff contribution, emphasizing the need for flood management.

#### **Off-site Hydrology**

The off-site hydrology was divided into two main sections: Off-A (off-site of Basin-A) and Off-B (off-site of Basin-B), and their inflows were analyzed to understand the impact of external runoff on the site.

#### ***Off-A:***

Covers 4.48 acres with a flow path of 593 feet and an elevation change of 14.60 feet. Its Tc is 8.0 minutes, and its peak flow rate is 17.54 cfs, which flows into Basin-A of project-site.

#### ***Off-B:***

Covers 7.89 acres with a flow path of 695 feet and an elevation change of 19.90 feet. Its Tc is 8.30 minutes, with a peak flow rate of 30.09 cfs, contributing significantly to Basin-B.

### **On-site Hydrology**

For on-site hydrology, the contributions from both internal and external runoff were analyzed by subtracting off-site inflows from the total discharge of each basin.

#### ***Basin-A:***

The total discharge was calculated as 33.40 cfs, with 17.54 cfs coming from Off-A, resulting in an on-site discharge of 6.51 cfs.

#### ***Basin-B:***

The total discharge was 33.40 cfs, with 30.09 cfs from Off-B, leaving an on-site discharge of 3.30 cfs.

## **5.2. Hydraulics**

### **On-site Volume Mitigation**

Based on the San Bernardino County Hydrology Manual, the design runoff for the on-site portion is calculated using the Curve Number (CN) method. For this site, the 2-year, 24-hour rainfall depth is 1.53 inches, and the 2-year, 1-hour rainfall depth is 0.474 inches, and the CN is 56. The soil storage capacity is 7.86 inches, with an initial abstraction of 1.57 inches. These values result in a calculated runoff volume of approximately 0.0001 **acre-feet (3.46 cubic feet)** under existing conditions.

### **Design Capture Volume (DCV)**

According to the Phase 2 MS4 Permit and the Mojave River Watershed Technical Guidance for Water Quality Management Plans, the Design Capture Volume (DCV) was calculated for a site area of 189,050 square feet, assuming 90% impervious surface. Using a 24-hour, 85th percentile storm event, the DCV is **13,243.12 cubic feet** for Industrial land use.

### **HEC-RAS Results**

#### ***Basin-A***

The hydraulic simulation for Basin A, with a drainage area of 6.94 acres, indicated a peak discharge of 24.05 cfs for the 100-year storm event. Channel velocities ranged from 0.76 ft/s at STA 94 to 1.81 ft/s at STA 332. Water surface elevations varied from 3716.01 feet at STA 54 to 3724.52 feet at STA 383, with the highest critical water surface elevation at STA 259 at 3720.76 feet. These results highlight critical areas like STA 383 and STA 259 that may be vulnerable to flooding during peak flow events, suggesting the need for flood mitigation measures.

## **Basin-B**

For Basin B, covering 10 acres, the peak discharge was 33.40 cfs during the 100-year storm event. Channel velocities ranged from 1.45 ft/s at STA 120 to 2.15 ft/s at STA 28. Water surface elevations ranged from 3710.65 feet at STA 9 to 3718.23 feet at STA 291. The critical water surface elevation at STA 9 was 3710.65 feet. Similar to Basin A, critical areas like STA 291 and STA 9 require attention for potential flooding, indicating the need for targeted flood mitigation measures.

The hydrologic and hydraulic analysis of the site reveals crucial insights for effective flood risk management and runoff control. Both **Basin-A** and **Basin-B** are significant contributors to runoff, with Basin-B being the largest in terms of flow rate. The analysis indicates that both on-site and off-site contributions must be considered in flood mitigation strategies, especially as off-site inflows, such as those from Off-A and Off-B, also significantly affect the peak flows in the basins. The **on-site volume mitigation** required, calculated to be 4.34 acre-feet, must be addressed with the recommended **Design Capture Volume (DCV)** of 13,243.12 cubic feet to ensure efficient runoff management and avoid potential flooding.

Hydraulic simulations suggest that both basins have sections with critical water surface elevations that could lead to flooding during peak storm events. Specifically, **Basin-A** shows elevated water levels at STA 383 and STA 259, while **Basin-B** shows similar risks at STA 291. These results highlight the need for targeted flood mitigation measures such as structural reinforcements, slope modifications, or flow diversion to manage peak flow events and protect the site from potential flooding. The findings emphasize the importance of an integrated approach to hydrology and hydraulics in designing a sustainable drainage system for the site.

## 6. Recommendation

---

Based on the hydrology and hydraulic conclusions, the results highlight specific areas of concern and necessary mitigation strategies to address both on-site and off-site stormwater challenges.

To effectively manage stormwater runoff and reduce the flood risk in the area, it is recommended to install on-site stormwater mitigation measures, such as detention or retention basins, to capture and store runoff water, ensuring it meets the required Design Capture Volume (DCV). Upgrading the drainage systems, particularly in critical areas, will be essential to accommodate higher peak flow rates and prevent potential flooding. In addition, implementing green infrastructure solutions like permeable pavements, swales, and green roofs can help reduce runoff and promote water infiltration. Regular hydrological monitoring should also be set up to track water levels, flow rates, and stormwater behavior, offering early flood warnings and improving future resilience.

The implications of these measures are significant. Without effective stormwater management, the site could experience considerable flooding, especially in areas with high peak flow rates. Addressing these concerns through both on-site and off-site solutions is vital to prevent future flood damage. Additionally, implementing green infrastructure will not only help reduce runoff but also contribute to long-term environmental sustainability. Finally, these measures are crucial for compliance with local regulations and ensuring public safety, preventing potential legal or financial issues down the line.

# 7. References

---

County of San Bernardino, Hydrology Manual

Mojave River Watershed Technical Guidance Document for Water Quality Management Plans.

(2016).

US Army Corps of Engineers – Hydrologic Engineering Center, HECHMS User's Manual

US Army Corps of Engineers – Hydrologic Engineering Center, HECRAS User's Manual

US Department of Transportation - Federal Highway Administration, HY-8 Culvert Analysis Program

# PRELIMINARY GRADING PLAN

SUN MESA ROAD, YUCCA VALLEY, CA

APN: 0597-111-67

### LEGAL DESCRIPTION:

TR 8749, MB 120/50-64 SEC. 13, T1N, R5E, S.B.B.&M.  
APN: 0597-111-67

### BASIS OF BEARING:

THE SOUTHWEST 1/4 OF SECTION 13 PER TRACT 8749, MB 120/50-64 SAID BEARING BEING N00°00'08"E

### BENCHMARK:

USGS BM 705 24  
ELEVATION = 3718.55 FEET, NAVD 88

### OWNER/DEVELOPER

ROB BILLINGS  
5024 WALLABY STREET  
YUCCA VALLEY, CA 92284  
760-686-4171  
BILLINGSTRANSFER@YAHOO.COM

### TOPOGRAPHY:

PREPARED BY:  
LSAP CONSULTANTS LLC.  
ADDRESS: 14997 MCGARGER RD  
DESERT HOT SPRINGS, CA 92240  
(760) 288-2232  
SURVEY@LSAPCONSULTANTS.COM  
DATE OF SURVEY JAN 2022

### YUCCA VALLEY

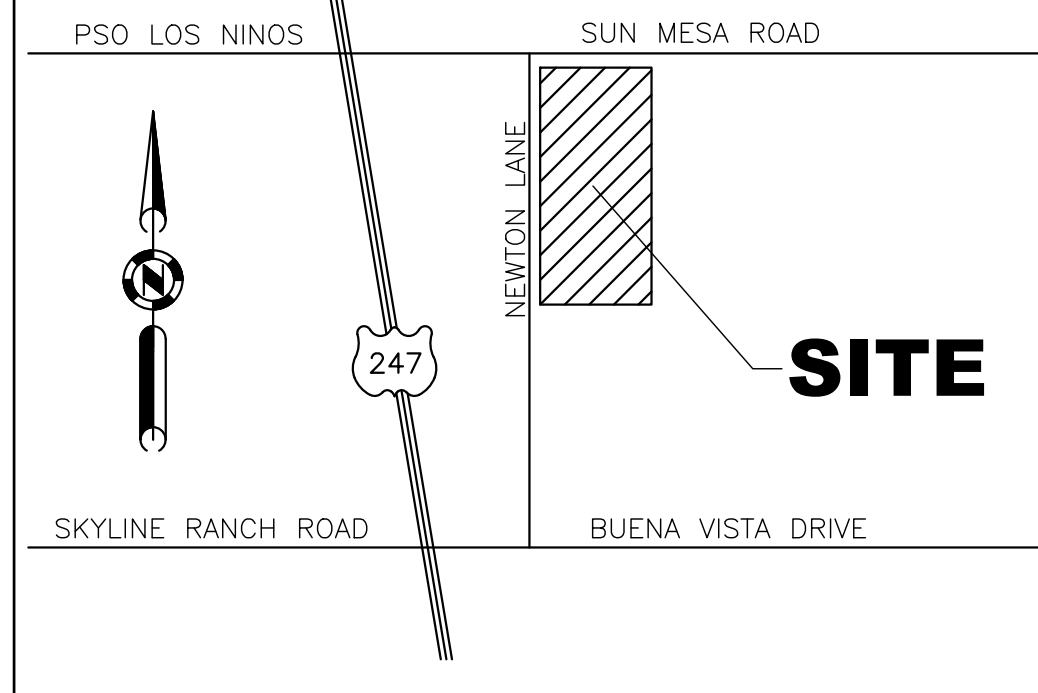

### VICINITY MAP

### LEGEND:

—	CENTERLINE	EP	EDGE OF PAVEMENT
—	PROPERTY LINE	FF	FINISHED FLOOR
—	WATER LINE	FG	FINISHED GROUND
—	SEWER LINE	FL	FLOW LINE
—	ELECTRIC LINE	FS	FINISHED SURFACE
—	GAS LINE	GB	GRADE BREAK
—	EXIST. CHAIN LINK FENCE	HP	HIGH POINT
—	EXIST. WOOD FENCE	INV	INVERT ELEVATION
—	EXIST. BLOCK WALL	PAD	PAD ELEVATION
—	EXIST. CONTOUR LINE	RET.	RETAINING WALL
—	EXIST. SPOT ELEVATION	TC	TOP OF CURB
—	EXIST. FIRE HYDRANT	TG	TOP OF GRATE
—	EXIST. POWER POLE		
—	EXIST. SEWER MANHOLE		
—	EXIST. STORM DRAIN MANHOLE		
—	EXIST. WATER METER		
—	EXIST. WATER VALVE		
—	EXIST. TREE		

### CONSTRUCTION NOTE:

- 1 PROPOSED AC PAVEMENT
- 2 PROPOSED 6" CURB AND GUTTER
- 3 PROPOSED DRIVEWAY APPROACH
- 4 PROPOSED CONC. PAVEMENT
- 5 PROPOSED CONC. RIBBON GUTTER
- 6 PROPOSED 36"x36" CATCH BASIN WITH TRAFFIC RATED STEEL GRATE
- 7 PROPOSED 18" RCP
- 8 PROPOSED 1" SERVICE METER
- 9 PROPOSED SEPTIC TANK
- 10 PROPOSED LEACH FIELD
- 11 TRASH ENCLOSURE
- 12 PROPOSED RETAINING WALL

### EARTHWORK VOLUMES:

TOTAL CUT - 4970 CY  
TOTAL FILL - 4485 CY  
\* SEE EARTHWORK EXHIBIT FOR INFORMATION ON CUT-FILL BY LOCATION MAP.

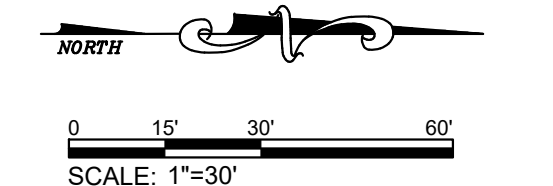
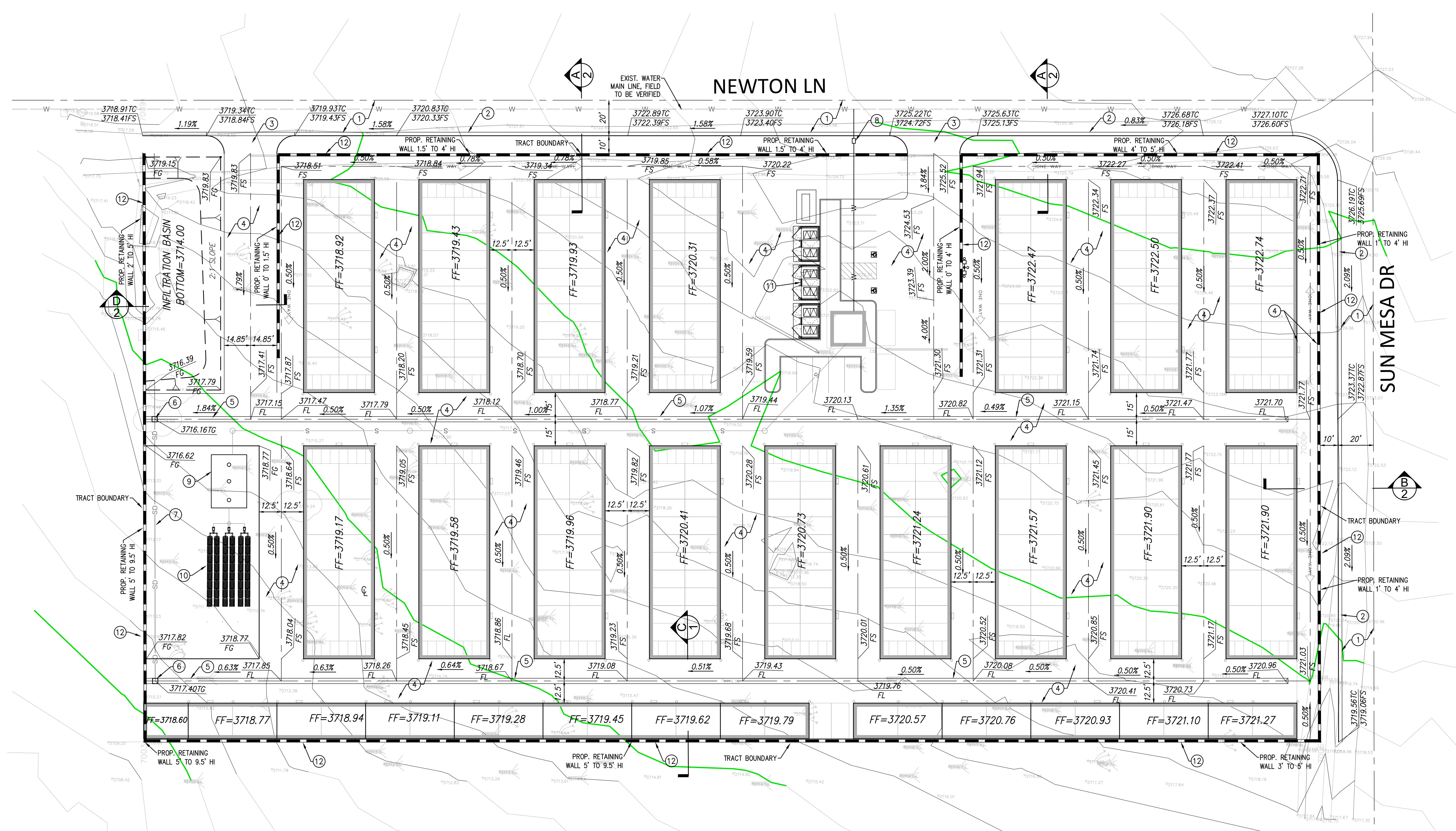

SHEET 1 OF 2



DRP ENTERPRISES LLC  
Daniel Patneude  
MAILING ADDRESS:  
PO Box 4428  
Palm Springs, CA 92263  
206-734-7765  
DPATNEUDE@DRPENTERPRISELIC.CA  
WWW.DRPENTERPRISELIC.CA  
Joanne C. Singer RCE 26900  
760-625-7426

# PRELIMINARY GRADING PLAN

SUN MESA ROAD, YUCCA VALLEY, CA

APN: 0597-111-67

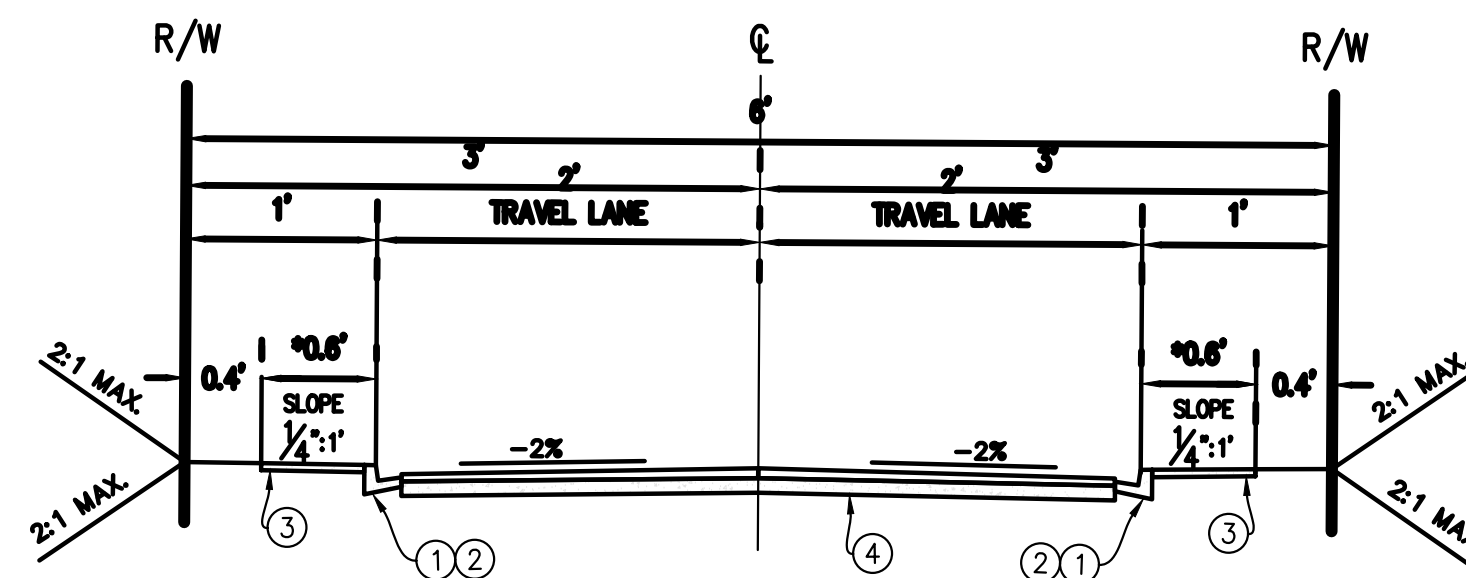

TYPICAL SECTION  
LEVEL

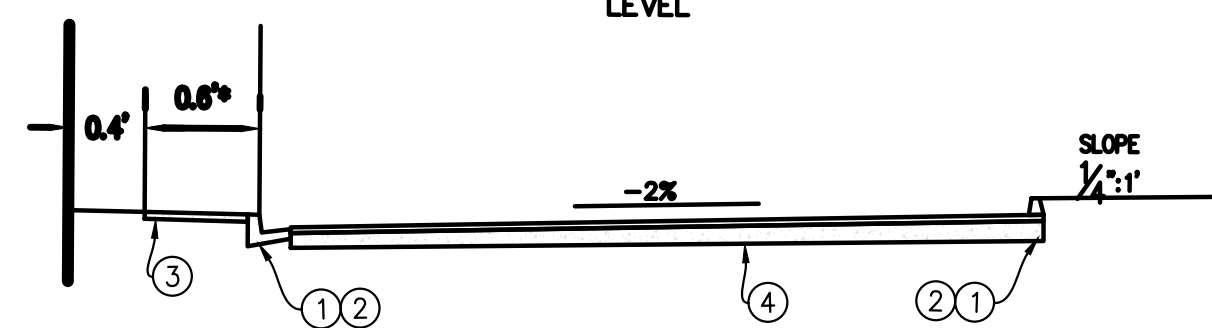

TYPICAL SECTION  
TILT

**NOTES:**

- ① CURB AND GUTTER STD. DWG. NO. 200
- ② A.C. DIKE PER STD DWG. 202 \*\*
- ③ SIDEWALK PER STD. DWG. NO. 220
- ④ PAVEMENT SECTION PER STD. DWG. NO. 240

\*SIDEWALK REQUIREMENT PER DEVELOPMENT CODE  
 \*\*LIMITED USE, SHORT TERM IMPROVEMENT PROJECTS

**LOCAL STREET SECTION SUN MESA-NEWTON LN**  
 NOT TO SCALE

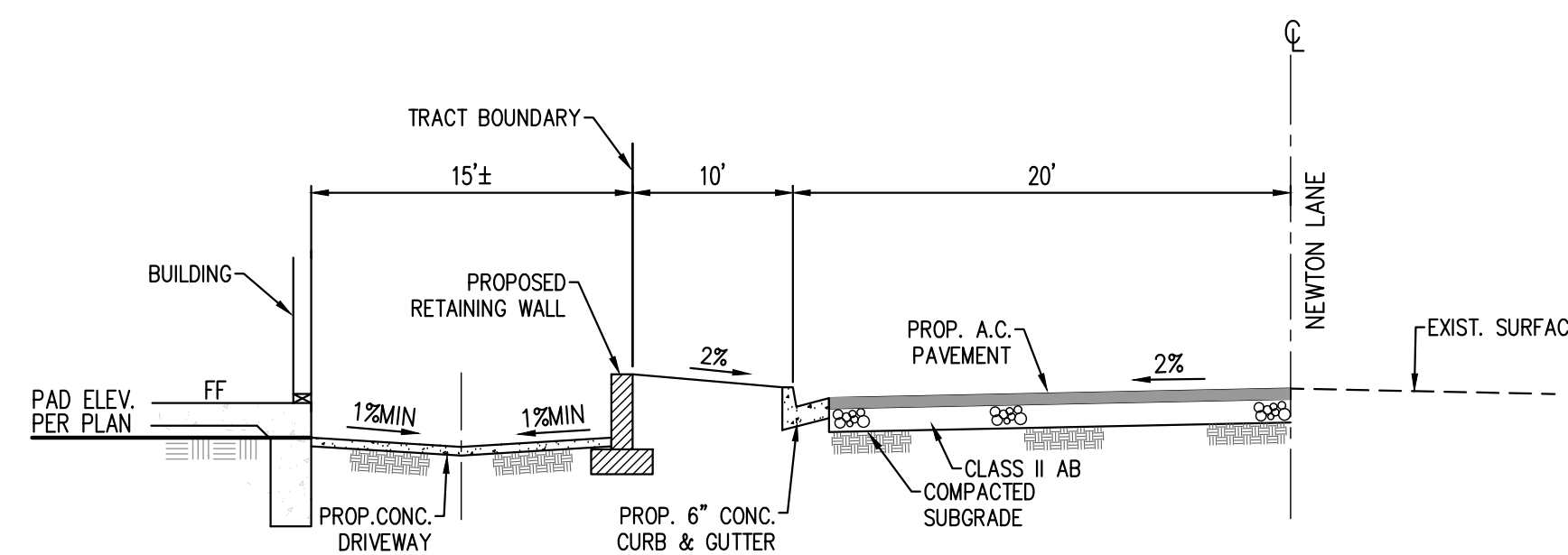

SECTION 'A' NEWTON LANE  
 NTS

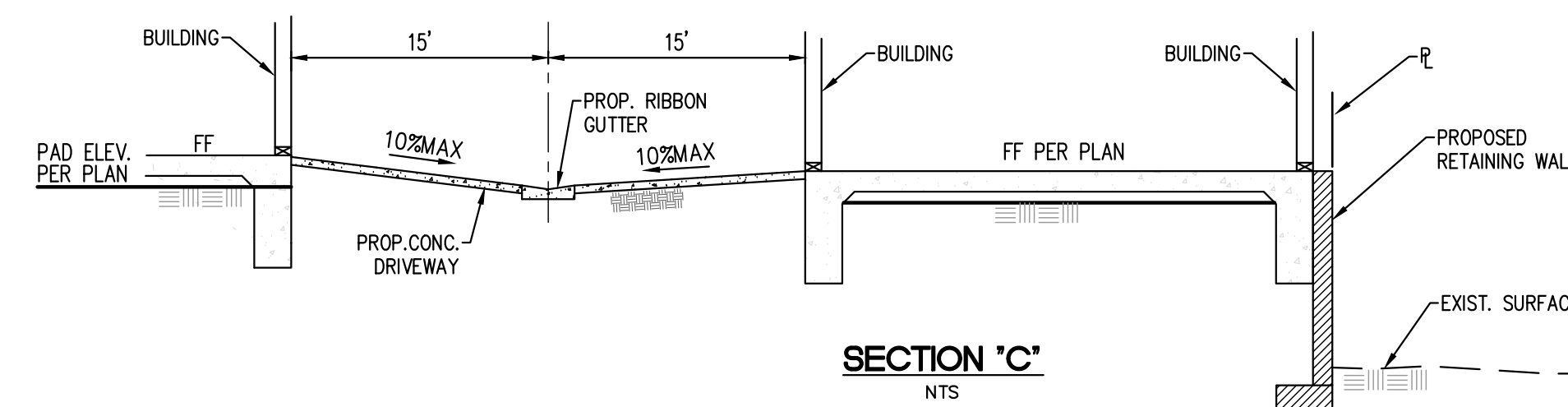

SECTION 'C'  
 NTS

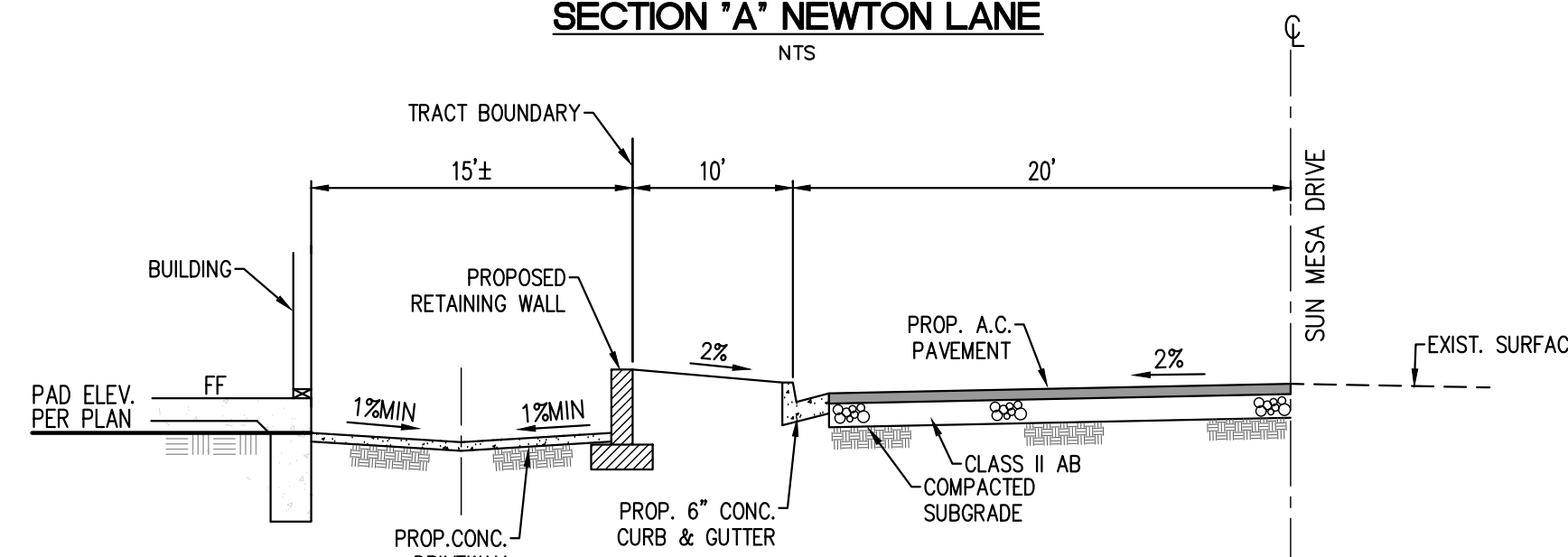

SECTION 'B' SUN MESA DRIVE  
 NTS

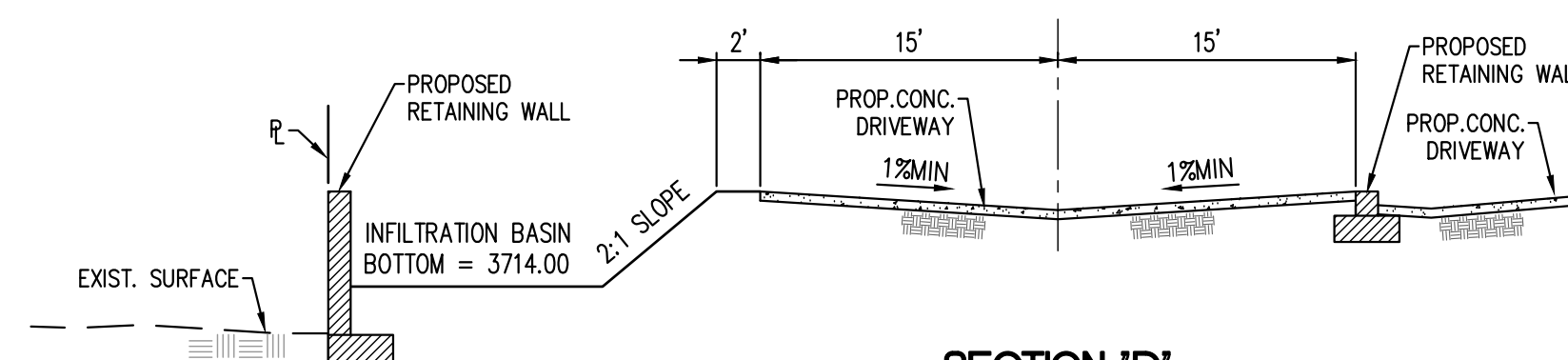

SECTION 'D'  
 NTS

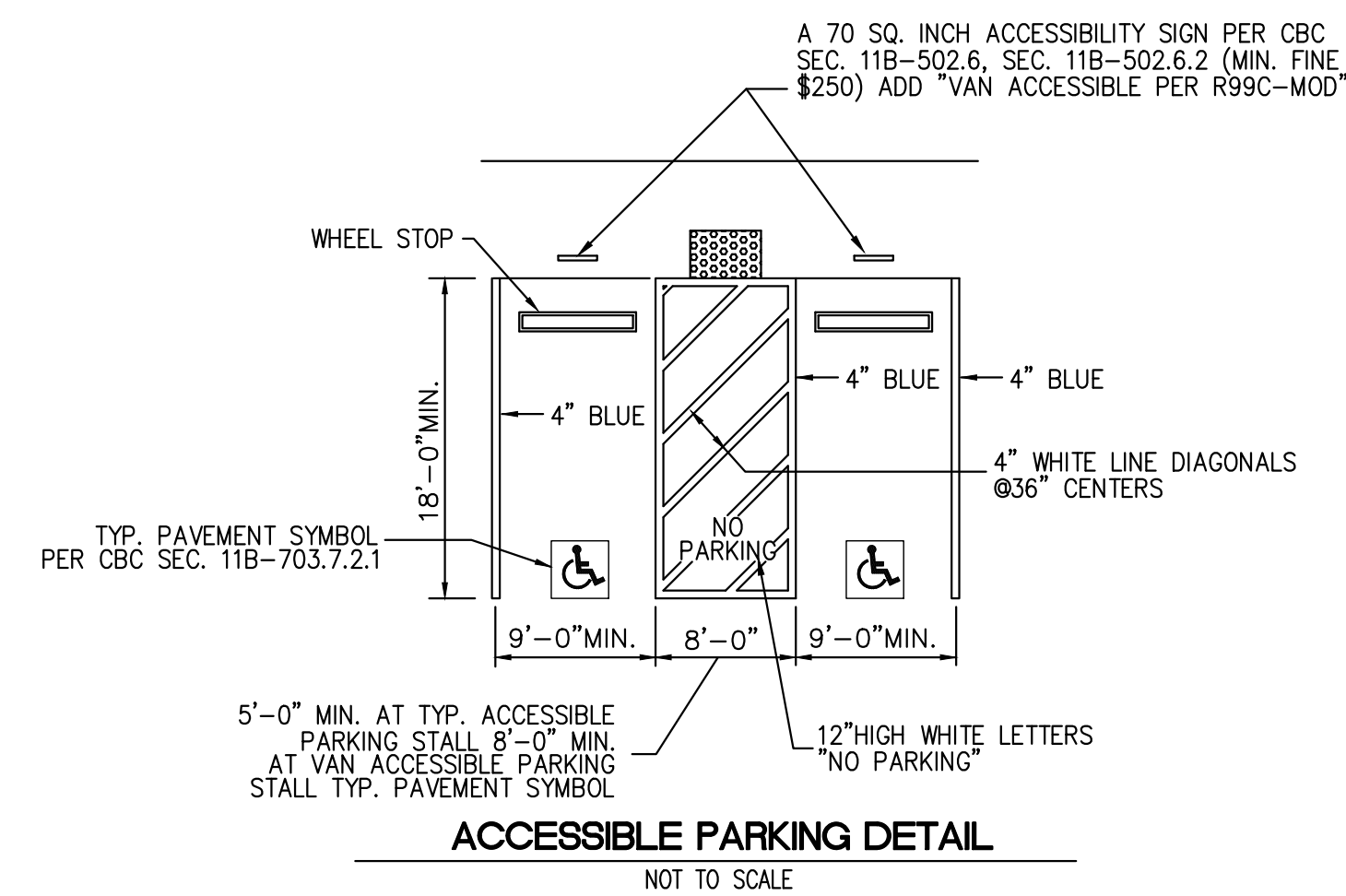

ACCESSIBLE PARKING DETAIL  
 NOT TO SCALE

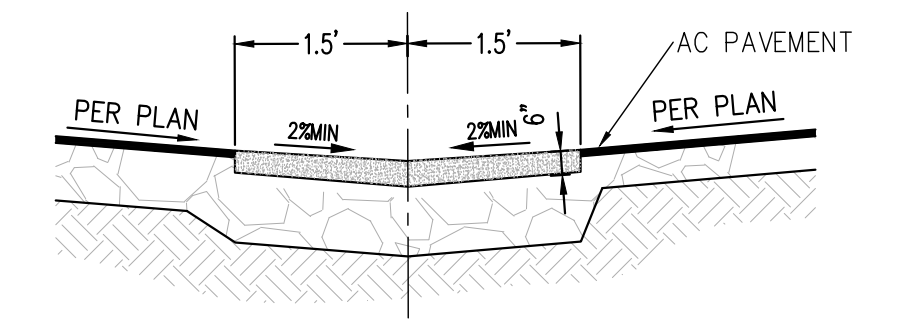

RIBBON GUTTER DETAIL  
 N.T.S.



DRP ENTERPRISES LLC  
 Daniel Patneude  
 MAILING ADDRESS:  
 PO Box 4428  
 Palm Springs, CA 92263  
 206-734-7765  
 DPATNEUDE@DRPENTERPRISESLLC.ORG  
 WWW.DRPENTERPRISESLLC.ORG  
 Joanne C. Singer RCE 26900  
 760-625-7426



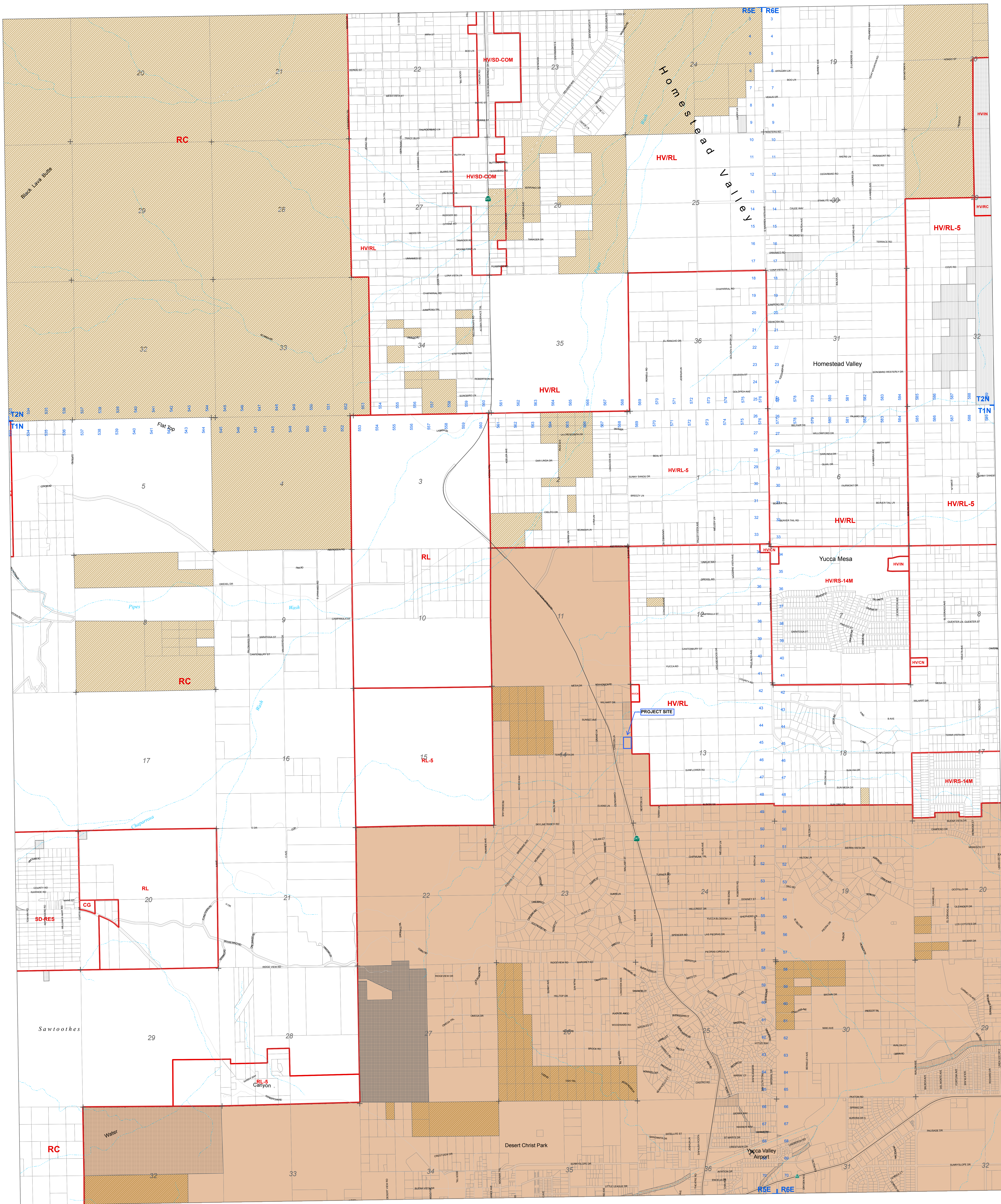

See F120 A

See F122 A

San Bernardino County Land Use Plan  
GENERAL PLAN  
Land Use Zoning Districts

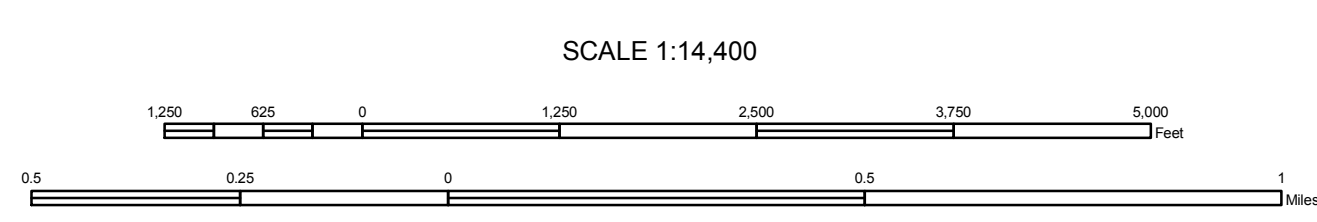

Land Use Zoning Districts

- |                              |                           |                            |
|------------------------------|---------------------------|----------------------------|
| AG – Agriculture             | CS – Service Commercial   | RC – Resource Conservation |
| CG – General Commercial      | FW – Floodway             | RL – Rural Living          |
| CH – Highway Commercial      | IC – Community Industrial | RM – Multiple Residential  |
| CN – Neighborhood Commercial | IN – Institutional        | RS – Single Residential    |
| CO – Office Commercial       | IR – Regional Industrial  | SD – Special Development   |
| CR – Rural Commercial        | OS – Open Space           | SP – Specific Plan         |

County designated Land Use Zoning Districts do not apply to Federal or State owned property.

Legend

- |                 |                          |                        |
|-----------------|--------------------------|------------------------|
| BLM             | State                    | Private Unincorporated |
| National Park   | Indian Land              | RDA                    |
| National Forest | Other Federal Government |                        |
| Military        | County                   |                        |

Jurisdictional Control data is for informational purposes only and is not part of the General Plan Land Use Zoning. The depiction of the various land ownership categories is the best available information but cannot be guaranteed accurate. For current land ownership information please contact the San Bernardino County Assessor's Office.

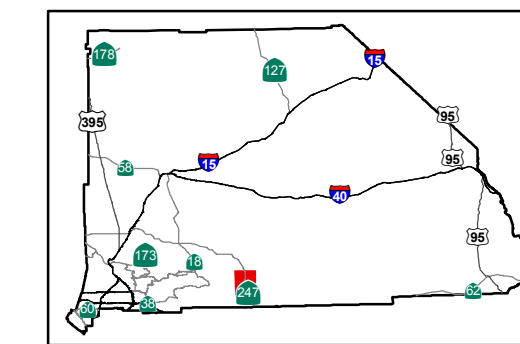

# FLOOD PLAIN SAFETY DISTRICTS

2014

## OFFICIAL ZONING DISTRICT MAP

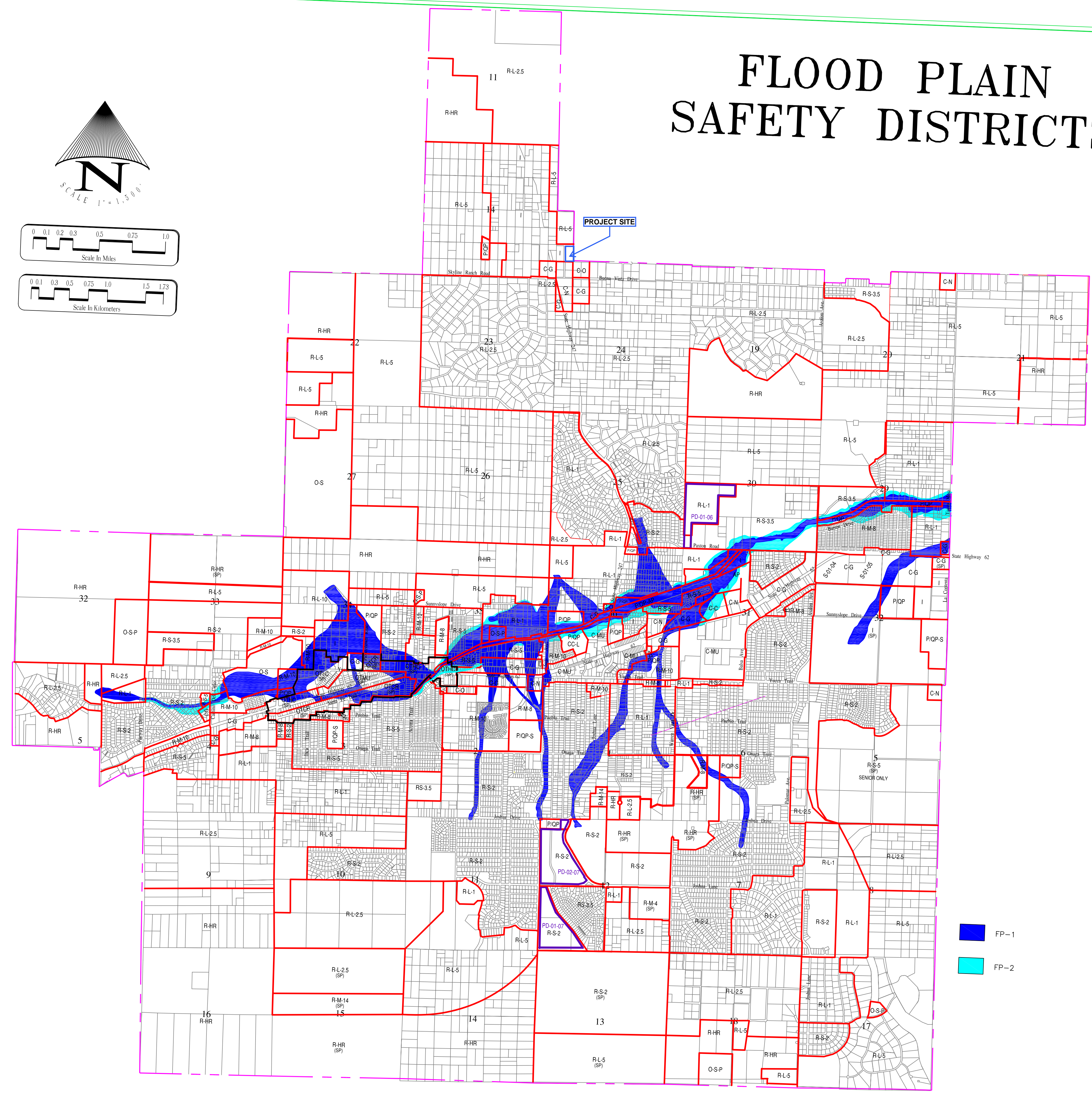
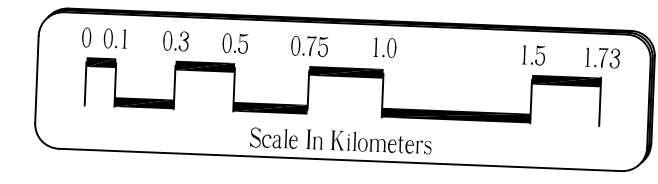
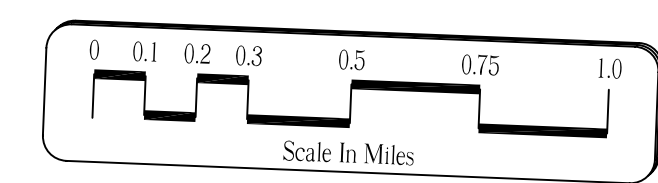

### LEGEND

- R-HR HILLSIDE RESERVE (1 du / 20 ac.)
- R-L RURAL LIVING (1 du / 1, 2.5, 5, 10, 20 ac.)
- R-S RESIDENTIAL, SINGLE FAMILY (0-2, 0-3.5, 0-5 du/ac.)
- R-M RESIDENTIAL, MULTI-FAMILY (1-10, 0-14 du/ac.)
- C-MU MIXED USE COMMERCIAL (Varies)
- C-N NEIGHBORHOOD COMMERCIAL
- C-G GENERAL COMMERCIAL
- C-C COMMUNITY COMMERCIAL
- C-O OFFICE COMMERCIAL
- I INDUSTRIAL
- P/QP PUBLIC/QUASI PUBLIC (SEE SYMBOLS)
- O-S OPEN SPACE (SEE SYMBOLS)
- (SP) SPECIFIC PLAN

### OLD TOWN LAND USE

- OTHC OLD TOWN HIGHWAY COMMERCIAL
- OTIC OLD TOWN INDUSTRIAL/COMMERCIAL
- OTMU OLD TOWN MIXED USE
- OTCR OLD TOWN COMMERCIAL/RESIDENTIAL

### SYMBOLS

#### PUBLIC/QUASI PUBLIC

- AP AIRPORT
- CC CIVIC CENTER
- FS FIRE STATION
- PS POLICE STATION
- H HOSPITAL
- S SCHOOL
- L LIBRARY
- FW FLOODWAY

#### OPEN SPACE

- O-S-P PARK

#### LAND USE PLANS

- SP SPECIFIC PLAN
- PD PLAN DEVELOPMENT

- FP-1
- FP-2



## Town of YUCCA VALLEY

TOWN COUNCIL MEETING  
DECEMBER 16, 2014

# EXISTING CONDITION HYDROLOGY MAP

APN: 059711167  
 SUN MESA ROAD  
 YUCCA VALLEY, CA 92284



VICINITY MAP  
 N.T.S.

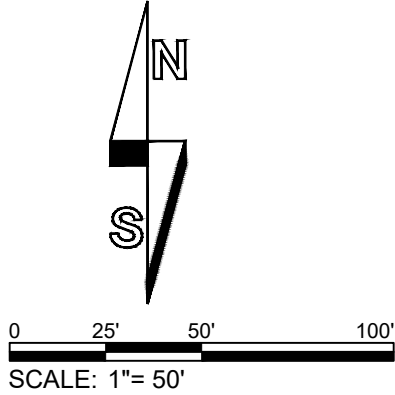

**LEGEND**

	DRAINAGE BOUNDARY
	FLOW PATH LENGTH
	FLOW DIRECTION

OFF-A  
 100-YEAR PEAK  
 FLOW=17.54 CFS

BASIN-A ON-SITE  
 100-YEAR PEAK  
 FLOW=6.51 CFS

**PROJECT SITE  
 AREA, A=4.34 ACRES**

BASIN-A  
 100-YEAR PEAK FLOW  
 =24.05 CFS

OFF-B  
 100-YEAR PEAK  
 FLOW =30.09 CFS

BASIN-B ON-SITE  
 100-YEAR PEAK FLOW  
 =3.30 CFS

BASIN-B  
 100-YEAR PEAK FLOW  
 =33.40 CFS

**PREPARE BY:**

DRP ENTERPRISES LLC  
 Daniel Patneude  
 MAILING ADDRESS:  
 PO Box 4428  
 Palm Springs, CA 92263  
 206-734-7765  
 Joanne C. Singer RCE 26900  
 760-625-7426



# BASIN - A ANALYSIS

APN: 059711167  
SUN MESA ROAD,  
YUCCA VALLEY, CA 92284



VICINITY MAP  
N.T.S.

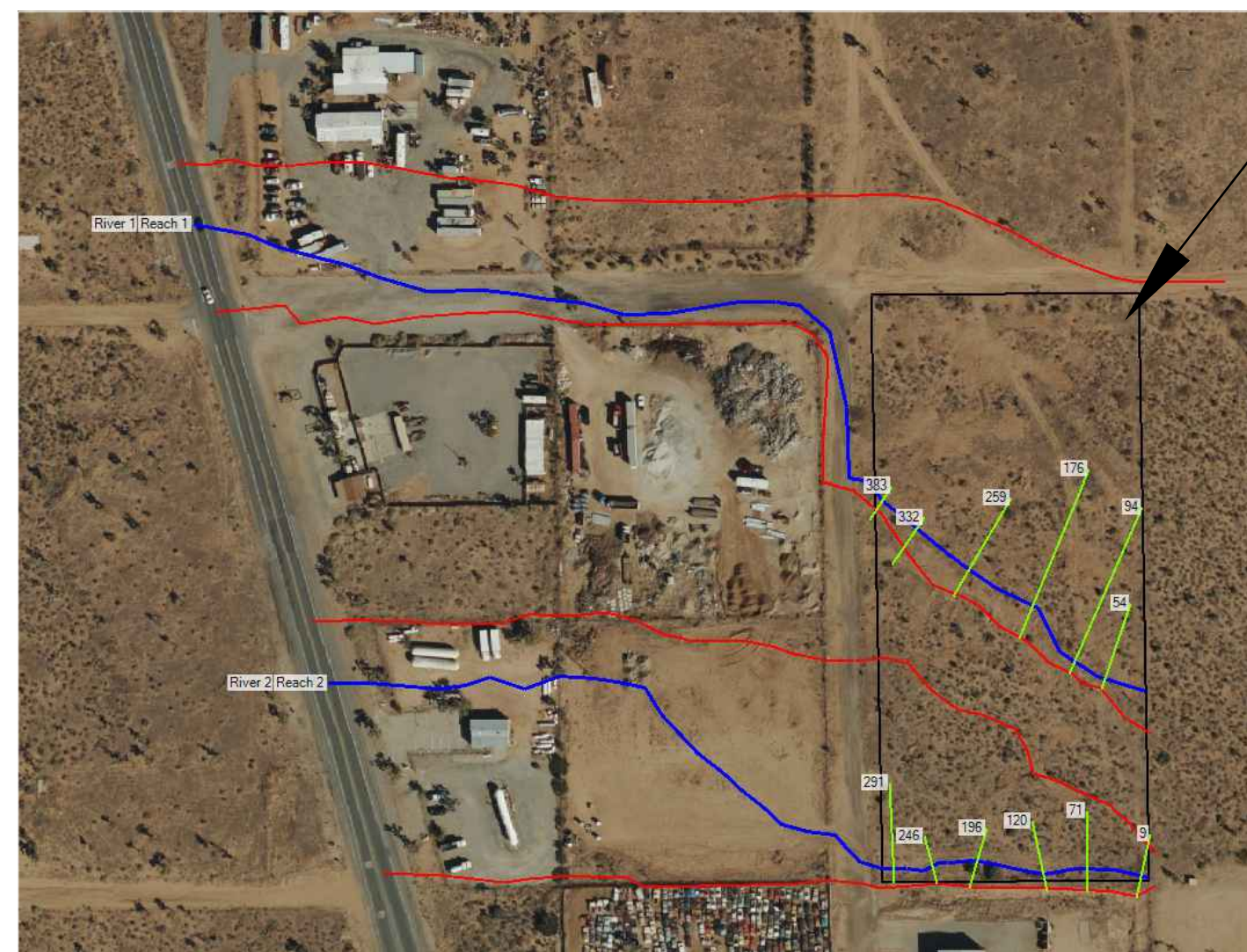

PROJECT SITE

APPLICANT / OWNER / DEVELOPER

ROBERT BILLINGS  
SUN MESA ROAD  
YUCCA VALLEY, CA 92284

X-SECTION: 54

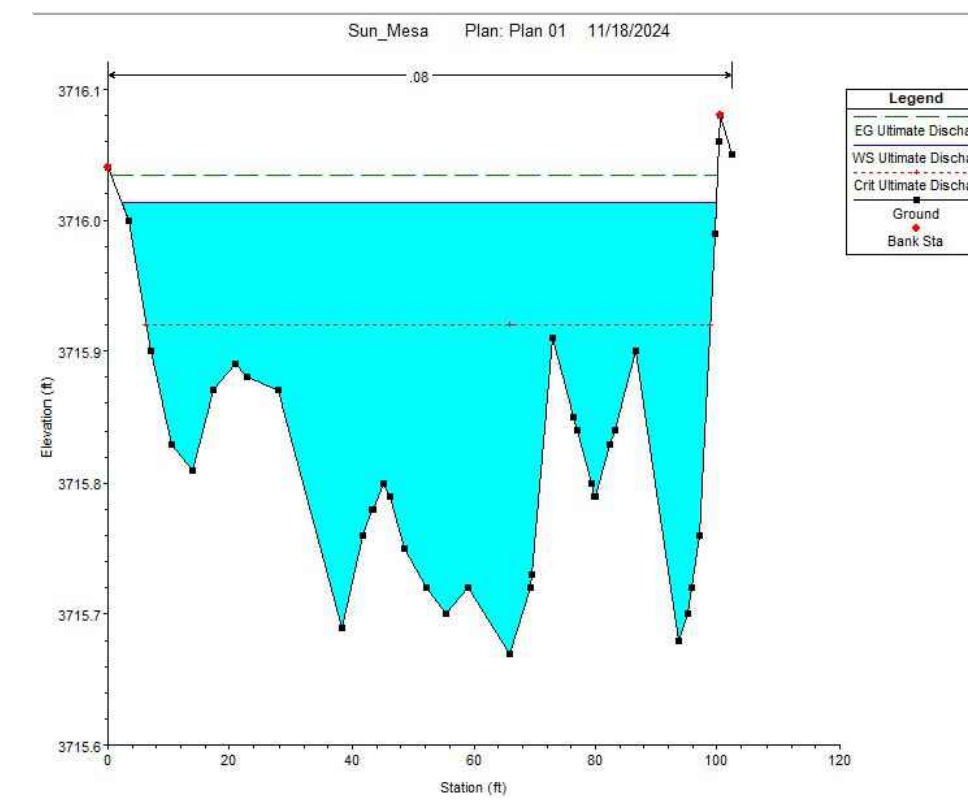

X-SECTION: 94

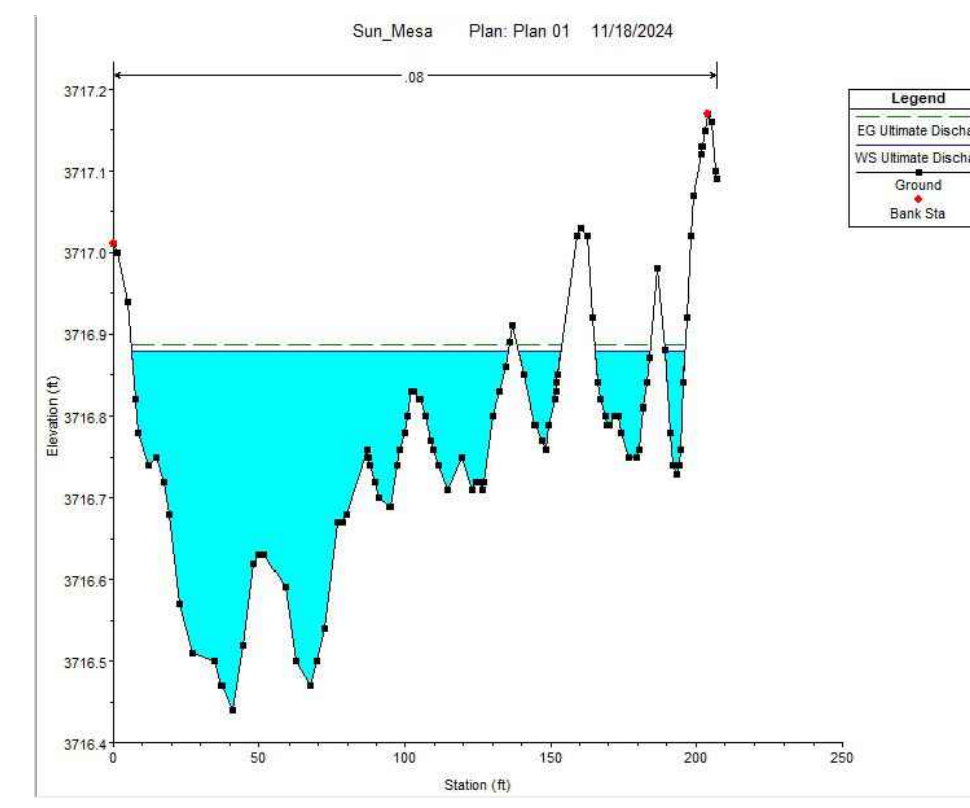

X-SECTION: 176

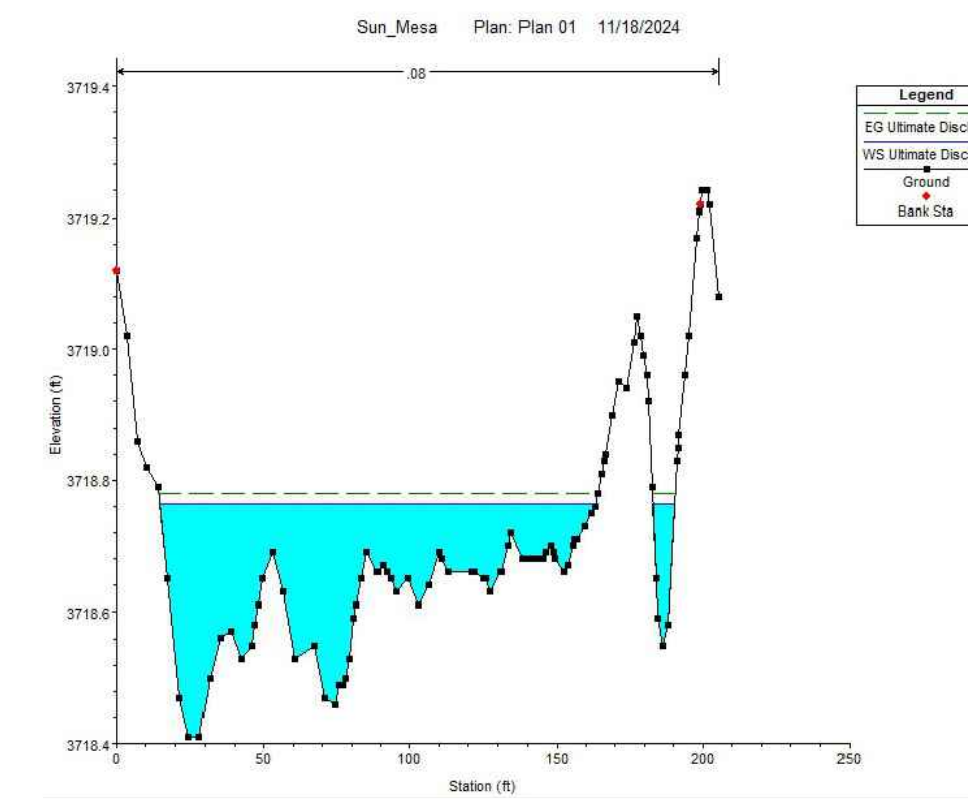

X-SECTION: 259

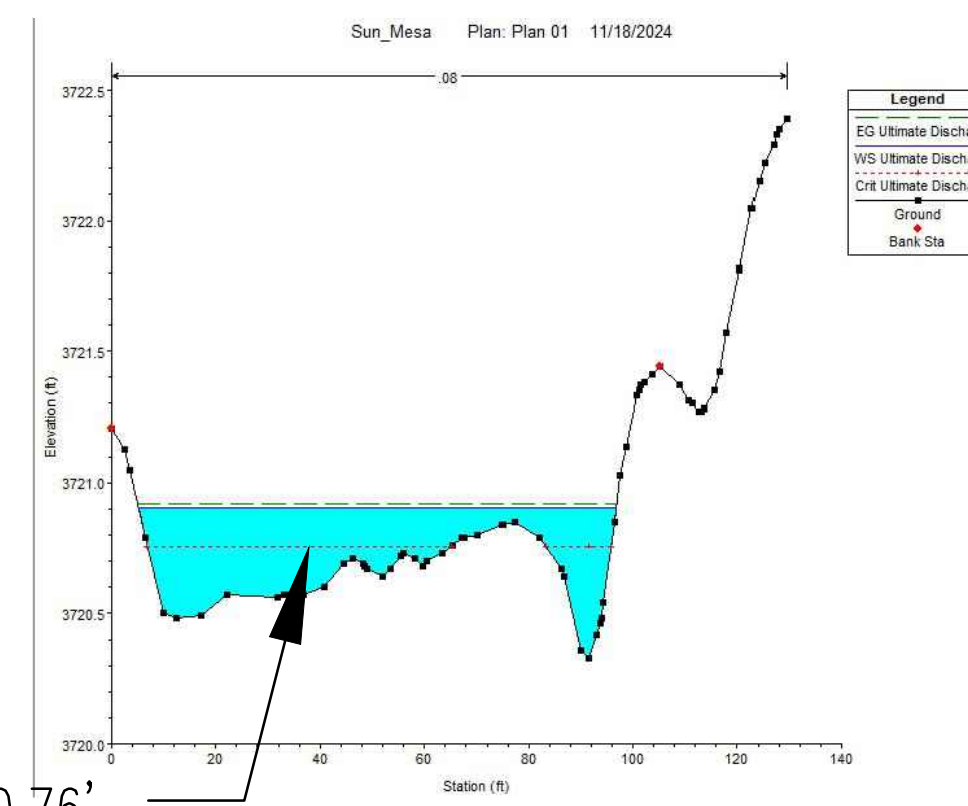

X-SECTION: 332

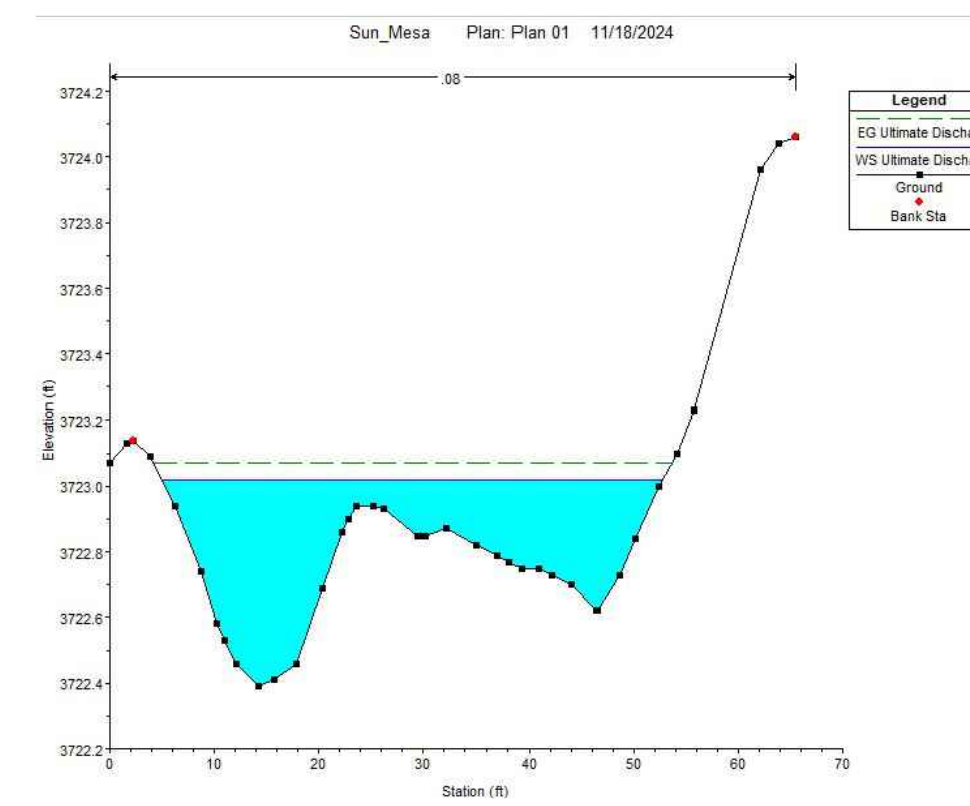

X-SECTION: 383

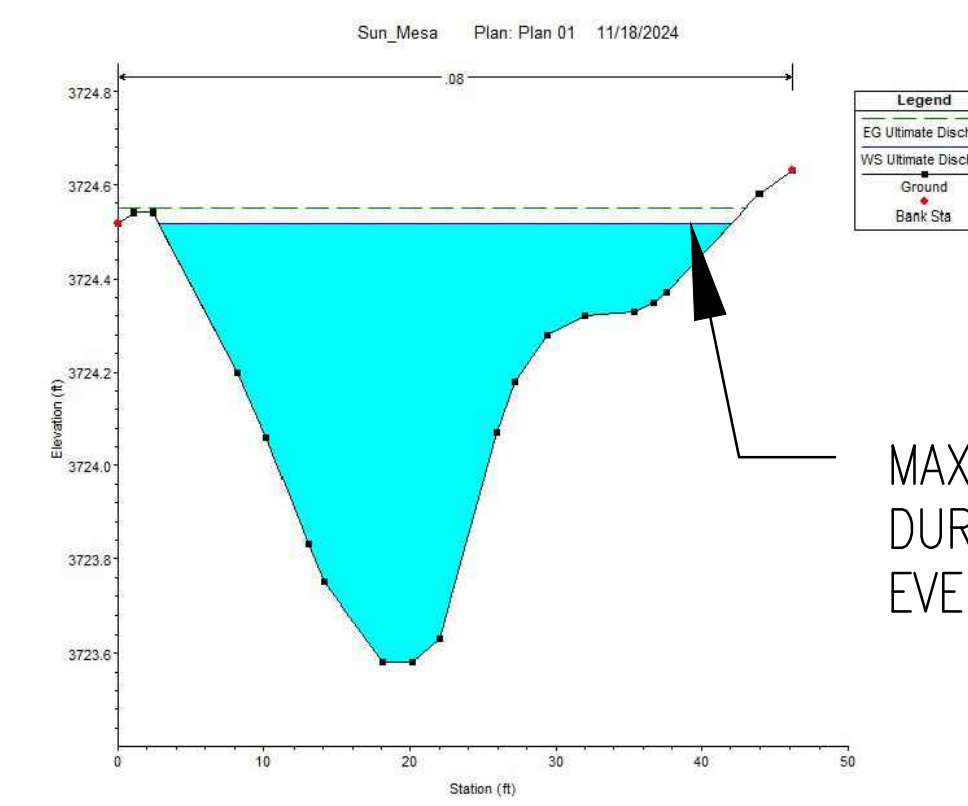

MAX WSE= 3724.52'  
DURING 100-YR STORM  
EVENT

CRIT. WATER SURFACE=3720.76'  
DURING 100-YR STORM EVENT

## HEC-RAS SUMMARY RESULTS

HEC-RAS Plan: Plan 01 River: River 1 Reach: Reach 1 Profile: Ultimate Dischar												
Reach	River Sta	Profile	Q Total (cfs)	Min Ch El (ft)	W.S. Elev (ft)	Crit W.S. (ft)	E.G. Elev (ft)	E.G. Slope (ft/ft)	Vel Chnl (ft/s)	Flow Area (sq ft)	Top Width (ft)	Froude # Chl
Reach 1	383	Ultimate Dischar	24.05	3723.58	3724.52		3724.55	0.018649	1.44	16.75	39.28	0.39
Reach 1	332	Ultimate Dischar	24.05	3722.39	3723.02		3723.07	0.052599	1.81	13.26	47.70	0.61
Reach 1	259	Ultimate Dischar	24.05	3720.33	3720.90	3720.76	3720.92	0.018430	1.02	23.59	91.67	0.35
Reach 1	176	Ultimate Dischar	24.05	3718.41	3718.76		3718.78	0.038250	1.03	23.43	155.99	0.47
Reach 1	94	Ultimate Dischar	24.05	3716.44	3716.88		3716.89	0.015453	0.76	31.78	169.36	0.31
Reach 1	54	Ultimate Dischar	24.05	3715.67	3716.01	3715.92	3716.03	0.030327	1.15	20.83	97.63	0.44

### PREPARE BY:

DRP ENTERPRISES LLC  
Daniel Patneude  
MAILING ADDRESS:  
PO Box 4428  
Palm Springs, CA 92263  
206-734-7765  
Joanne C. Singer RCE 26900  
760-625-7426



# BASIN - B ANALYSIS

APN: 058920122  
63926 Rocking Chair Rd.,  
Joshua Tree, CA 92252



**VICINITY MAP**  
N.T.S.

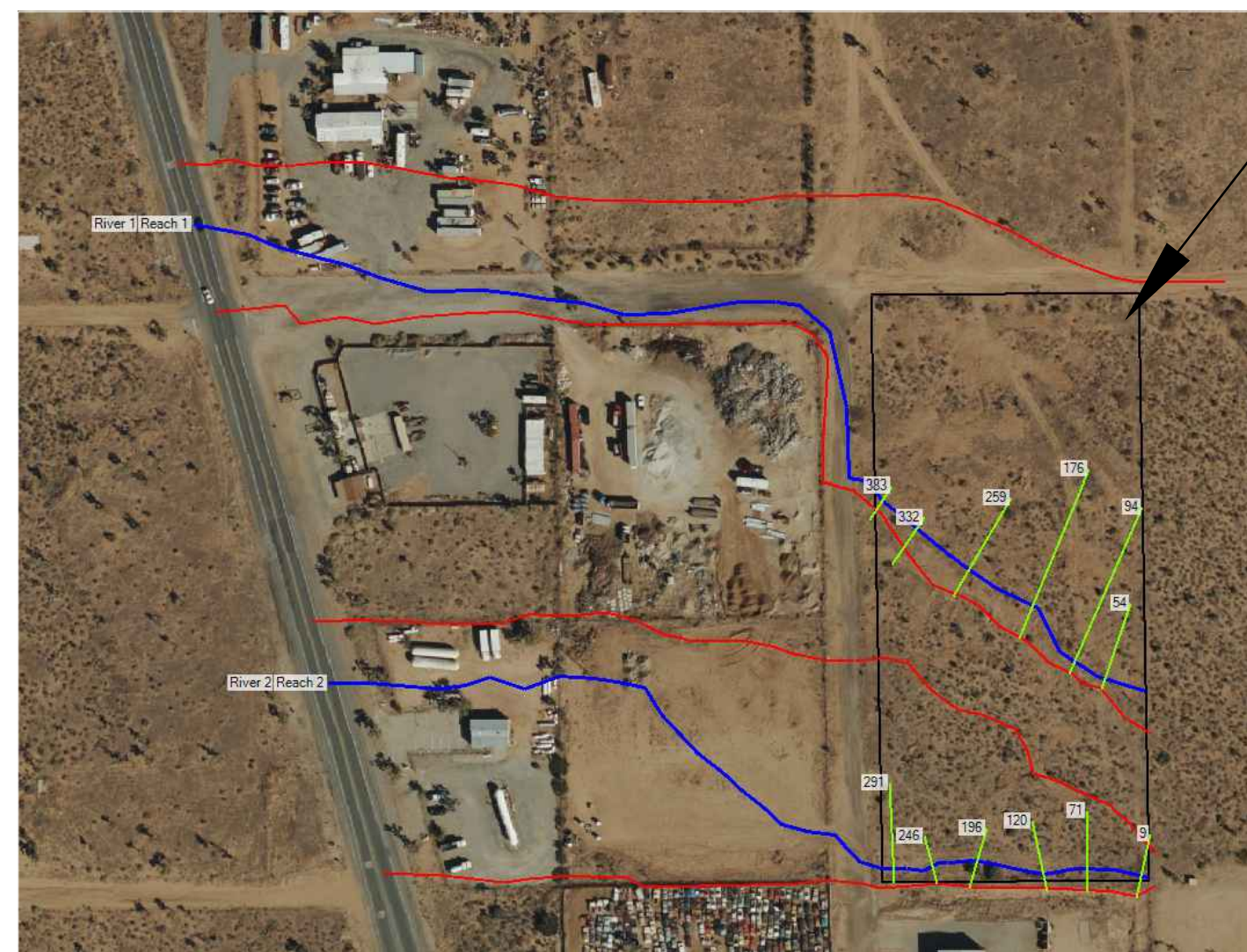

PROJECT SITE

APPLICANT / OWNER / DEVELOPER  
ROBERT BILLINGS  
SUN MESA ROAD  
YUCCA VALLEY, CA 92284

## X-SECTION: 9

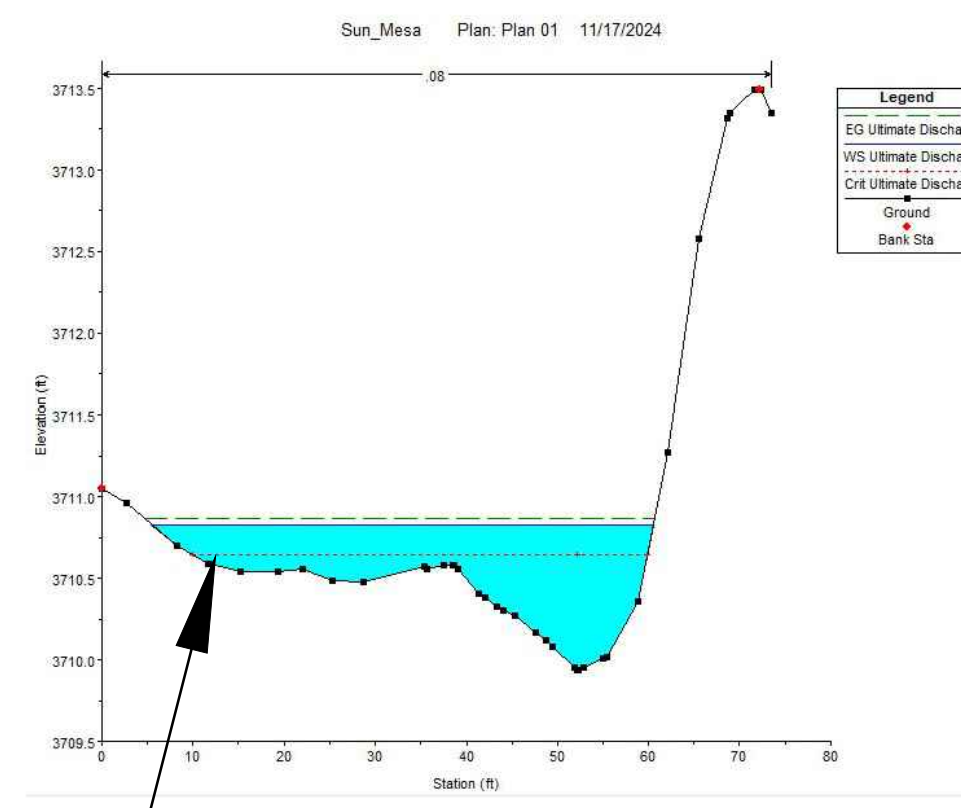

CRIT. WATER SURFACE=3710.65'  
DURING 100-YR STORM EVENT

## X-SECTION: 71

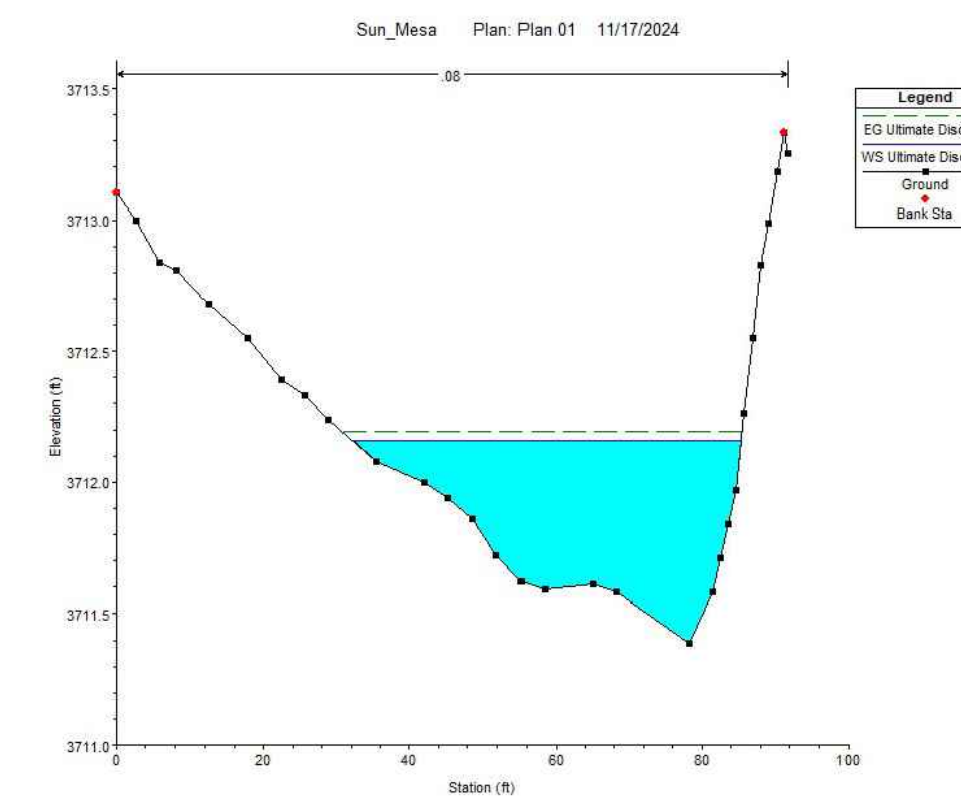

## X-SECTION: 120

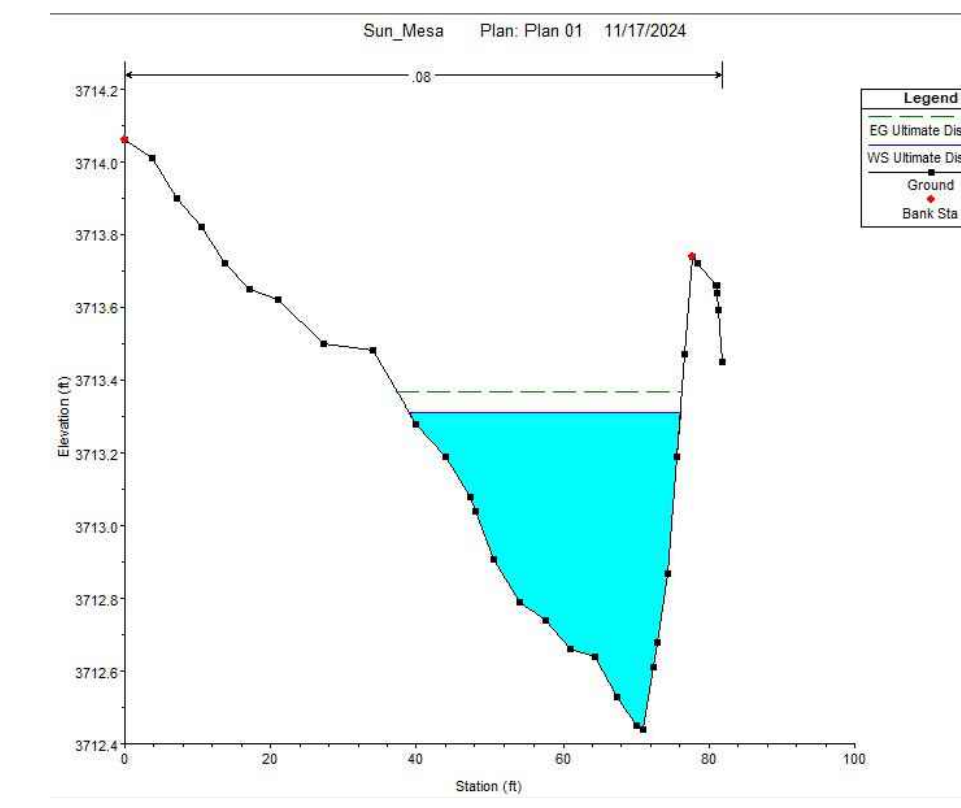

## X-SECTION: 196

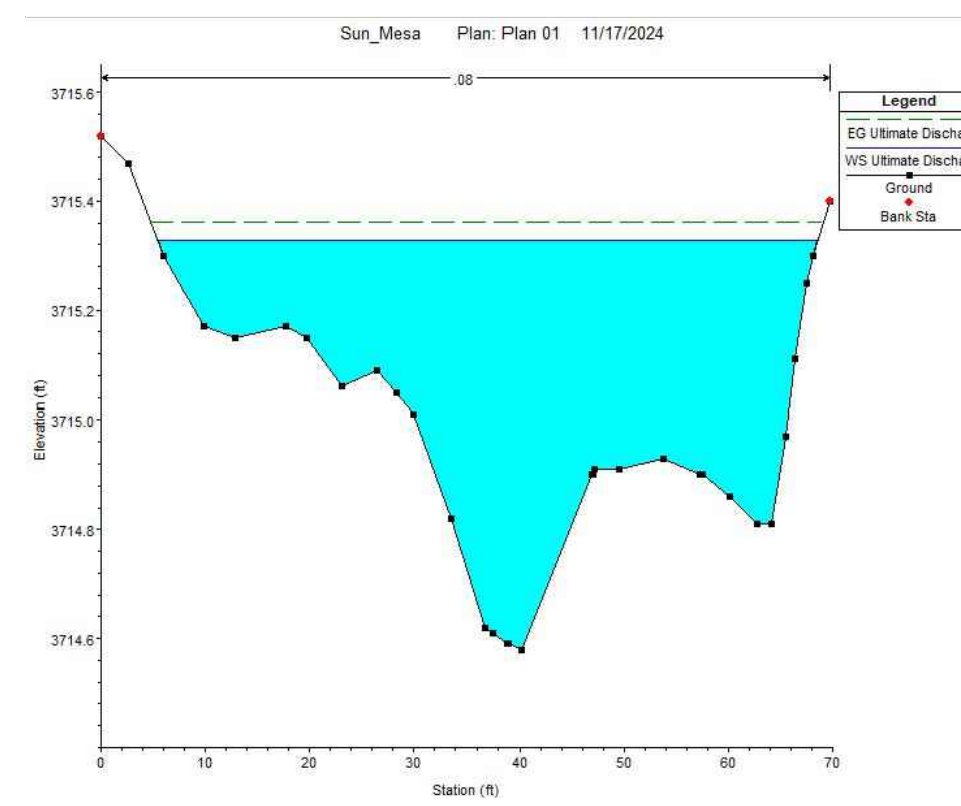

## X-SECTION: 246

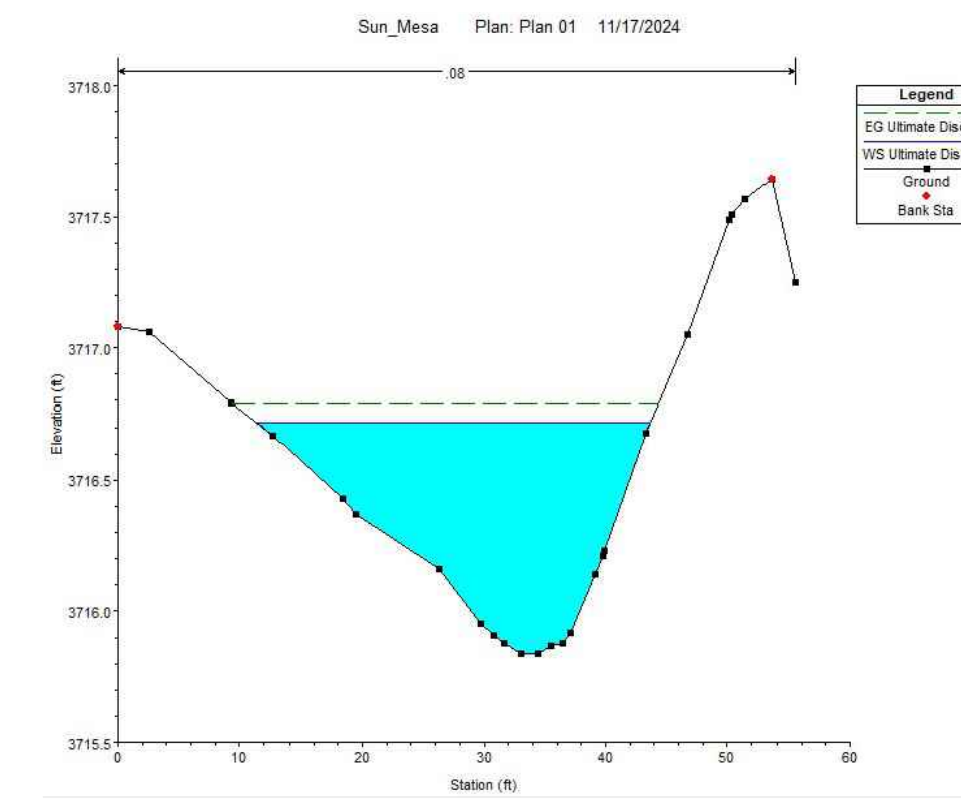

## X-SECTION: 291

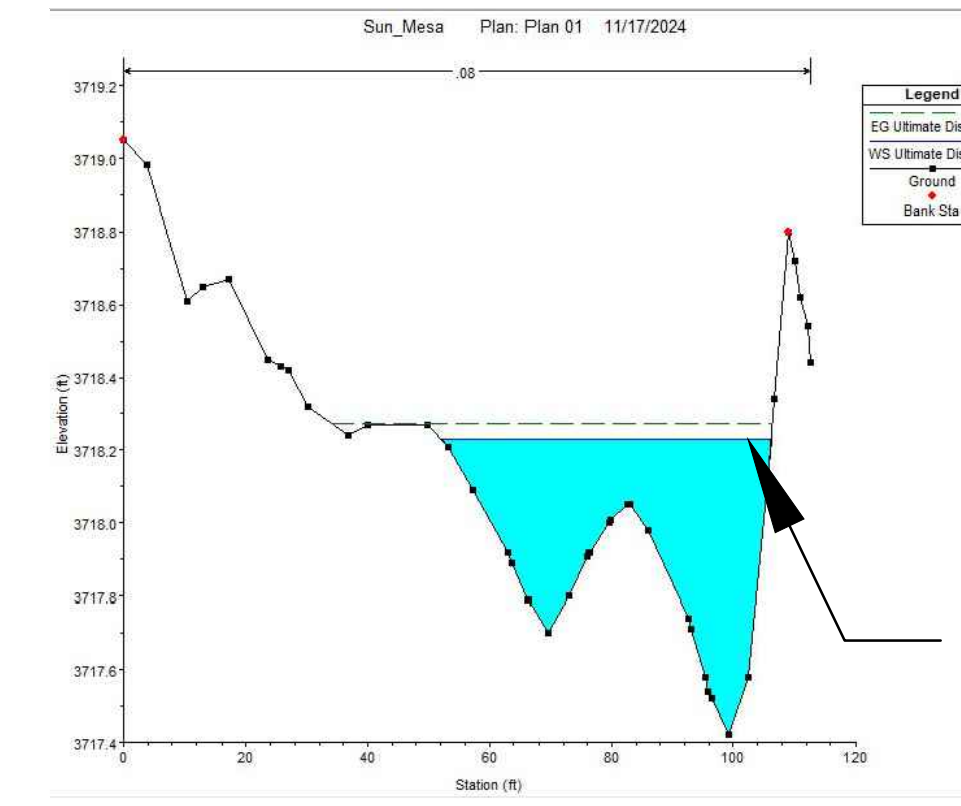

MAX WSE= 3718.23'  
DURING 100-YR STORM  
EVENT

## HEC-RAS SUMMARY RESULTS

HEC-RAS Plan: Plan 01 River: River 2 Reach: Reach 2 Profile: Ultimate Dischar												
Reach	River Sta	Profile	Q Total (cfs)	Min Ch El (ft)	W.S. Elev (ft)	Crit W.S. (ft)	E.G. Elev (ft)	E.G. Slope (ft/ft)	Vel Chnl (ft/s)	Flow Area (sq ft)	Top Width (ft)	Froude # CH
Reach 2	291	Ultimate Dischar	33.40	3717.42	3718.23		3718.27	0.030731	1.67	19.96	54.12	0.49
Reach 2	246	Ultimate Dischar	33.40	3715.84	3716.72		3716.79	0.035430	2.15	15.55	32.24	0.55
Reach 2	196	Ultimate Dischar	33.40	3714.58	3715.33		3715.36	0.023217	1.45	23.09	63.10	0.42
Reach 2	120	Ultimate Dischar	33.40	3712.44	3713.31		3713.37	0.028787	1.91	17.51	37.08	0.49
Reach 2	71	Ultimate Dischar	33.40	3711.39	3712.16		3712.19	0.019906	1.48	22.56	53.05	0.40
Reach 2	9	Ultimate Dischar	33.40	3709.94	3710.83	3710.65	3710.87	0.022810	1.52	22.01	55.19	0.42

**PREPARE BY:**  
DRP ENTERPRISES LLC  
Daniel Patneude  
MAILING ADDRESS:  
PO Box 4428  
Palm Springs, CA 92263  
206-734-7765  
Joanne C. Singer RCE 26900  
760-625-7426



# EXHIBIT D

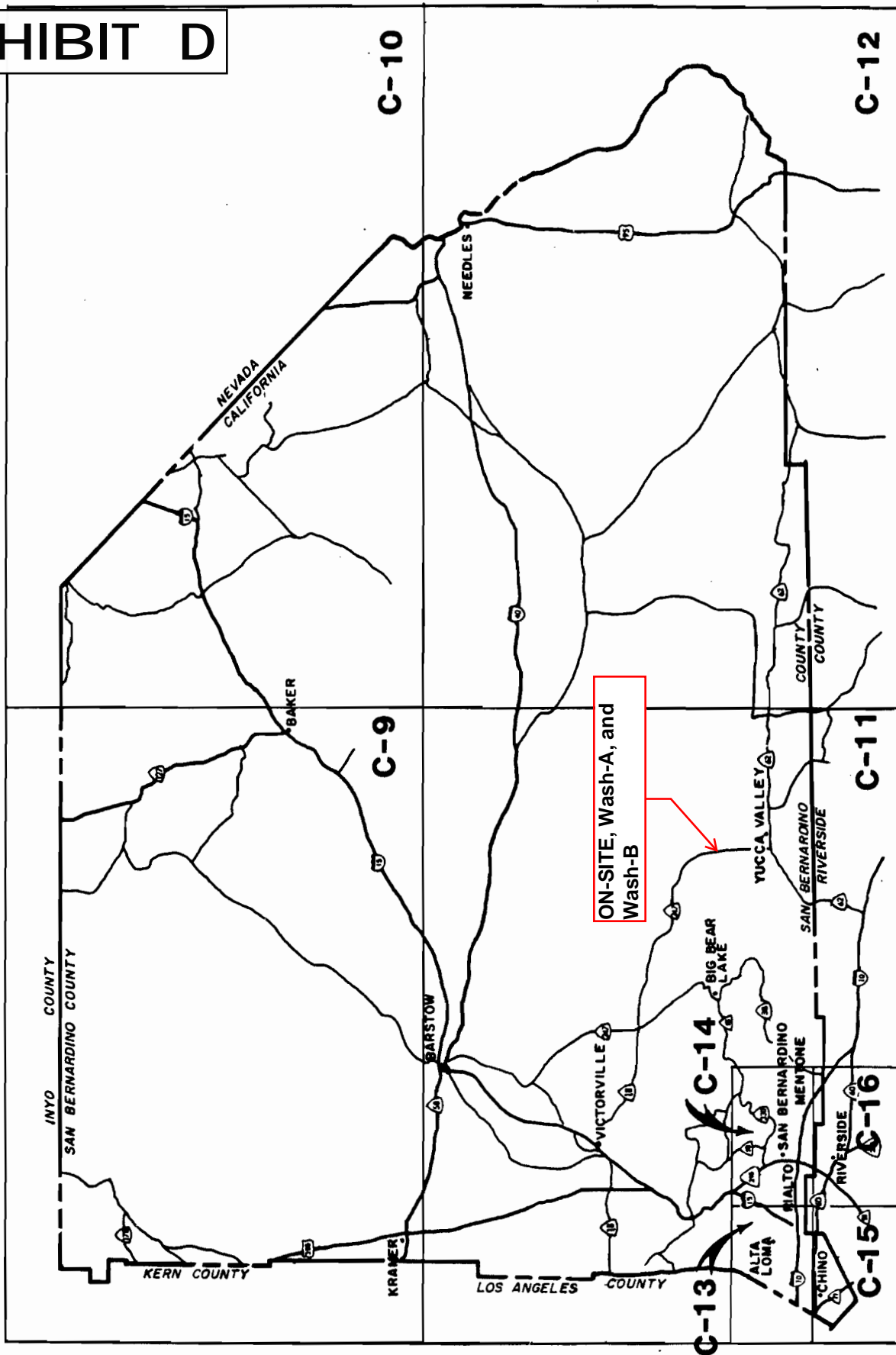

SAN BERNARDINO COUNTY  
HYDROLOGY MANUAL

SAN BERNARDINO COUNTY  
SOIL MAP INDEX

# EXHIBIT E

## HYDROLOGIC SOILS GROUP MAP FOR SOUTHCENTRAL AREA

C-24

FIGURE C-11

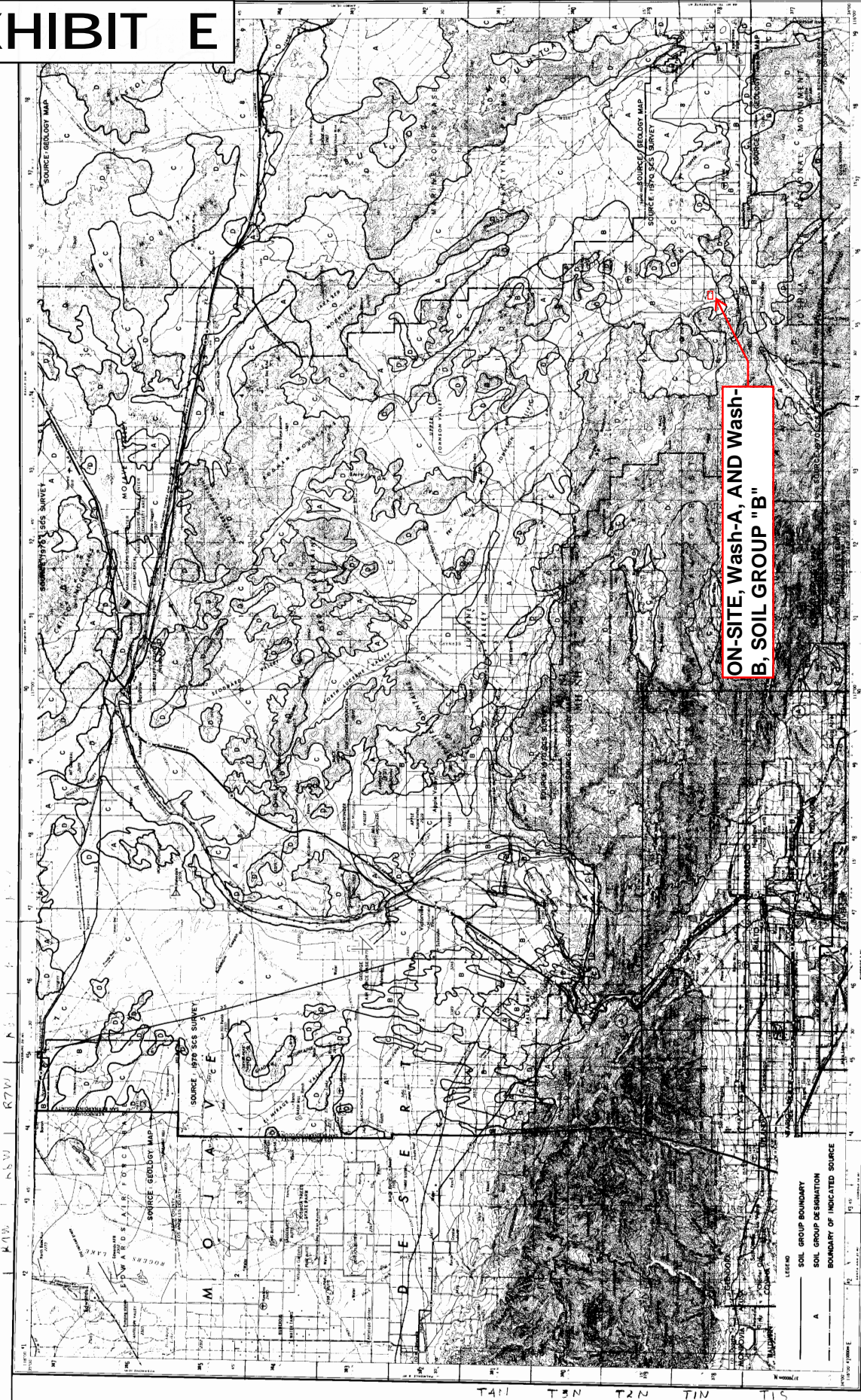

**ON-SITE, Wash-A, AND Wash-B, SOIL GROUP "B"**

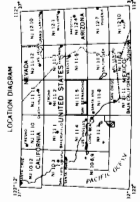

SCALE 1:250,000  
CONTOUR INTERVAL 200 FEET  
WITH SUPPLEMENTARY CONTOURS AT 100 FOOT INTERVALS  
TRANSVERSE MERCATOR PROJECTION  
MAD 8300000 1000000  
NAD 83  
BASE MAP REPRODUCED FROM U.S.G.S. "SAN BERNARDINO" TOPOGRAPHIC MAP

**SCALE REDUCED BY 1/2**

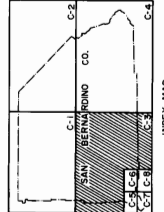

**SAN BERNARDINO COUNTY  
HYDROLOGY MANUAL**

LEGEND  
SOIL GROUP BOUNDARY  
SOIL GROUP DESIGNATION  
BOUNDARY OF INDICATED SOURCE

T411 T3N T2N TIN T1S

# EXHIBIT F

## LIMITATIONS:

1. Maximum length = 1000 Feet
2. Maximum area = 10 Acres

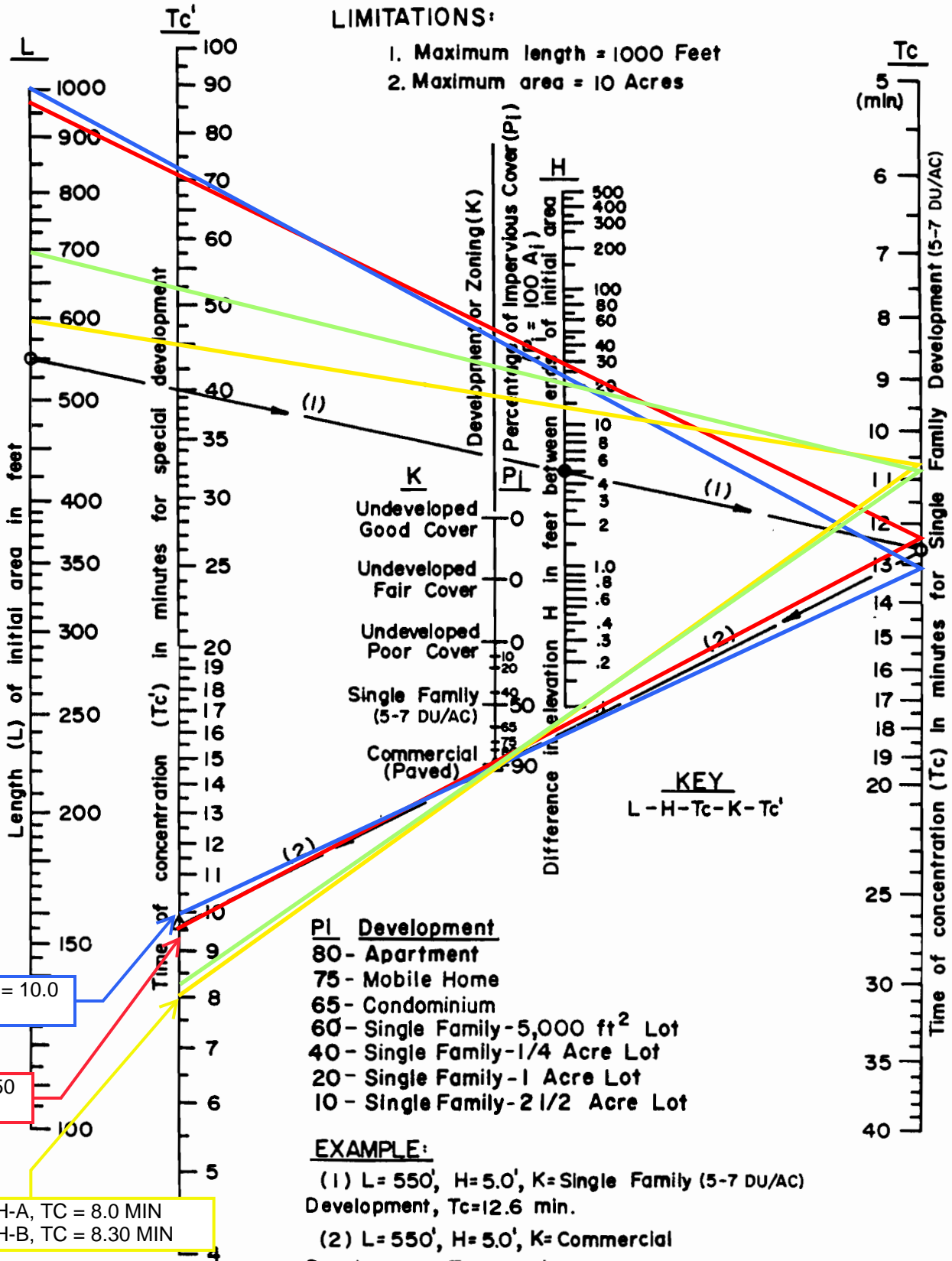

**SAN BERNARDINO COUNTY**  
HYDROLOGY MANUAL

**TIME OF CONCENTRATION**  
NOMOGRAPH  
FOR INITIAL SUBAREA

Figure D-1

# EXHIBIT G

## Curve (I) Numbers of Hydrologic Soil-Cover Complexes For Pervious Areas-AMC II

Cover Type (3)	Quality of Cover (2)	Soil Group			
		A	B	C	D
<b><u>NATURAL COVERS -</u></b>					
Barren (Rockland, eroded and graded land)		78	86	91	93
Chaparral, Broadleaf (Manzonita, ceanothus and scrub oak)	Poor	53	70	80	85
	Fair	40	63	75	81
	Good	31	57	71	78
Chaparral, Narrowleaf (Chamise and redshank)	Poor	71	82	88	91
	Fair	55	72	81	86
Grass, Annual or Perennial	Poor	67	78	86	89
	Fair	50	69	79	84
	Good	38	61	74	80
Meadows or Cienegas (Areas with seasonally high water table, principal vegetation is sod forming grass)	Poor	63	77	85	88
	Fair	51	70	80	84
	Good	30	58	71	78
Open Brush (Soft wood shrubs - buckwheat, sage, etc.)	Poor	62	76	84	88
	Fair	46	66	77	83
	Good	41	63	75	81
Woodland (Coniferous or broadleaf trees predominate. Canopy density is at least 50 percent.)	Poor	45	66	77	83
	Fair	36	60	73	79
	Good	25	55	70	77
Woodland, Grass (Coniferous or broadleaf trees with canopy density from 20 to 50 percent)	Poor	57	73	82	86
	Fair	44	65	77	82
	Good	33	58	72	79
<b><u>URBAN COVERS -</u></b>					
Residential or Commercial Landscaping (Lawn, shrubs, etc.)	Good	32	56	69	75
Turf (Irrigated and mowed grass)	Poor	58	74	83	87
	Fair	44	65	77	82
	Good	33	58	72	79
<b><u>AGRICULTURAL COVERS -</u></b>					
Fallow (Land plowed but not tilled or seeded)		77	86	91	94

EXISTING CONDITION ON-SITE, OFF-SITE WASH A AND -B

**SAN BERNARDINO COUNTY**  
**HYDROLOGY MANUAL**

**CURVE NUMBERS**  
**FOR**  
**PERVIOUS AREAS**

# EXHIBIT H

## Curve (I) Numbers of Hydrologic Soil-Cover Complexes For Pervious Areas-AMC II

Cover Type (3)	Quality of Cover (2)	Soil Group			
		A	B	C	D
<b>AGRICULTURAL COVERS (Continued)</b>					
Legumes, Close Seeded (Alfalfa, sweetclover, timothy, etc.)	Poor	66	77	85	89
	Good	58	72	81	85
Orchards, Evergreen (Citrus, avocados, etc.)	Poor	57	73	82	86
	Fair	44	65	77	82
	Good	33	58	72	79
Pasture, Dryland (Annual grasses)	Poor	68	79	86	89
	Fair	49	69	79	84
	Good	39	61	74	80
Pasture, Irrigated (Legumes and perennial grass)	Poor	58	74	83	87
	Fair	44	65	77	82
	Good	33	58	72	79
Row Crops (Field crops - tomatoes, sugar beets, etc.)	Poor	72	81	88	91
	Good	67	78	85	89
Small grain (Wheat, oats, barley, etc.)	Poor	65	76	84	88
	Good	63	75	83	87

**Notes:**

- All curve numbers are for Antecedent Moisture Condition (AMC) II.
- Quality of cover definitions:  
 Poor-Heavily grazed, regularly burned areas, or areas of high burn potential. Less than 50 percent of the ground surface is protected by plant cover or brush and tree canopy.  
 Fair-Moderate cover with 50 percent to 75 percent of the ground surface protected.  
 Good-Heavy or dense cover with more than 75 percent of the ground surface protected.
- See Figure C-2 for definition of cover types.

**SAN BERNARDINO COUNTY**  
**HYDROLOGY MANUAL**

**CURVE NUMBERS**  
**FOR**  
**PERVIOUS AREAS**

# EXHIBIT I

## ACTUAL IMPERVIOUS COVER

Land Use (1)	Range-Percent	Recommended Value For Average Conditions-Percent (2)
Natural or Agriculture	0 - 0	0
Public Park	10 - 25	15
School	30 - 50	40
Single Family Residential: (3)		
2.5 acre lots	5 - 15	10
1 acre lots	10 - 25	20
2 dwellings/acre	20 - 40	30
3-4 dwellings/acre	30 - 50	40
5-7 dwellings/acre	35 - 55	50
8-10 dwellings/acre	50 - 70	60
More than 10 dwellings/acre	65 - 90	80
Multiple Family Residential:		
Condominiums	45 - 70	65
Apartments	65 - 90	80
Mobile Home Park	60 - 85	75
Commercial, Downtown Business or Industrial	80 - 100	90

**Notes:**

**Site Impervious Cover**

1. Land use should be based on ultimate development of the watershed. Long range master plans for the County and incorporated cities should be reviewed to insure reasonable land use assumptions.
2. Recommended values are based on average conditions which may not apply to a particular study area. The percentage impervious may vary greatly even on comparable sized lots due to differences in dwelling size, improvements, etc. Landscape practices should also be considered as it is common in some areas to use ornamental gravels underlain by impervious plastic materials in place of lawns and shrubs. A field investigation of a study area shall always be made, and a review of aerial photos, where available, may assist in estimating the percentage of impervious cover in developed areas.
3. For typical equestrian subdivisions increase impervious area 5 percent over the values recommended in the table above.

**SAN BERNARDINO COUNTY  
HYDROLOGY MANUAL**

**ACTUAL IMPERVIOUS COVER  
FOR  
DEVELOPED AREAS**

# EXHIBIT J

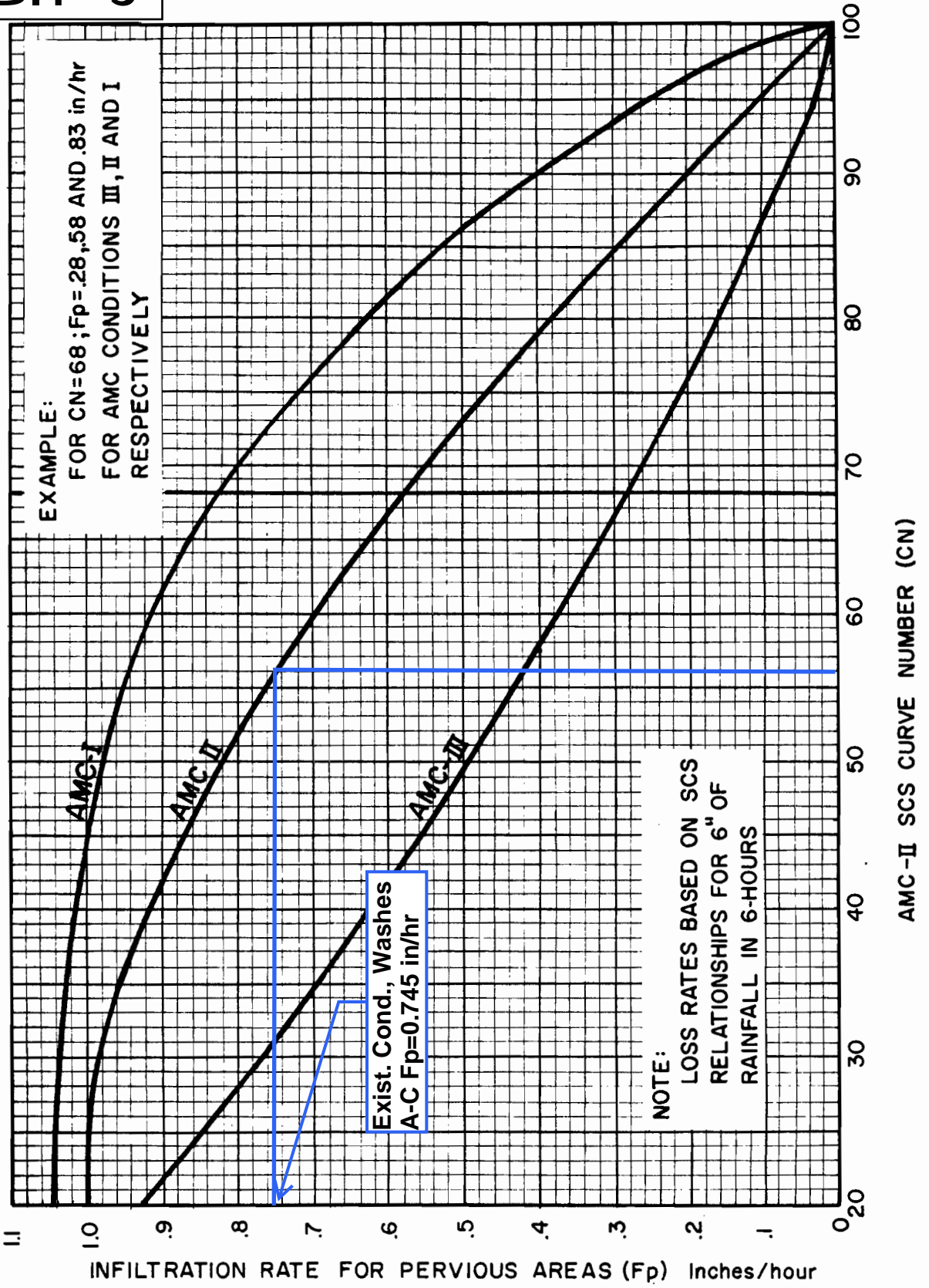

**SAN BERNARDINO COUNTY  
HYDROLOGY MANUAL**

**INFILTRATION RATE FOR  
PERVIOUS AREAS VERSUS  
SCS CURVE NUMBERS**

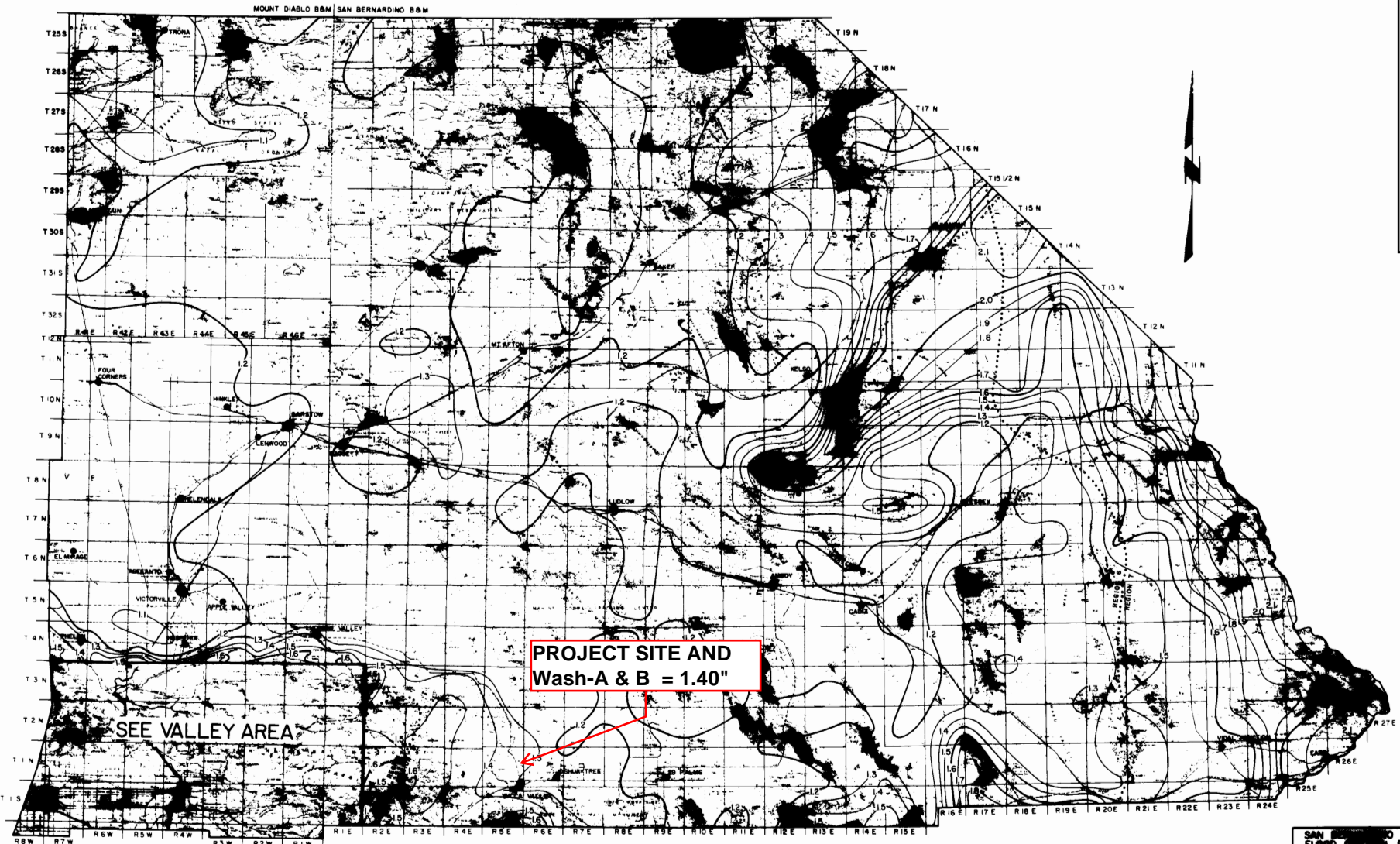

**SAN BERNARDINO COUNTY**  
**HYDROLOGY MANUAL**

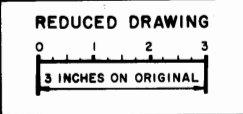

LEGEND:  
 2 ISOLINES PRECIPITATION (INCHES)

SAN BERNARDINO COUNTY  
 FLOOD CONTROL DISTRICT

**DESERT AREA**  
 METEOLS  
 Y<sub>100</sub>-100 YEAR 1 HOUR  
 BASED ON USBC, NOAA ATLAS 2, 1973

APPROVED BY:

DATE: 1982  
 SHEET: 1 OF 1

# EXHIBIT L

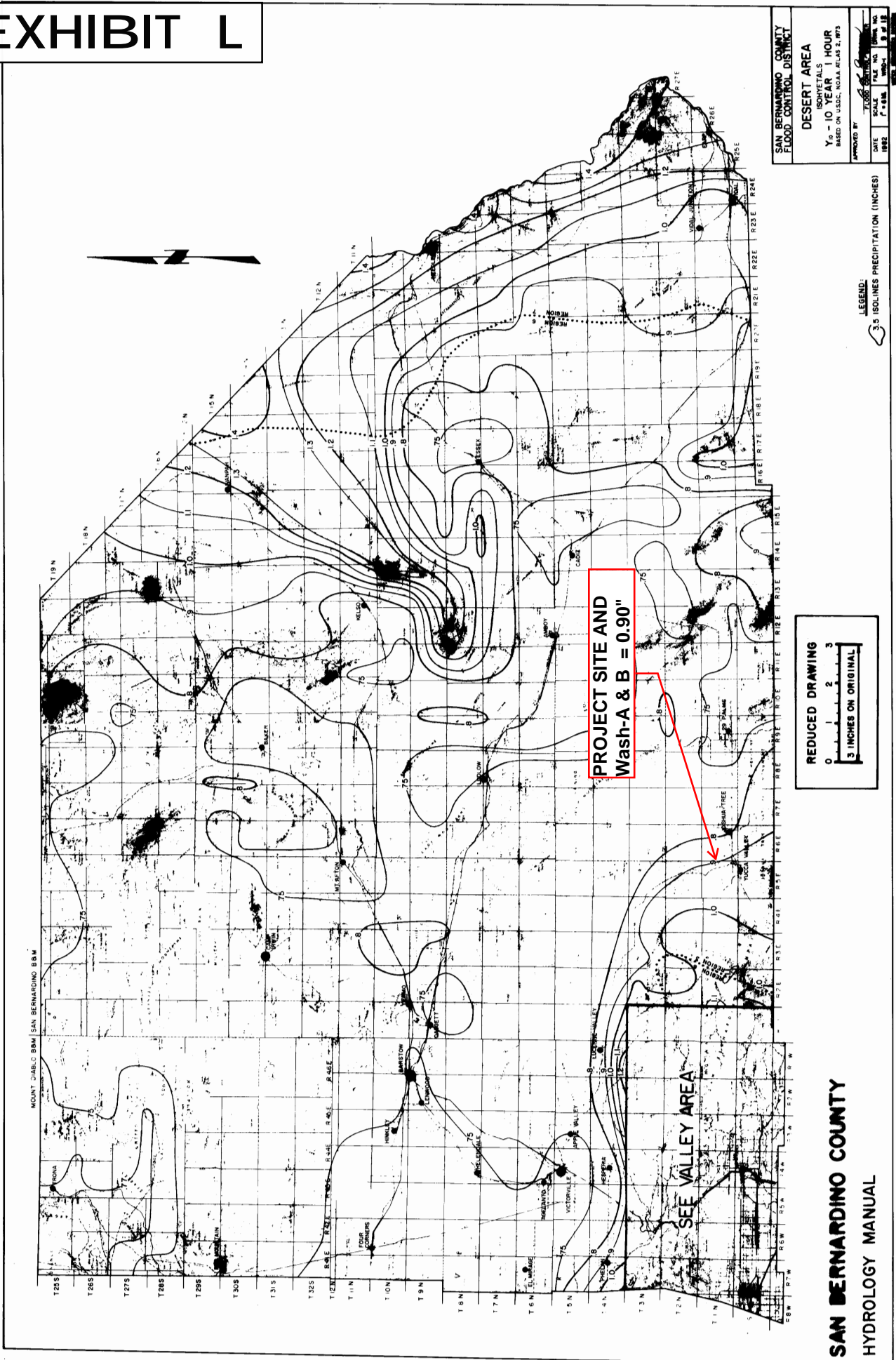

**SAN BERNARDINO COUNTY**  
HYDROLOGY MANUAL

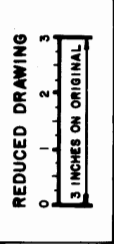

LEGEND:  
3.5 ISOLINES PRECIPITATION (INCHES)

SAN BERNARDINO COUNTY  
FLOOD CONTROL DISTRICT  
**DESERT AREA**  
ISOHYETALS  
Y<sub>5</sub> - 10 YEAR 1 HOUR  
BASED ON U.S.D.C. NOAA ATLAS 2, 1973  
APPROVED BY: [Signature]  
DATE: [Blank] SCALE: [Blank] SHEET NO.: [Blank] OF [Blank]  
PROJECT NO.: [Blank]

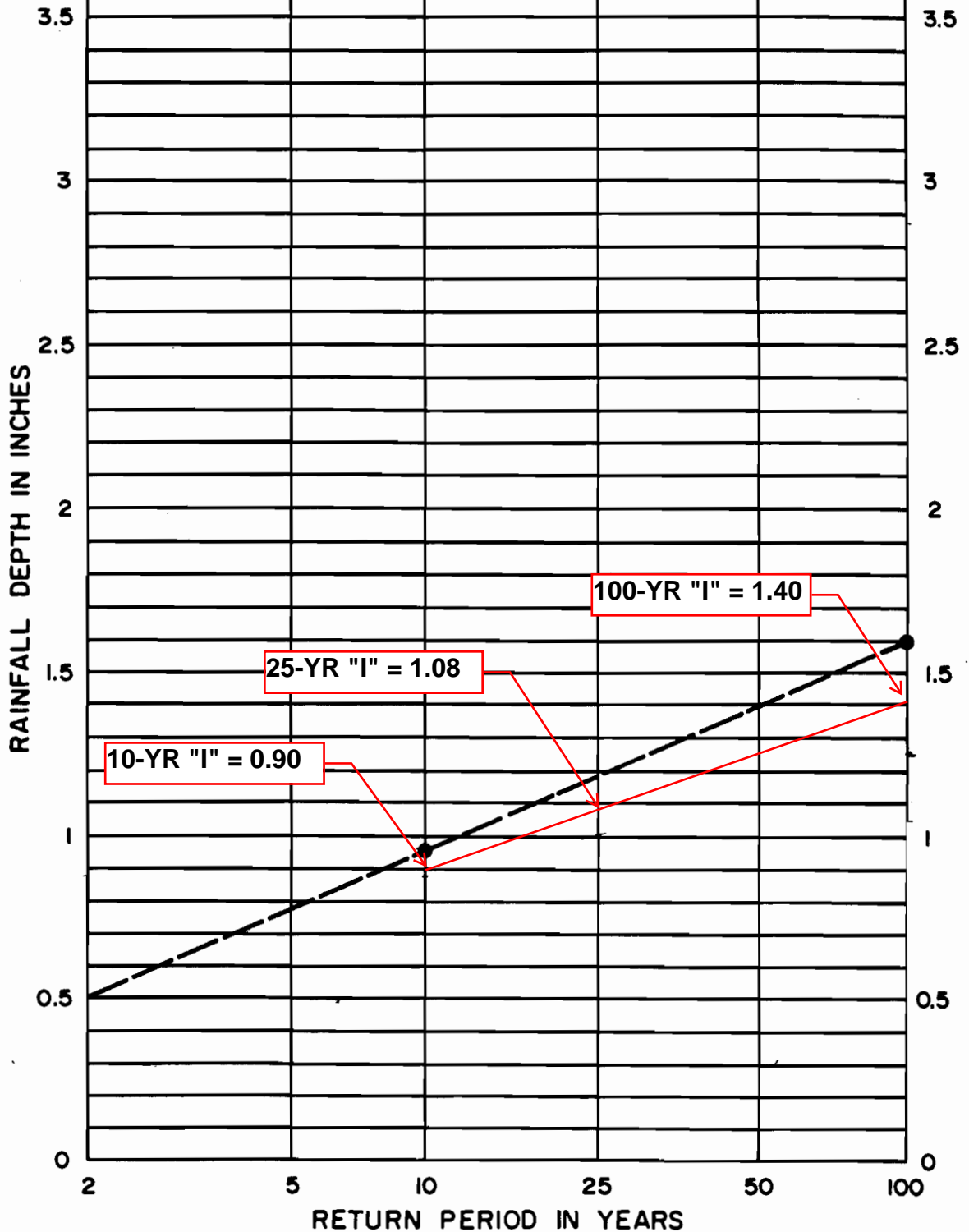

**NOTE:**  
 1. FOR INTERMEDIATE RETURN PERIODS PLOT 10-YEAR AND 100-YEAR ONE HOUR VALUES FROM MAPS, THEN CONNECT POINTS AND READ VALUE FOR DESIRED RETURN PERIOD. FOR EXAMPLE GIVEN 10-YEAR ONE HOUR = 0.95" AND 100-YEAR ONE HOUR = 1.60", 25-YEAR ONE HOUR = 1.18".

REFERENCE: NOAA ATLAS 2, VOLUME XI - CAL., 1973

**SAN BERNARDINO COUNTY**  
 HYDROLOGY MANUAL

**RAINFALL DEPTH VERSUS**  
**RETURN PERIOD FOR**  
**PARTIAL DURATION SERIES**

# EXHIBIT N

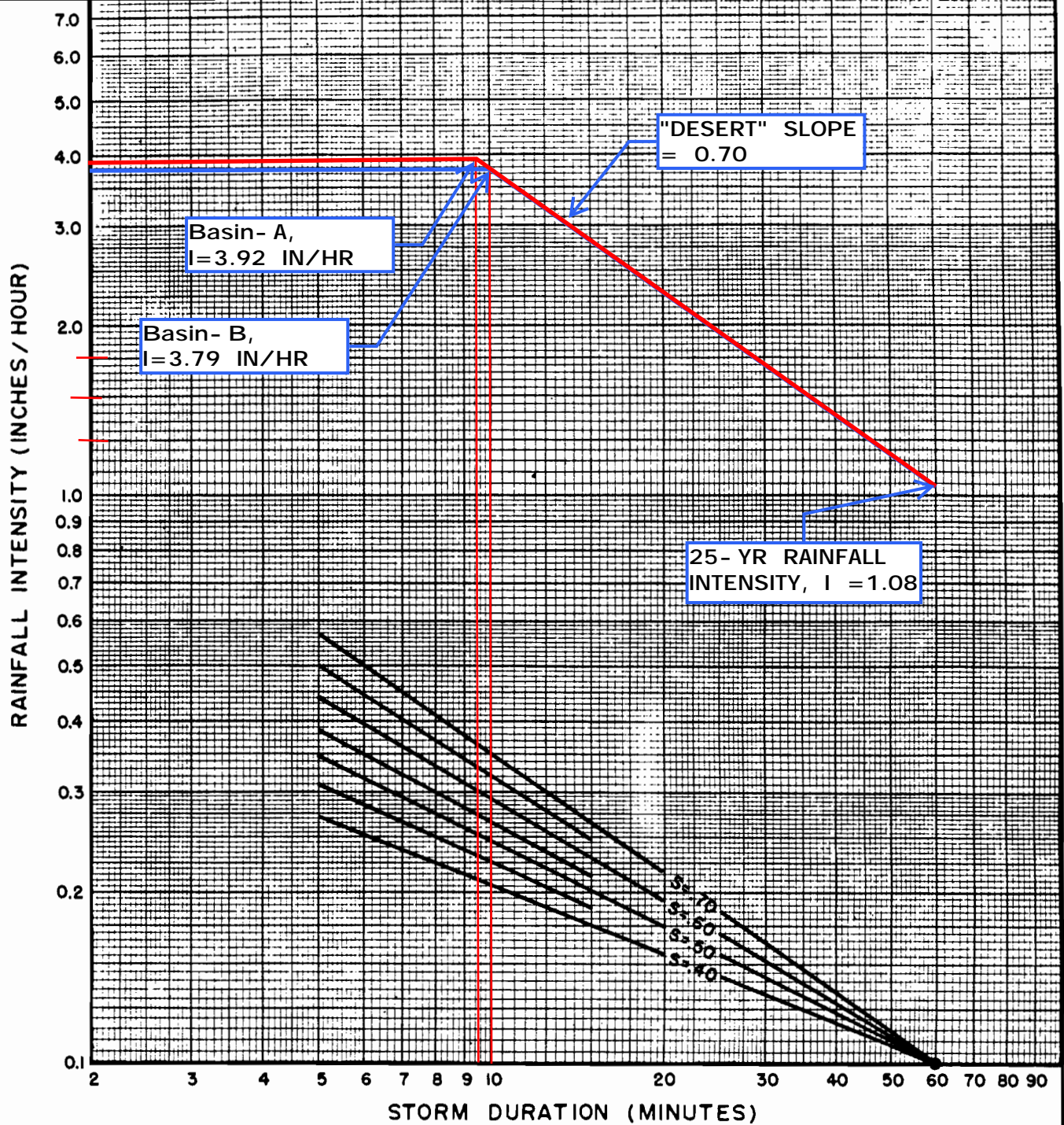

DESIGN STORM FREQUENCY = 100 YEARS  
 ONE HOUR POINT RAINFALL = 1.40 INCHES  
 LOG-LOG SLOPE = 0.70  
 PROJECT LOCATION = South Central

25-Year  
 1.08 INCHES

**SAN BERNARDINO COUNTY**  
 HYDROLOGY MANUAL

**INTENSITY - DURATION  
 CURVES  
 CALCULATION SHEET**

# National Flood Hazard Layer FIRMette

























# EXHIBIT 0

116°25'34"W 34°10'16"N



## Legend

SEE FIS REPORT FOR DETAILED LEGEND AND INDEX MAP FOR FIRM PANEL LAYOUT

- |   |  |  |
|---|--|--|
| <b>SPECIAL FLOOD HAZARD AREAS</b>   |   | Without Base Flood Elevation (BFE)<br><i>Zone A, V, A99</i>  |
|   |   | With BFE or Depth <i>Zone AE, AO, AH, VE, AR</i><br>Regulatory Floodway  |
| <b>OTHER AREAS OF FLOOD HAZARD</b>  |   | 0.2% Annual Chance Flood Hazard, Areas of 1% annual chance flood with average depth less than one foot or with drainage areas of less than one square mile <i>Zone X</i> |
|   |   | Future Conditions 1% Annual Chance Flood Hazard <i>Zone X</i>  |
|   |   | Area with Reduced Flood Risk due to Levee. See Notes. <i>Zone X</i>  |
|   |   | Area with Flood Risk due to Levee <i>Zone D</i>  |
| <b>OTHER AREAS</b>  |   | NO SCREEN Area of Minimal Flood Hazard <i>Zone X</i>   |
|   |   | Effective LOMRs  |
| <b>GENERAL STRUCTURES</b>   |   | Area of Undetermined Flood Hazard <i>Zone D</i>  |
|   |   | Channel, Culvert, or Storm Sewer   |
| <b>OTHER FEATURES</b>   |   | Levee, Dike, or Floodwall  |
|   |   | 20.2 Cross Sections with 1% Annual Chance Water Surface Elevation  |
| <b>MAP PANELS</b>   |   | 17.5 Coastal Transect  |
|   |   | Base Flood Elevation Line (BFE)  |
|   |   | Limit of Study   |
|   |   | Jurisdiction Boundary  |
|   |   | Coastal Transect Baseline  |
|   |   | Profile Baseline   |
| <b>MAP PANELS</b>   |    | Digital Data Available   |
|   |   | No Digital Data Available  |
|   |   | Unmapped   |
|  | The pin displayed on the map is an approximate point selected by the user and does not represent an authoritative property location. |  |

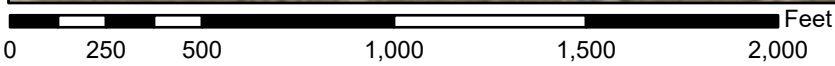

1:6,000

116°24'57"W 34°9'46"N

Basemap Imagery Source: USGS National Map 2023

This map complies with FEMA's standards for the use of digital flood maps if it is not void as described below. The basemap shown complies with FEMA's basemap accuracy standards

The flood hazard information is derived directly from the authoritative NFHL web services provided by FEMA. This map was exported on **11/13/2024 at 1:53 PM** and does not reflect changes or amendments subsequent to this date and time. The NFHL and effective information may change or become superseded by new data over time.

This map image is void if the one or more of the following map elements do not appear: basemap imagery, flood zone labels, legend, scale bar, map creation date, community identifiers, FIRM panel number, and FIRM effective date. Map images for unmapped and unmodernized areas cannot be used for regulatory purposes.

# EXHIBIT Q



**NOAA Atlas 14, Volume 6, Version 2**  
**Location name: Yucca Valley, California, USA\***  
**Latitude: 34.1669°, Longitude: -116.421°**  
**Elevation: 3721 ft\*\***  
 \* source: ESRI Maps  
 \*\* source: USGS



## POINT PRECIPITATION FREQUENCY ESTIMATES

Sanja Perica, Sarah Dietz, Sarah Heim, Lillian Hiner, Kazungu Maitaria, Deborah Martin, Sandra Pavlovic, Ishani Roy, Carl Trypaluk, Dale Unruh, Fenglin Yan, Michael Yekta, Tan Zhao, Geoffrey Bonnin, Daniel Brewer, Li-Chuan Chen, Tye Parzybok, John Yarchoan

NOAA, National Weather Service, Silver Spring, Maryland

[PF\\_tabular](#) | [PF\\_graphical](#) | [Maps\\_&\\_aerials](#)

### PF tabular

PDS-based point precipitation frequency estimates with 90% confidence intervals (in inches) <sup>1</sup>										
Duration	Average recurrence interval (years)									
	1	2	5	10	25	50	100	200	500	1000
5-min	0.088 (0.073-0.107)	0.129 (0.107-0.158)	0.191 (0.157-0.234)	0.247 (0.202-0.306)	0.335 (0.265-0.428)	0.412 (0.319-0.537)	0.500 (0.378-0.667)	0.601 (0.442-0.825)	0.758 (0.535-1.08)	1.01 (0.690-1.50)
10-min	0.126 (0.104-0.154)	0.185 (0.153-0.226)	0.274 (0.225-0.335)	0.355 (0.290-0.438)	0.480 (0.380-0.613)	0.590 (0.458-0.770)	0.716 (0.541-0.956)	0.861 (0.634-1.18)	1.09 (0.767-1.56)	1.45 (0.990-2.15)
15-min	0.152 (0.126-0.186)	0.224 (0.185-0.274)	0.331 (0.273-0.405)	0.429 (0.351-0.530)	0.581 (0.459-0.742)	0.714 (0.553-0.931)	0.866 (0.655-1.16)	1.04 (0.766-1.43)	1.31 (0.928-1.88)	1.75 (1.20-2.60)
30-min	0.231 (0.192-0.283)	0.341 (0.282-0.416)	0.503 (0.415-0.617)	0.652 (0.533-0.806)	0.884 (0.699-1.13)	1.09 (0.842-1.42)	1.32 (0.996-1.76)	1.58 (1.17-2.18)	2.00 (1.41-2.86)	2.67 (1.82-3.95)
60-min	0.322 (0.267-0.393)	0.474 (0.392-0.580)	0.701 (0.578-0.859)	0.908 (0.743-1.12)	1.23 (0.973-1.57)	1.51 (1.17-1.97)	1.83 (1.39-2.45)	2.21 (1.62-3.03)	2.78 (1.96-3.98)	3.72 (2.54-5.50)
2-hr	0.447 (0.370-0.545)	0.630 (0.521-0.770)	0.896 (0.738-1.10)	1.13 (0.927-1.40)	1.49 (1.18-1.90)	1.80 (1.39-2.34)	2.13 (1.61-2.85)	2.51 (1.85-3.45)	3.08 (2.18-4.41)	3.75 (2.56-5.56)
3-hr	0.531 (0.440-0.649)	0.739 (0.611-0.903)	1.04 (0.854-1.27)	1.30 (1.06-1.60)	1.69 (1.34-2.16)	2.02 (1.56-2.63)	2.38 (1.80-3.18)	2.78 (2.04-3.82)	3.38 (2.38-4.83)	3.88 (2.65-5.75)
6-hr	0.698 (0.577-0.852)	0.959 (0.793-1.17)	1.33 (1.09-1.63)	1.65 (1.35-2.04)	2.12 (1.67-2.70)	2.50 (1.94-3.26)	2.92 (2.21-3.90)	3.38 (2.48-4.64)	4.04 (2.85-5.78)	4.60 (3.14-6.81)
12-hr	0.870 (0.720-1.06)	1.20 (0.994-1.47)	1.67 (1.37-2.04)	2.07 (1.69-2.56)	2.66 (2.10-3.39)	3.14 (2.43-4.09)	3.66 (2.76-4.88)	4.22 (3.11-5.80)	5.05 (3.56-7.22)	5.73 (3.91-8.49)
24-hr	1.09 (0.966-1.26)	1.53 (1.35-1.76)	2.14 (1.89-2.48)	2.68 (2.35-3.13)	3.47 (2.94-4.18)	4.12 (3.42-5.07)	4.83 (3.92-6.08)	5.61 (4.43-7.26)	6.75 (5.12-9.09)	7.71 (5.64-10.7)
2-day	1.22 (1.08-1.41)	1.74 (1.54-2.01)	2.48 (2.19-2.87)	3.13 (2.74-3.65)	4.10 (3.47-4.93)	4.90 (4.07-6.02)	5.78 (4.68-7.27)	6.75 (5.32-8.73)	8.18 (6.20-11.0)	9.39 (6.88-13.1)
3-day	1.33 (1.18-1.53)	1.92 (1.70-2.21)	2.76 (2.44-3.19)	3.50 (3.07-4.08)	4.61 (3.91-5.55)	5.54 (4.60-6.81)	6.57 (5.32-8.26)	7.70 (6.08-9.96)	9.39 (7.11-12.6)	10.8 (7.92-15.1)
4-day	1.38 (1.22-1.59)	2.01 (1.78-2.32)	2.92 (2.57-3.37)	3.72 (3.25-4.33)	4.91 (4.16-5.91)	5.92 (4.92-7.27)	7.03 (5.70-8.84)	8.26 (6.52-10.7)	10.1 (7.65-13.6)	11.7 (8.54-16.2)
7-day	1.53 (1.36-1.76)	2.26 (2.00-2.61)	3.31 (2.92-3.82)	4.24 (3.71-4.94)	5.63 (4.77-6.78)	6.81 (5.65-8.37)	8.11 (6.57-10.2)	9.56 (7.54-12.4)	11.7 (8.88-15.8)	13.6 (9.94-18.9)
10-day	1.64 (1.45-1.89)	2.43 (2.15-2.81)	3.58 (3.16-4.13)	4.59 (4.02-5.35)	6.10 (5.18-7.35)	7.39 (6.14-9.08)	8.80 (7.14-11.1)	10.4 (8.19-13.4)	12.7 (9.65-17.2)	14.7 (10.8-20.5)
20-day	1.84 (1.63-2.12)	2.74 (2.43-3.16)	4.03 (3.56-4.66)	5.17 (4.53-6.02)	6.86 (5.82-8.26)	8.28 (6.88-10.2)	9.85 (7.98-12.4)	11.6 (9.14-15.0)	14.2 (10.7-19.1)	16.4 (12.0-22.8)
30-day	2.06 (1.82-2.37)	3.07 (2.72-3.54)	4.51 (3.98-5.21)	5.77 (5.05-6.72)	7.63 (6.47-9.19)	9.20 (7.64-11.3)	10.9 (8.84-13.7)	12.8 (10.1-16.6)	15.6 (11.8-21.0)	18.0 (13.2-25.1)
45-day	2.40 (2.12-2.76)	3.55 (3.14-4.09)	5.16 (4.55-5.96)	6.57 (5.75-7.66)	8.63 (7.32-10.4)	10.3 (8.59-12.7)	12.2 (9.91-15.4)	14.3 (11.3-18.5)	17.3 (13.1-23.4)	19.9 (14.6-27.8)
60-day	2.72 (2.42-3.14)	4.00 (3.54-4.61)	5.78 (5.10-6.68)	7.32 (6.41-8.53)	9.57 (8.11-11.5)	11.4 (9.49-14.0)	13.4 (10.9-16.9)	15.7 (12.4-20.3)	18.9 (14.3-25.5)	21.7 (15.9-30.2)

<sup>1</sup> Precipitation frequency (PF) estimates in this table are based on frequency analysis of partial duration series (PDS). Numbers in parenthesis are PF estimates at lower and upper bounds of the 90% confidence interval. The probability that precipitation frequency estimates (for a given duration and average recurrence interval) will be greater than the upper bound (or less than the lower bound) is 5%. Estimates at upper bounds are not checked against probable maximum precipitation (PMP) estimates and may be higher than currently valid PMP values. Please refer to NOAA Atlas 14 document for more information.

[Back to Top](#)

### PF graphical

PDS-based depth-duration-frequency (DDF) curves

Latitude: 34.1669°, Longitude: -116.4210°

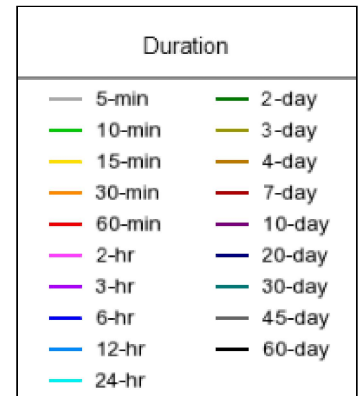
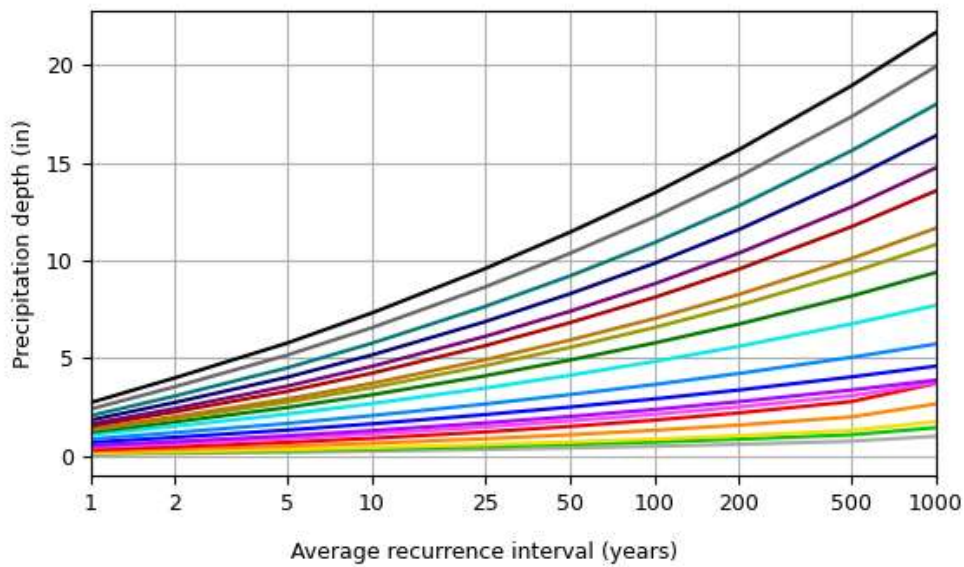
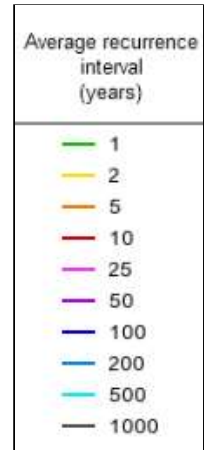
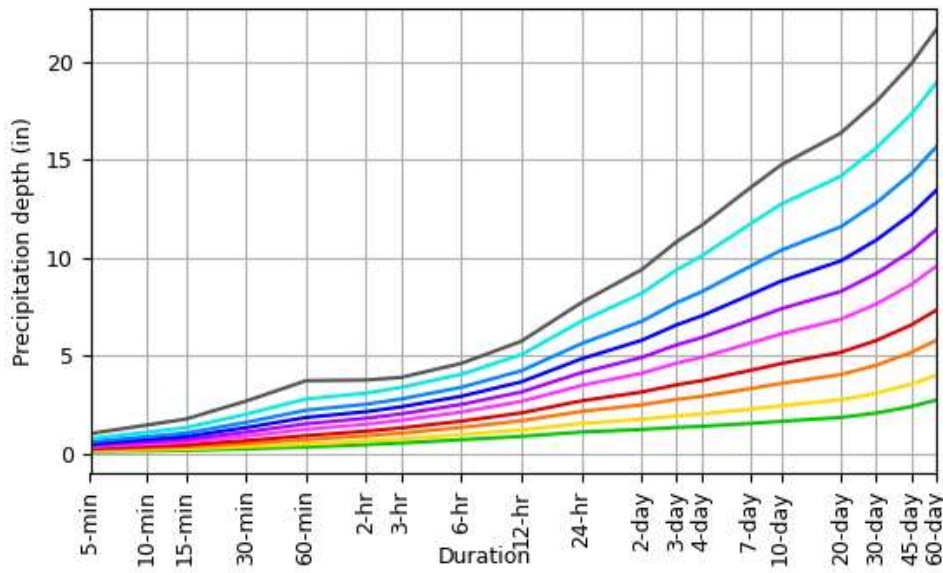

[Back to Top](#)

**Maps & aeriels**

**Small scale terrain**

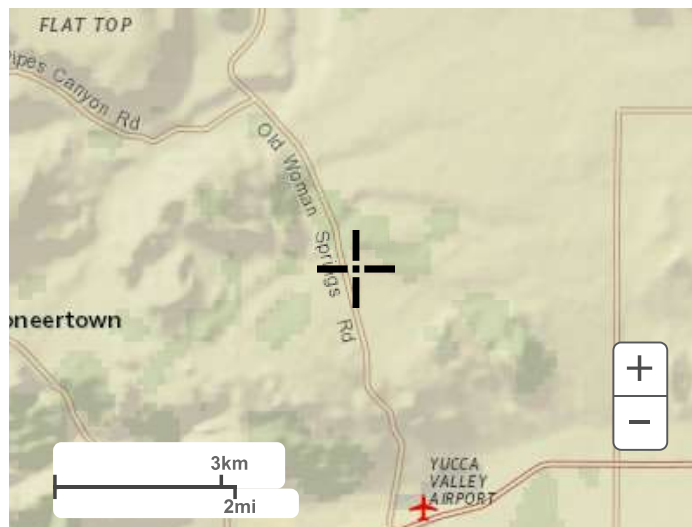

Large scale terrain



Large scale map



Large scale aerial

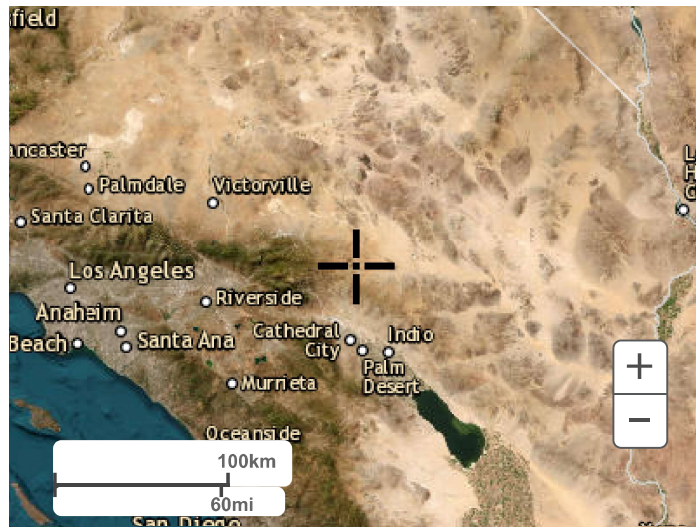

[Back to Top](#)

---

[US Department of Commerce](#)  
[National Oceanic and Atmospheric Administration](#)  
[National Weather Service](#)  
[National Water Center](#)  
1325 East West Highway  
Silver Spring, MD 20910  
Questions?: [HDSC.Questions@noaa.gov](mailto:HDSC.Questions@noaa.gov)

[Disclaimer](#)